

Architectural Precast Concrete Walls

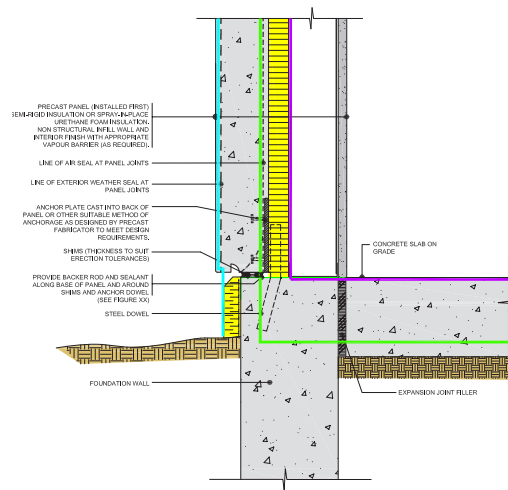

1 SINGLE WYTHE PRECAST PANEL BOTTOM BEARING & LATERAL FOUNDATION WALL CONNECTION



Best Practice Guide

ARCHITECTURAL PRECAST CONCRETE WALLS

Best Practice Guide



**Canadian Precast/Prestressed
Concrete Institute**

PO Box 24058 Hazeldean
Ottawa, ON, Canada K2M 2C3

Tel: (613) 232-2619
Email: info@cpci.ca
Web: www.cpci.ca



**A Division of 2174863
Ontario Limited**

44 Cityview Circle
Barrie, Ontario L4N 7V2

Tel: (647) 861-5348
Email: malcolm.meh@gmail.com

Copyright 2017

by

Canadian Precast/Prestressed Concrete Institute

www.cpci.ca

All rights reserved. This book or any part thereof must not be reproduced in any form without the written permission of the Canadian Precast/Prestressed Concrete Institute.

Disclaimer: This Guide is not intended to replace professional expertise. When the information contained within this Best Practice Guide is used as guidance and incorporated into the design of buildings, it must be reviewed by knowledgeable engineering and building envelope professionals and reflect the specific and potentially unique conditions and design parameters of each building. Readers are advised to evaluate the information, materials and techniques cautiously for themselves and to consult appropriate professional resources to determine whether information, materials and techniques are suitable for their application. The drawings and text are intended as general best practice guidelines only. The project and site specific factors of climate, cost, aesthetics, and so on must be taken into consideration. Use of the Guide does not relieve designers of their responsibility to comply with local building codes, standards and bylaws with respect to the design and construction of the building envelope.

Contents

CHAPTER 1 Introduction	1-1
1.1 Context / Background.....	1-1
1.2 The Purpose of this Best Practice Guide	1-2
1.2.1 The Canadian Precast/Prestressed Concrete Institute.....	1-2
1.2.2 Other Related Building Science Publications	1-3
1.3 Technical Review	1-3
Members of the technical committee of CPCI (2017):.....	1-3
CHAPTER 2 Architectural Precast Concrete Wall Panels Defined	2-1
2.1 Panel Types	2-1
2.1.1 Single Wythe Precast Concrete Wall Panels	2-1
2.1.2 Double Wythe Precast Concrete Insulated Wall Panels.....	2-2
2.2 Other Panel Configurations.....	2-5
2.2.1 Drained Assemblies – Single and Double Wythe Insulated Precast Concrete Wall Assemblies with ‘rain screen’ drainage layer – Not recommended but discussed	2-5
2.2.2 Thin Veneer Single Wythe Wall Assembly.....	2-6
2.3 Wall Panel Layout (and its effect on joints).....	2-6
2.3.1 Categories of Precast Panel Layout	2-7
2.3.1.1 Horizontal Precast Spandrels with Vertical Column Covers	2-8
2.3.1.2 Alternate Bands of Precast Spandrels and Glazing	2-8
2.3.1.3 Punched Windows	2-8
2.3.1.4 Solid Wall Panels.....	2-8
2.3.2 Double wythe insulated wall panel sizes	2-11
2.4 Colours, Finishes, and Veneers.....	2-12
2.4.1 Colour.....	2-13
2.4.2 Textures and Finishes	2-14
2.4.2.1 Smooth as Cast	2-15
2.4.2.2 Exposed Aggregate	2-16
2.4.2.3 Abrasive Blast (Sandblast) Finish	2-16
2.4.2.4 Acid Etching	2-17
2.4.2.5 Bush Hammered Finish.....	2-17
2.4.2.6 Sand Embedment.....	2-17
2.4.3 Stone Veneered Precast Panels.....	2-17
2.4.4 Clay Product Faced Precast (Brick, Tile and Terra Cotta).....	2-18
2.4.5 Form Liners	2-20
CHAPTER 3 Manufacturing, Transportation and Installation	3-1
3.1 Manufacturing, Materials and Quality Control.....	3-1
3.1.1 Precast Concrete Panel Manufacturing	3-1
3.1.2 Form Configurations	3-1
3.1.3 Materials.....	3-3
3.1.4 Precast Concrete Panel Manufacturer Certification	3-3
3.2 Transportation and Installation.....	3-4
3.2.1 Precast Panel Transportation from Plant to Site.....	3-4
3.2.2 Installation Techniques.....	3-5
3.2.2.1 Precast Concrete Panel Installation	3-5
3.2.3 Connections.....	3-7

Contents continued

CHAPTER 4	Performance Criteria.....	4-1
4.1	Building Science	4-1
4.2	Structural Considerations.....	4-2
4.2.1	Cast-in-place Concrete Building Frame	4-2
4.2.2	Precast Concrete Building Frame	4-3
4.2.3	Steel Building Frame	4-3
4.2.4	Hybrid Building Frame	4-3
4.2.5	Structural Design of Panel Connections.....	4-4
4.2.6	Structural Design of Precast Concrete Panels.....	4-5
4.2.7	Insulating Precast Concrete Wall Assemblies	4-8
4.2.8	Thermal Bridging	4-9
4.2.9	Thermal Mass Effects	4-11
4.3	Air Leakage Control	4-11
4.4	Vapour Diffusion Control	4-12
4.5.	Precipitation Control	4-14
4.5.1	Causes of Water Leakage Across the Building Envelope	4-14
4.5.2	Water Leakage Forces.....	4-14
4.5.2.1	Air Pressure Differences.....	4-14
4.5.2.2	Capillary Action.....	4-15
4.5.2.3	Kinetic Action	4-15
4.5.2.4	Gravity.....	4-15
4.5.3	Water Leakage Control Strategies.....	4-15
4.5.3.1	Mass Assemblies	4-16
4.5.3.2	Drained Assemblies.....	4-16
4.5.3.3	Perfect Barrier.....	4-17
4.5.3.4	Precipitation Design Considerations.....	4-18
4.6	Noise.....	4-19
4.7	Solar and Ultraviolet Radiation.....	4-20
4.8	Fire	4-20
4.9	Durability	4-21
4.10	Energy	4-22
4.10.1	Design of Building Envelope Details	4-23
4.10.2	Thermal Mass Effects	4-23
4.11	Aesthetics.....	4-24
4.12	Life Cycle Assessment.....	4-24
CHAPTER 5	Detailing for Success	5-1
5.1	Design Criteria for Detailing of Precast Concrete Wall Panel Joints	5-1
5.2	Precast Concrete Wall Panel: Edge Joint Design	5-2
5.2.1	Joints as Architectural Treatment.....	5-2
5.2.2	Butt Joints	5-3
5.2.3	Chamfered and Chamfered Reveal Joints	5-3
5.2.4	Recessed or Reveal Joints	5-3
5.3	Precast Concrete Panel Joint Design.....	5-4
5.3.1	Sealant Joints for Single Wythe Wall Panels	5-4
5.3.2	Sealant Joints for Double Wythe Insulated Wall Panels	5-6

Contents continued

5.3.3	Preferred Sealant Installation Practice	5-8
5.3.4	Joint Sizing and Sealant Selection	5-8
5.3.5	Structural Expansion (Contraction) Joints	5-10
5.3.6	Seismic Storey Drift and the Effect on Joint Widths	5-11
5.3.7	Sealant Selection	5-11
5.3.8	Joint Preparation	5-14
5.3.9	Primers.....	5-14
5.3.10	Cold Weather Sealant Applications	5-15
5.3.11	Other Considerations.....	5-16
5.3.12	Sealant Backer Rod	5-17
5.3.13	Installation and Tooling of Sealants	5-17
5.3.14	Durability of Sealants	5-18
5.4	Details Overview.....	5-18
CHAPTER 6	The Design, Tender & Construction Process	6-1
6.1	Quality Assurance and the Design and Construction Process	6-1
6.2	Detailing.....	6-2
6.3	Specifications	6-3
6.4	Tender.....	6-4
6.4.1	Samples.....	6-4
6.4.2	Pre-Bid Conference	6-5
6.4.3	Contract Award	6-5
6.5	Plant Visits	6-6
6.6	Mock-Ups	6-6
6.6.1	Production Approval Samples.....	6-6
6.6.2	Full-Scale Mock-Up on Site	6-6
6.6.3	Periodic Field Review during Construction.....	6-7
6.7	Quality Assurance (QA) Procedures and Documentation.....	6-7
6.8	LEED and Sustainability	6-9
6.8.1	Building Reuse (Materials Credit #1).....	6-9
6.8.2	Construction Waste Management (Materials Credit #2).....	6-9
6.8.3	Recycled Content (Materials Credit #4).....	6-10
6.8.4	Local/Regional Materials (Materials Credit #5)	6-11
6.8.5	Durable Building (Regional Priority #1).....	6-11
6.8.6	Life Cycle Assessment, Environmental Impacts and Resource Measurements.....	6-11
6.8.7	Environmental Product Declarations	6-13
CHAPTER 7	Maintenance	7-1
CHAPTER 8	Glossary	8-1
CHAPTER 9	References	9-1
CHAPTER 10	Bibliography	10-1
	Architectural and Building Science References:.....	10-1
	Technical Bulletins and Manuals:.....	10-1
	Sustainability Resources:	10-1

List of Figures

Figure 2-1: Single wythe (architectural) precast concrete wall panel assembly at slab edge.....2-2

Figure 2-2 Double wythe insulated precast concrete panel assembly.2-3

Figure 2-3: Hand Set Precast.....2-7

Figure 2-4: Precast horizontal panels with column covers.2-9

Figure 2-5: Precast spandrel panels.2-9

Figure 2-6: Precast Punched Window Panels.2-10

Figure 2-7: Solid wall panels with reveals.....2-11

Figure 2-8: Granite veneer concept.2-18

Figure 3-1: Form types.3-2

Figure 3-2: Detail of Sealant and Shim placement.3-7

Figure 3-3: Panel Articulation.....3-10

Figure 4-1: Horizontally and vertically ribbed precast concrete panels.4-5

Figure 4-2: Examples of mass or storage approach to precipitation management.4-16

Figure 4-3: Examples of drained approach to precipitation management.4-17

Figure 4-4: Examples of the perfect barrier approach to precipitation management.....4-18

Figure 4-5: Typical Drip Edges on a Precast Concrete Panel.4-19

Figure 5-1: Joint Types.5-4

Figure 5-2: Detail of Transverse Baffle Joint Locations.5-4

Figure 5-3: Details of a two-stage joint at a drainage/vent hole.....5-5

Figure 5-4: Details of a two-stage joint at a drainage/vent hole.....5-5

Figure 5-5: Sealant joint detailing for double wythe precast concrete insulated wall panel.....5-7

Figure 5-6: Proper Joint Sealant Profile.....5-9

Figure 5-7: Proper Joint Sealant Profile.....5-9

Figure 6-1: Visual Schematic of the Sustainable Plant Tracking Program showing the input materials through their life cycle stages of extraction, processing, and finally their optimization in the precast manufacturing process.6-12

List of Detail Drawings

Detail drawing 5-1: Single wythe precast panel—bottom bearing and lateral foundation wall connection.....5-20

Detail drawing 5-2: Single wythe precast panel—lateral foundation wall connection.5-21

Detail drawing 5-3: Single wythe precast panel—suspended soffit.....5-22

Detail drawing 5-4: Single wythe precast panel—slab bearing connection.....5-23

Detail drawing 5-4a: Single wythe precast panel—slab bearing connection total precast.....5-24

Detail drawing 5-4b: Single wythe precast panel—slab bearing connection total precast.....5-25

Detail drawing 5-5: Single wythe precast panel—lateral connection at parapet.5-26

Detail drawing 5-6: Single wythe precast panel—window head/sill connection.....5-27

Detail drawing 5-7: Single wythe precast panel—window jamb connection.5-28

Detail drawing 5-8: Single wythe precast panel—connection to curtain wall jamb.5-29

Detail drawing 5-9: Single wythe precast panel—connection to EIFS cladding.5-30

Detail drawing 5-10: Connection to precast panel—junction at brick veneer cladding.5-31

Detail drawing 5-11: Single wythe precast panel—projecting exterior column cover.5-32

Detail drawing 5-12: Double wythe precast panel—bottom bearing foundation wall connection.....5-33

Detail drawing 5-13: Double wythe precast panel—suspended soffit and lateral connection.5-34

Detail drawing 5-14: Double wythe precast panel—bearing connection to slab edge.5-35

Detail drawing 5-14a: Double wythe precast panel—bearing connection total precast.....5-36

Detail drawing 5-15: Double wythe precast panel—lateral connection at parapet.5-37

Detail drawing 5-16: Double wythe precast panel—connection to door head.....5-38

Detail drawing 5-17: Double wythe precast panel—connection to door jamb.....5-39

Detail drawing 5-18: Double wythe precast panel—window head/sill connection.....5-40

Detail drawing 5-19: Double wythe precast panel—connection to curtain wall.5-41

Detail drawing 5-20: Double wythe precast panel—service penetrations.5-42

Detail drawing 5-21: Double wythe precast panel—connection to brick veneer cladding.....5-43

CHAPTER 1 Introduction

1.1 Context / Background

Architectural precast concrete wall panels have been used as cladding on buildings since the 1920s and have become increasingly popular since the 1950s. In the last 10 years, the range of products has broadened as manufacturers have incorporated new manufacturing methods, new finishing techniques and materials, new insulating and anchoring methods as well as improved methods for addressing rain, wind, vapour and heat movement. Current panel types include single wythe wall panels and double wythe insulated wall panels.

Concrete has the advantage that it can be formed to any shape while in its plastic state and then once cured, is virtually indestructible. A wide range of design aesthetics can be achieved through the use of reveals and rustication, form liners, stencils, sandblasting techniques, set retarders and facings. Various materials may be cast into or attached onto the face of panels to supplement the colours and textures attainable with conventional finishing methods. Natural stone, clay masonry, tile and other materials have been attached to precast panels to provide additional choices of exterior or interior finish as well as colour and texture.

Architectural precast concrete wall panels are fabricated under controlled factory conditions to exacting tolerances and manufacturers are now producing thinner panels with simplified connections. Composite panels with “punched windows”

(See Chapter 2) can provide the entire wall assembly from a single source. Year-round construction is possible with panels that are quickly erected at the site, providing the opportunity to rapidly enclose a building and speed up construction.

Architectural precast concrete wall systems, like others, are sensitive to the installation and performance of each component and those adjacent to



*A variety of shapes and textures can be created with architectural precast panels.
Source: M. E. Hachborn Engineering*

it. It is important to consider the overall requirements of the building envelope during both the design and the construction stages. Understanding how architectural precast concrete can be utilized as an integral part of the complete building envelope enables designers to make appropriate design choices.

1.2 The Purpose of this Best Practice Guide

The purpose of this Best Practice Guide is to summarize the most current information and best practices in architectural precast concrete wall construction and to provide designers with an understanding of this construction system by illustrating recommended design details and site practices.

This Guide is organized to take the user through the design and construction process starting with a discussion of the characteristics of architectural precast concrete, then present the fundamentals of building science, building envelope performance and how precast concrete fulfils these performance criteria, and finally end with an explanation and illustration of current best practice assemblies, details and specifications. This guide is intended for use when designing occupied spaces that require all of the building envelope separation criteria described in Chapter 4. Chapter 6 outlines quality assurance considerations during the design, fabrication and erection processes, and Chapter 7 introduces the reader to maintenance and renewal practices, post-construction and during the service life of the precast concrete panels. Chapter 8 includes details to illustrate how precast concrete wall panels can be used effectively to create a superior building envelope solely as a cladding or while also functioning as part of the structure.

The Guide does not consider the requirements of architectural precast that is installed as the façade of unenclosed structures such as parking garages and stadiums. As well, the Guide does not consider the requirements of architectural precast that is installed on a building with extreme interior environmental conditions. Finally, the Guide does not address unusual structural issues or the structural requirements of load-bearing architectural precast.

Disclaimer: This Guide is not intended to replace professional expertise. When the information contained within this Best Practice Guide is used as guidance and incorporated into the design of buildings, it must be reviewed by knowledgeable engineering and building envelope professionals and reflect the specific and potentially unique conditions and design parameters of each building. Readers are advised to evaluate the information, materials and techniques cautiously for themselves and to consult appropriate professional resources to determine whether information, materials and techniques are suitable for their application. The drawings and text are intended as general best practice guidelines only. The project and site specific factors of climate, cost, aesthetics, and so on must be taken into consideration. Use of the Guide does not relieve designers of their responsibility to comply with local building codes, standards and bylaws with respect to the design and construction of the building envelope.

1.2.1 The Canadian Precast/Prestressed Concrete Institute

The Canadian Precast/Prestressed Concrete Institute (CPCI) is the body of knowledge (BOK) for precast concrete in Canada and represents the manufacturers of precast concrete in Canada. CPCI's member plants produce more than 85% of the precast concrete manufactured annually in Canada. The institute's primary responsibility is to advance the body of knowledge and the use of structural, architectural and specialty precast concrete for the precast industry in Canada. The CPCI conducts research, develops and disseminates technical standards and other best practice information relating to the design, production, and erection of precast concrete structures of all types. Through the certification of personnel, facilities, and processes involved with precast concrete, the goal is to improve the quality and durability of precast concrete and increase the demand for precast concrete products in Canada (www.cpci.ca).

The *CPCI Precast Concrete Certification Program for Structural, Architectural and Specialty Precast Concrete Products and Production Processes* was designed and implemented to qualify and increase the capabilities of

manufacturers who fabricate structural, architectural and specialty precast concrete products. The purpose of the audit based program is to provide owners and designers with the confidence that when a CPCI certified precast concrete manufacturer is awarded a contract, the precaster will be qualified to manufacture the products they supply to the marketplace, are competent to provide quality precast and have adequate personnel and facilities to do so. The intent of this program is to certify only those precast manufacturers who demonstrate strict conformance to current standards, and who are committed to continually improving the quality of their products and systems. The CPCI Certification program has reintroduced common, measurable, nationwide standards for precast certification. In accordance with the requirements of the National Building Code of Canada, CPCI Certification is aimed to make the CPCI certification designation, a recognized requirement for all project specifications and for all precast operations. CPCI Certification should always be the default certification in architectural specifications. More information can be found in Section 3.1.4 or by visiting www.precastcertification.ca.

1.2.2 Other Related Building Science Publications

This Guide is the Fourth in a series of architectural precast building envelope guides prepared by and for the Canadian Precast / Prestressed Concrete Institute. It supercedes all similar previous guides on this subject matter published by others.

The other three guides in this series, authored by Dr. John Straube, RDH Building Science, are essential reference documents for any designer of a precast wall assembly. They are: 1) *High Performing Precast Concrete Building Enclosures: Rain Control*, 2) *Maintenance and Inspection Manual for Precast Concrete Building Enclosures*, and the newest addition released in 2017, 3) *Meeting and Exceeding Building Code Thermal Performance Requirements*.

1.3 Technical Review

This document was prepared by primary author M. E. Hachborn Engineering in conjunction with the CPCI Technical Committee. Additional assistance was provided in part by Bruce Taylor and Morrison Hershfield Limited.

Members of the technical committee of CPCI (2017):

Sonia Saari (Chair) – Coreslab Structures (Ont) Inc.
Anil Mehta (Vice Chair) – Prestressed Systems Incorporated
Chris Christidis – Sika Canada Inc.
Dr. Ned Cleland (PCI Liaison) – Blue Ridge Design Group
Osama Eissa – IES Associates
Dr. Paul Gauvreau – University of Toronto, Department of Civil Engineering
Dr. Medhat Ghabrial – HGS Ltd
Malcolm Hachborn – M. E. Hachborn Engineering
Wayne Kassian – Kassian Dyck Associates
Bill LeBlanc – Armtec
Raymond Lee – Lafarge
Ifan Lim – Lafarge
Dave Marshall – Black Mint Software Inc.
Mel C. Marshall – MCM Industrial consultants, Inc.
Richard J. McGrath (CAC Liaison) – Cement Association of Canada
Dr. Dave Rogowsky – UMA Engineering Ltd.
Don Simms – Armtec
Karl Truderung – Tower Engineering Group
Clark Weber – Bluerock Engineering Ltd.
Robert Burak (CPCI President) – CPCI

CHAPTER 2 Architectural Precast Concrete Wall Panels Defined

An architectural precast concrete wall panel is a high quality, durable, economical, sustainable, factory produced cladding panel with the inherent architectural features of shape, colour, texture and finish that can provide the aesthetic and all of the specified building envelope performance requirements for the exterior wall (see Chapter 4).

Architectural precast concrete wall panels are of consistent high quality as they are produced in the controlled environment of a CPCI certified precast plant by certified personnel using quality materials. The high quality of manufacture ensures the durability of the product which ultimately leads to its sustainability.

Finish selection requires an understanding of how the panels are manufactured and the effects material selection has on mix design, finish consistency and durability. For instance, the selection of architectural aggregates, local to the manufacturer will typically be more cost effective and have a lower environmental impact, owing to the shorter shipping distances.

The use of architectural precast concrete wall panels is cost-effective for many reasons, including production in a controlled environment and reduced site construction time and site labour. The advent of larger capacity hauling and lifting equipment has allowed precasters to install larger panels and reduce construction time, enclosing the building more quickly. This can be very beneficial in regions with a shorter construction season such as the majority of Canada.

Typically, architectural precast concrete wall panels used as cladding are supported from the structure. The gravity, wind and seismic loads must be resisted by the panels and the resultant loads transferred to the structure through the connections. The *CPCI Design Manual* and CSA Standard A23.4-16 "Precast Concrete—Materials and construction" provide useful guidance.

2.1 Panel Types

Architectural precast concrete wall systems can vary in complexity from simple, non-loadbearing single wythe wall panels, to load bearing double wythe insulated wall panels with preinstalled windows that function as the entire environmental separator. All panel types allow designers to choose from a wide selection of panel finishes, such as textured concrete, brick, stone, or other material integrated within the precast concrete panel.

2.1.1 Single Wythe Precast Concrete Wall Panels

Single wythe wall panels, also commonly referred to as "conventional" or "architectural" precast concrete panels, traditionally consist of a single exterior wythe that incorporates the desired finish and the required structural parameters of the cladding system. Single wythe wall panels may be used in a non-insulated wall assembly, but may also include a variety of site-constructed additional elements to complete the full building envelope assembly.

Non-insulated systems are suitable for unheated spaces such as dry warehousing and parking garages. Single or preferably two-stage joints control air, vapour and water leakage through the joints. Non-insulated systems utilizing precast panel wall assemblies are outside the scope of this Best Practice Guide.

This guide is intended for use when designing occupied spaces that require all of the building envelope separation criteria described in Chapter 4.

Single wythe precast concrete wall panels with two-stage drained joints are sometimes referred to as “single skin”, “perfect barrier” systems. The very low porosity of the plant-fabricated precast concrete acts as a robust weather barrier. The precast concrete panel is typically installed first onto a structural frame.

This is followed by other trades erecting interior, non-structural studs (not carrying wind loads), insulation, air/vapour barrier and interior gypsum finishing wall board. Alternatively, adhered insulation installed with a vapour barrier (or spray-applied urethane insulation) combined with steel studs provides economical commercial and institutional enclosures.

In this type of assembly, two-stage joints are preferred for effective and long lasting control of rain penetration and air and vapour leakage (See Section 5.3). The two seals are installed from the exterior of the building, thereby ensuring a continuous seal by avoiding the interruptions caused by the interferences of beams and columns and simplifying construction sequencing. The exterior seal provides a protective weather seal to the interior seal, while the interior seal can serve as the air barrier while being protected from the elements, leading to improved performance and durability. Any moisture, condensation or frost occurring in the joint space behind the exterior weather seal is drained to the exterior or dried with the exchange of air through the vent openings. The two-stage joint detail is referred to as a “drained joint” and is unique to precast wall systems.

2.1.2 Double Wythe Precast Concrete Insulated Wall Panels

Double wythe insulated wall panels are also commonly referred to as “insulated panels” or “sandwich” panels. Straube (2013) also uses the term “double wythe integrally insulated wall panels with two-stage joints”. These

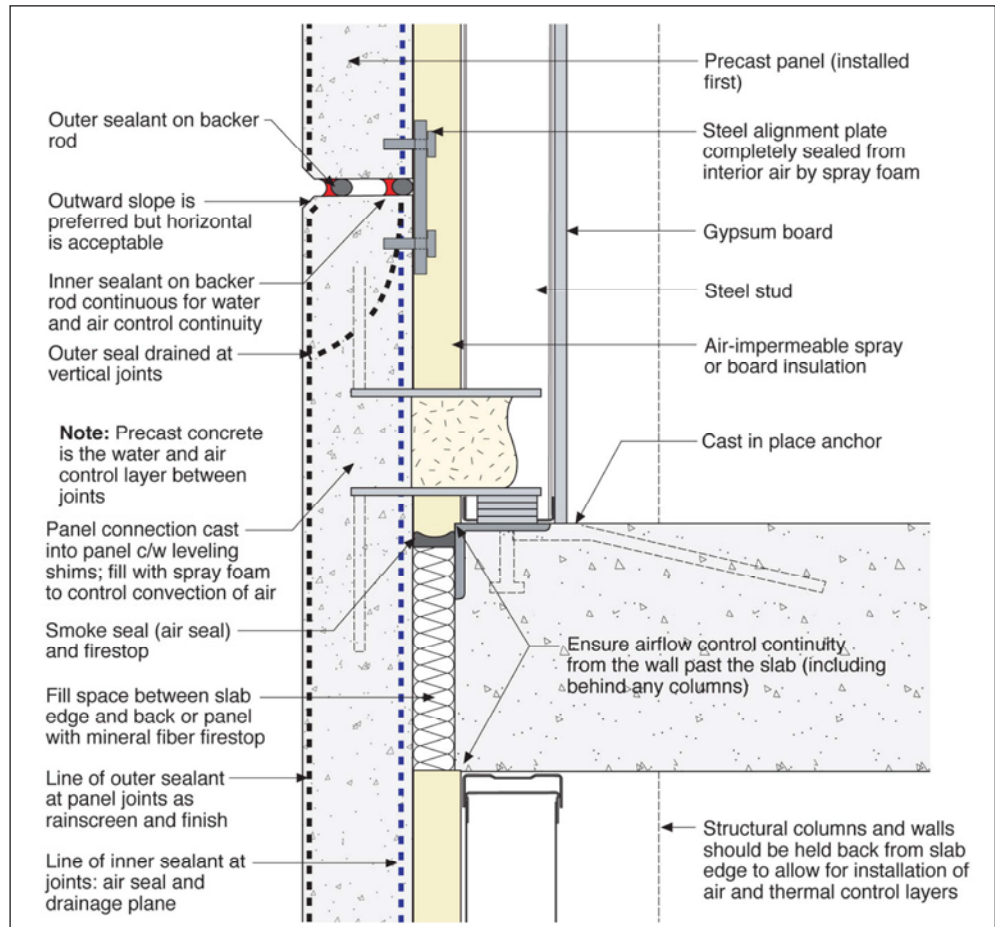

Figure 2-1: Single wythe (architectural) precast concrete wall panel assembly at slab edge. Image copyright RDH Building Science Inc., used with permission

panels incorporate thermal insulation, generally extruded or expanded polystyrene, between an exterior “architectural” wythe and an interior “structural” wythe. Double wythe insulated wall panels can vary in thickness, and typically range from 170 mm to 350 mm in total thickness depending on panel size and thermal performance requirements. A typical panel consists of a minimum 75 mm exterior architectural precast concrete wythe, a layer of thermal insulation governed by thermal performance requirements, and an interior wythe with a thickness governed by structural requirements. For more information on thermal performance requirements, refer to the RDH Building Science guide document *Meeting and Exceeding Building Code Thermal Performance Requirements*.

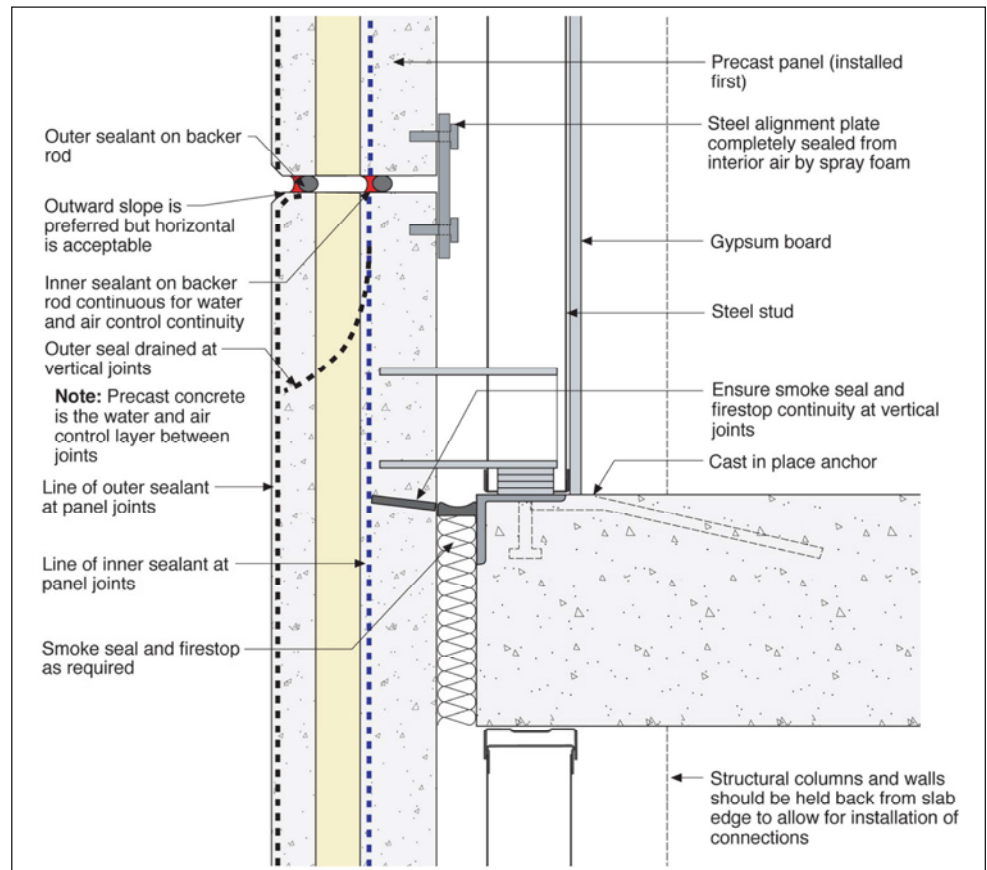

Figure 2-2 Double wythe insulated precast concrete panel assembly.
Image copyright RDH Building Science Inc., used with permission

The very low porosity of the plant fabricated precast concrete wall panel provides a very robust weather barrier. A two-stage joint, similar to that used in the single wythe wall panel system is installed from the exterior, thereby ensuring a continuous seal by avoiding the interruptions caused by the interferences of beams and columns if installed from the interior and simplifying construction sequencing. The interior seal acts as the air barrier and vapour retarder and is installed along the exterior edge of the interior or “structural” wythe. The exterior weather seal is installed along the exterior edge of the exterior wythe to complete the joint detail as in the single wythe precast wall system. Any moisture, condensation or frost accumulating in the joint space in front of the interior seal but behind the exterior weather seal is drained to the exterior, or dried, with the exchange of air, through the vent openings in the joint.

Fabrication: During fabrication of the double wythe insulated precast concrete wall panel, connecting ties (commonly called “tension/compression ties” or “wythe ties”) are embedded in the exterior wythe (typically cast face down), then rigid insulation is applied with or without a polyethylene bond breaker on top of and against the front face of the interior wythe. The interior wythe is then cast onto the insulation or bond breaker, if used, to complete the panel. The ties must be designed to support the exterior wythe through the fabrication, transportation and erection processes. They must also accommodate the differential thermal movement which will occur because of the large thermal fluctuations of the exterior wythe compared to the interior wythe as a result of the insulation between the wythes. Some precasters manufacture the panels with the interior wythe down against the form and the exterior wythe up in a reverse configuration to produce a very smooth interior faced panel with

a rolled exterior profile and finish. This is normally done for warehouses, distribution centres or clean room type structures in order to provide the smooth interior and where a precise architectural exterior finish is not required.

For typical double wythe insulated wall panels, the use of an internal drainage layer within the x-y plane of the panel construction is not considered necessary and in many ways can be considered a negative attribute that can lead to premature failure of the wall system. (See section 2.2.1).

Veneer panels: Double wythe insulated wall panels may also be constructed with granite or limestone exterior veneer, but rarely as the sole outer wythe. With these types of panels, it is recommended that a concrete exterior wythe be used to “hold” or support the veneer. Unlike the previously described single wythe wall panels and double wythe insulated wall panels, in this type of panel an “air space”, “cushion” or “bond breaker” is introduced behind the veneer material for drainage of any moisture passing through the veneer material. This is due to the increased number of joints in the veneer, the higher possibility of moisture migrating through the veneer owing to the potentially higher porosity of the veneer material versus concrete and differing rates of thermal expansion of the veneer material and the concrete. (See sections 2.5.3 and 2.5.4).



Double wythe precast concrete insulated wall panel being installed. Source: CPCI

There are generally two types of double wythe insulated precast concrete wall panels:

1. Non-composite – Double wythe insulated wall panels where the outer wythe is supported by the inner wythe with relatively flexible ties and hangers that permit differential movement between the two wythes caused by varying temperature and humidity conditions. The inner wythe is generally thicker and stiffer than the outer wythe. The structural interior wythe is designed to resist all structural and wind loads applied to the panel. Non-composite panels allow differential thermal movement between the inner and outer wythes thereby reducing thermal bowing in the panel.
2. Composite – Double wythe insulated wall panels where the inner and outer wythes are interconnected via rigid ties or shear transfer mechanisms that act as webs in the panel to limit relative movement between the wythes. Composite panels have thinner wythes as both contribute to the panels rigidity as the inner and outer precast wythes act together to make the panel behave like an I beam when resisting the externally imposed loads. In this configuration the *potential* for thermal bowing is significant and must be recognized and considered in the design of both the panel and the connections.

Key advantages of the double wythe insulated precast concrete wall panel system include:

- Complete exterior wall in one unit, completed under factory conditions, including exterior finish, insulation and structural interior wythe (with or without an interior finish).
- When windows are installed in the panels, the entire panel area is virtually complete once installed on the structure, and
- the drained joint for reliable control of air and water leakage.

Design and Construction Considerations:

1. Interior structural wythes are typically a minimum of 100 mm thick, but can vary depending on the nature of the panel (composite or non-composite), the structural design requirements; exterior wythes are typically a minimum of 75 mm if concrete only, and a minimum of 90 mm if faced with other products such as thin brick, marble, limestone or granite. Thinner sections can be used if nonmetallic reinforcing is used as cover requirements can be somewhat reduced. Cover requirements must always meet those specified in CSA 23.4.
2. Panels with architectural “false joints” may require additional thickness to maintain minimum cover requirements. Review reinforcement cover and aggregate size with potential precasters.
3. As a rule of thumb, the maximum panel dimension for composite panels is generally limited to 48 times the overall concrete thickness, excluding the thickness of the insulation. Consult the precast manufacturer for maximum panel size as there may be plant, transportation, erection or other limitations.
4. Maximum panel weights can vary by precast manufacturer due to factors such as materials, experience, plant capacity (including in-plant crane capacity) and capacity of shipping equipment. Project specific weight limitations are governed by applicable shipping regulations, jobsite crane capacities, and handling equipment.

2.2 Other Panel Configurations

2.2.1 Drained Assemblies – Single and Double Wythe Insulated Precast Concrete Wall Assemblies with ‘rain screen’ drainage layer – Not recommended but discussed

There has been a significant amount of discussion in the design community and the precast industry on the applicability of incorporating a 10 to 25 mm ‘rain screen’ drainage layer (or air space) as part of a precast concrete drained wall assembly. Some designers propose to introduce the additional drainage layer behind the face wythe of a precast panel wall assembly due to the mistaken belief that the precast panel will allow water penetration through the field of the panel similar to brick masonry. Precast concrete panels are sufficiently water tight in and of themselves to not require this additional layer. These additional layers are not required nor recommended for designs that use the previously described two stage drained joint system for single wythe wall panel or double wythe insulated wall panel configurations. This statement is supported by years of demonstrated performance. **For more discussion on this issue, please refer to *High Performing Precast Concrete Building Enclosures: Rain Control* by RDH Building Science, Inc.**

The addition of the rain screen “drainage layer” air space introduces significant additional risks to the successful performance of the overall wall with regards to water tightness and air tightness, and these risks outweigh the perceived benefits of design intent. These types of panel configurations are no longer recommended or used by building science professionals and designers for precast concrete wall assemblies, especially those who have researched these systems in the context of state of the art building science principles.

A summary of the added risks include as follows:

1. Interruption of precast panel seals in a single wythe precast concrete wall panel system at the through-wall flashing locations needed to drain this additional drainage layer. The interruption of the seal means that the two-stage joint can no longer perform as a complete air barrier seal, thus allowing air penetration and movement into this added drainage layer, which will allow water infiltration or accumulation due to air movement and the accumulation of condensation.
2. There is an increase in overall system construction complexity to ensure proper air barrier, vapour barrier, and water management layer continuity. This complexity is accentuated at the intersection of the introduced drainage layer and the precast panel anchors, where it now becomes difficult to

ensure the continuity of the air, vapour and water management layers while still allowing for proper precast panel anchor installation.

3. The introduction of a separate air barrier layer in the wall system must also be integrated with the back-up wall construction. When located at the exterior face of the back-up wall construction, this air barrier layer must be constructed prior to the installation of the precast panels, which will then be compromised when the precast anchors are installed. Penetrations must be provided through the introduced air barrier layer for the panel anchors and once the precast panels are installed, these penetrations must then be properly sealed. When one considers the construction sequencing, the complete, impermeable air barrier backup wall, once constructed, would be punctured and compromised in multiple locations to accommodate the fastening of the precast panels. Depending on panel size and loading, every precast panel requires a minimum of 4 and sometimes up to 10 connections to the structural frame (See section 3.2.3). Therefore, a structure with 500 panels would require at least 2000 penetrations, and potentially 5000 penetrations (if the panels are large) that would be introduced into this newly constructed barrier layer– and these would all require resealing.
4. There is an increased opportunity in the winter for interior warm air to bypass the insulation layer and find its way into the “cold” drainage layer, resulting in condensation accumulating on the back of the panels and in the cavity, creating water problems, a loss of thermal performance and an increase of the loads on connections. This phenomenon has been observed with significant consequences.
5. There is an opportunity for the introduction of a significant amount of water into the body of a double wythe insulated precast concrete wall panel with an integral drainage layer due to wind gusts related to the stiffness of the panel wythes and the pressure equalization of the drainage cavity within the wall panels.
6. The compartmentalization of the joints is almost impossible as the drainage layer would also have to be compartmentalized and all compartmentalizing beads would have to coincide. Logistically, this is impossible to achieve and verify.

2.2.2 Thin Veneer Single Wythe Wall Assembly

Thin veneer systems are typically “handset” thin precast concrete panels that are used with a “grid pattern” panel support structure, in a similar manner to that used for metal, ceramic, porcelain, limestone, granite or marble panel systems.

Unlike typical single and double wythe insulated precast concrete wall systems, small handset thin veneer single wythe assemblies should include a drained air space behind the exterior cladding elements, since there would be a large number of joints making them more susceptible to incidental water penetration. These systems must include proper air, vapour, insulation, and water management layers integrated into the overall wall design.

2.3 Wall Panel Layout (and its effect on joints)

Panel layout has a direct effect on joint location. The choice of the joint locations and the joint configuration can be as important as, if not more important than, the panel design itself. These are the areas that require the most attention, to minimize the risk of water and air leakage in architectural precast wall assemblies. This includes the



Handset precast panels installed in a drained wall system. This approach might be necessary for retrofit projects but is discouraged for new projects. Image copyright RDH Building Science Inc., used with permission

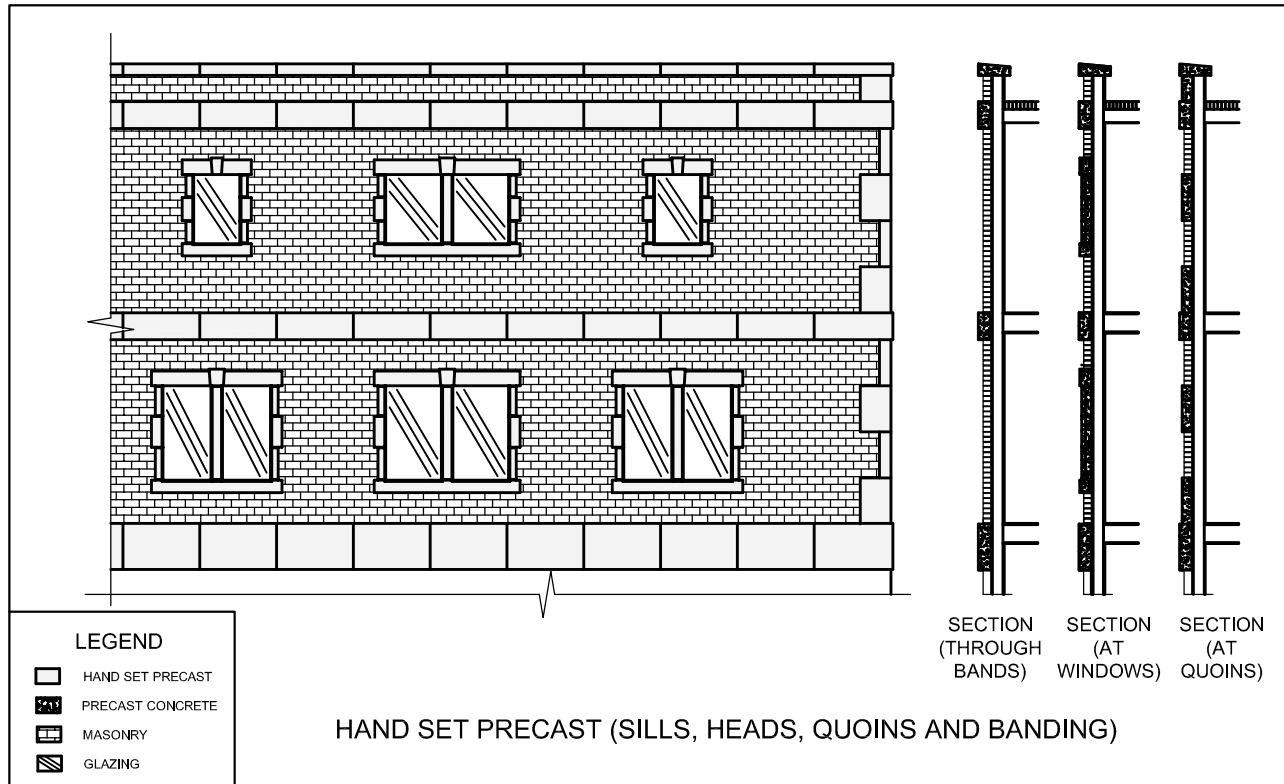

Figure 2-3: Hand Set Precast. Source: M. E. Hachborn Engineering

joints between panels, joints at the interface with other material types, and joints at the interface of windows and doors. Details for interfacing are covered in Chapter 5.

When considering panel layout, the number and location of joints in the architectural design should be minimized to reduce the risk of water and air leakage. Water and air leakage may occur when either: 1. The sealant reaches the end of its typical service life and starts to fail, 2. The sealant is not maintained according to the sealant manufacturer's guidance, or 3. Premature joint failure occurs due to poor adhesion or poor joint profile. See Section 5.3 on ways to avoid possible sealant failure and Chapter 7 on maintenance.

Panel layout is important for all precast systems. It is particularly important with double wythe insulated precast concrete wall panels as they provide all of the building science functions in one system. When installed with the recommended two-stage jointing system, they provide an excellent continuous thermal insulation layer, an air and vapour barrier and act as the rain screen or perfect barrier as integrated components within the overall precast panel design. However, the joints between panels, since they can act as discontinuities in the wall system when not addressed properly, must be located such that they can be easily and properly sealed. Joints between panels are typically located near structural elements, and designers must locate panel joints to avoid problems of access for sealant installation, maintenance and replacement. Panel size must also reflect the realities of precast panel manufacturing, transportation, and job-site handling.

2.3.1 Categories of Precast Panel Layout

Precast panel layout on a facade has a large impact on joint complexity and the costs of sealant material and installation. Panel sizes should be maximized to minimize the total number of joints and hence the total joint sealant length. Panel size must also reflect the realities of precast panel manufacturing, transportation, and job-site handling. Only joints essential to accommodate panel and structural movement should be provided (false joints to simulate real joints may be added if desired for appearance). Most panel layout schemes fall into the following four categories:



*Precast horizontal panels with column covers.
Source: M. E. Hachborn Engineering*



*Alternating bands of Precast
Panels and Windows.
Source: CPCI*



*Punched windows within precast
panels. Source: CPCI*

2.3.1.1 Horizontal Precast Spandrels with Vertical Column Covers

- Horizontal span dimensions as determined with the manufacturer.
- Column covers to introduce the vertical elements of the design.
- Joints at window heads and sills, and at column covers.
- May require the addition of “false” joints to achieve architectural effects.
- Column covers may be incorporated as part of spandrel panels.

2.3.1.2 Alternate Bands of Precast Spandrels and Glazing

- Often called “ribbon window” installation.
- Horizontal span dimensions as determined with the manufacturer.
- Joints between windows and panels.
- May require the addition of “false” joints to achieve architectural effects.

2.3.1.3 Punched Windows

- Maximum panel dimensions to be determined with the manufacturer. Integration of panels sizes and structural bay widths is important to coordinate anchor locations and harmonize the building aesthetics. Panels typically span horizontally with one or more punched window locations or vertically, more than one floor height.
- Location of horizontal joints above the floor line will allow for cleaner two-stage joint seal installation, and allow for flexibility of anchor installation. Coordination with the manufacturer is important.
- Vertical architectural visual elements can be integrated with the panel joints as desired.
- To prevent precipitation concentration at joint locations, locating vertical and horizontal precast joints in line with window jamb, head, or sill lines is not recommended.
- The panel-to-window joint is controlled by the precaster.

2.3.1.4 Solid Wall Panels

- False joints are often used to delineate floor lines, but also for visual effect.
- Locate horizontal joints above the floor line to allow for easier two-stage joint seal installation, and allow for flexibility of anchor installation. Coordination with the precast manufacturer is important.

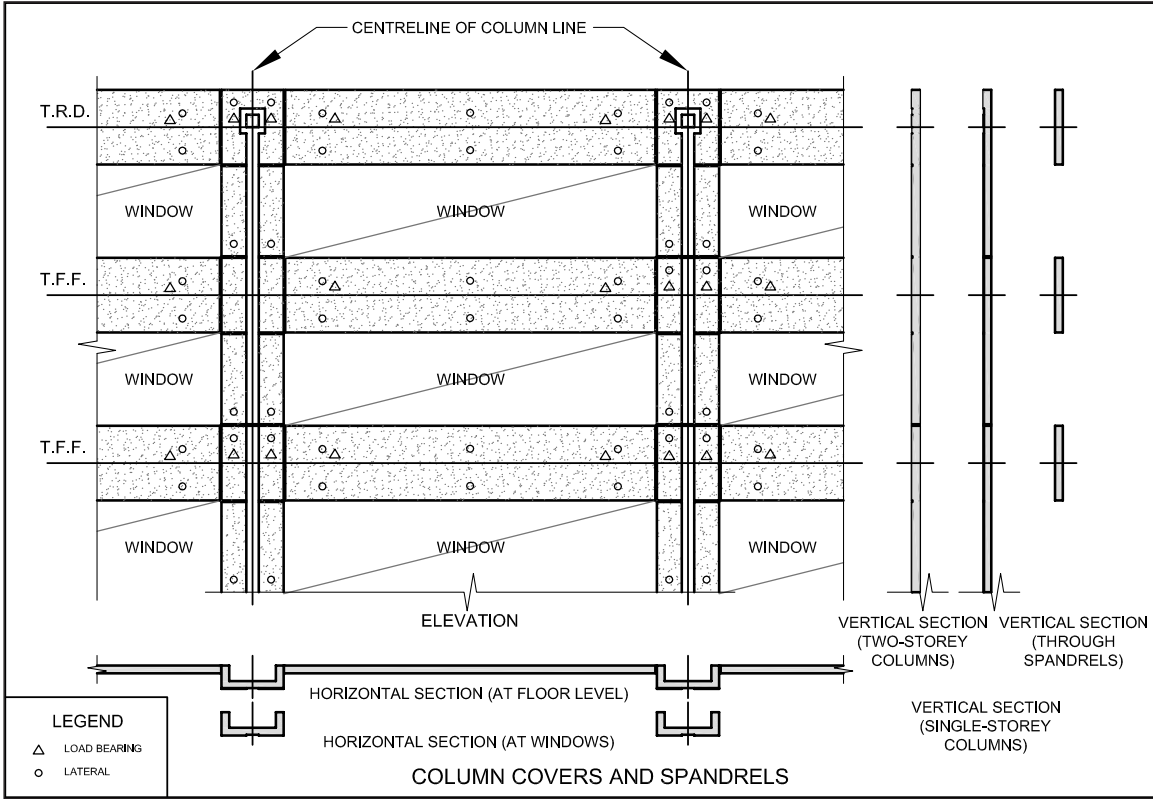

Figure 2-4: Precast horizontal panels with column covers. Source: M. E. Hachborn Engineering

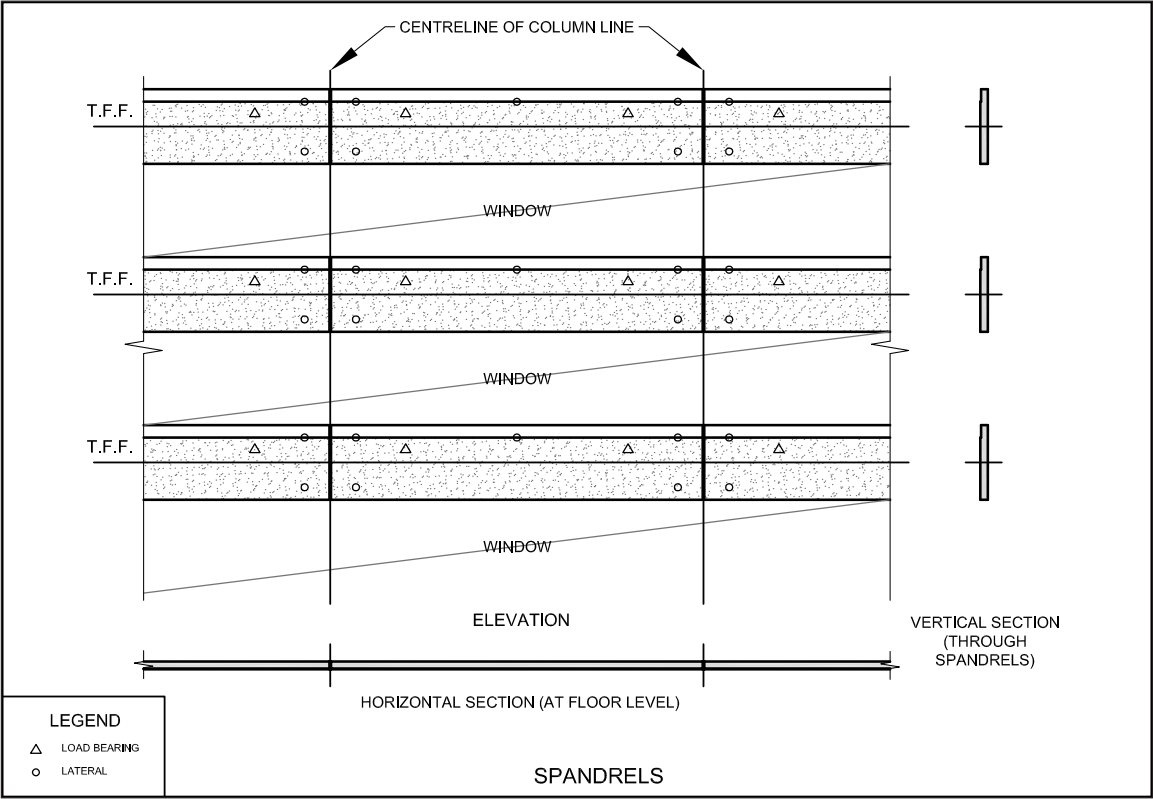

Figure 2-5: Precast spandrel panels. Source: M. E. Hachborn Engineering

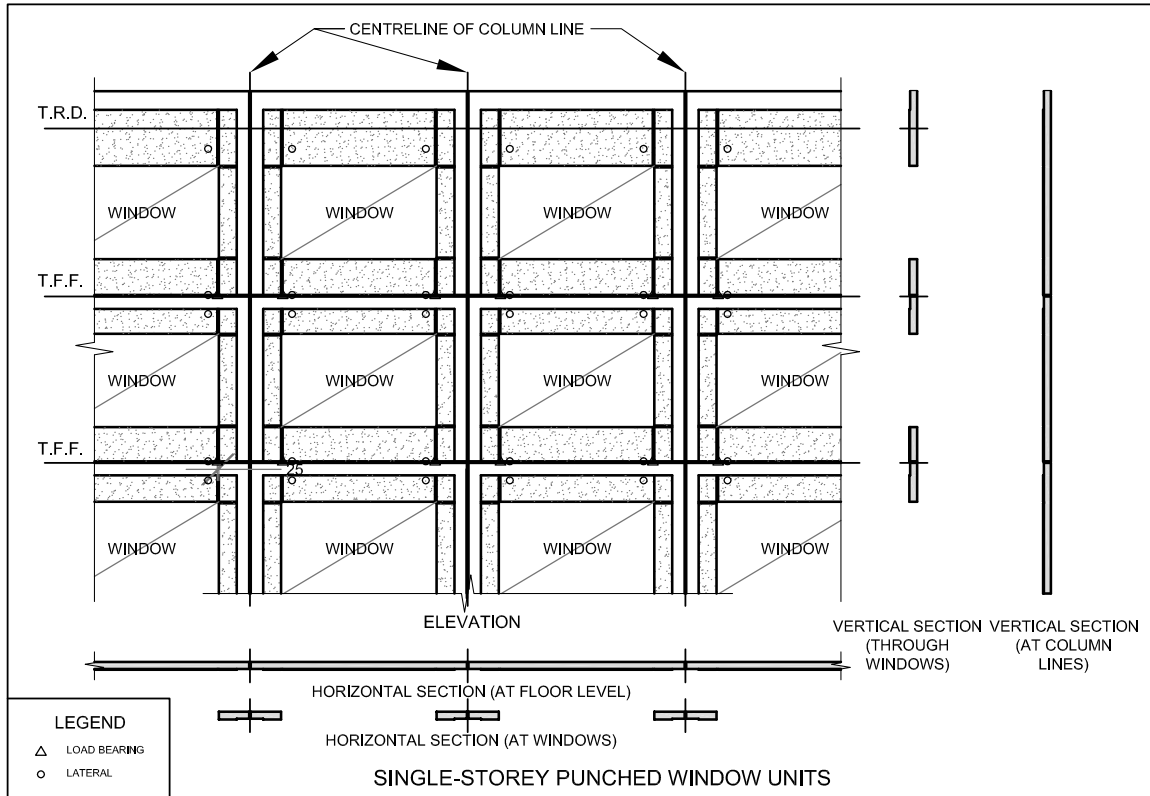

Figure 2-6: Precast Punched Window Panels. Source: M. E. Hachborn Engineering



Solid wall panels with alternating patterns of smooth and ribbed textures. Source: CPCI

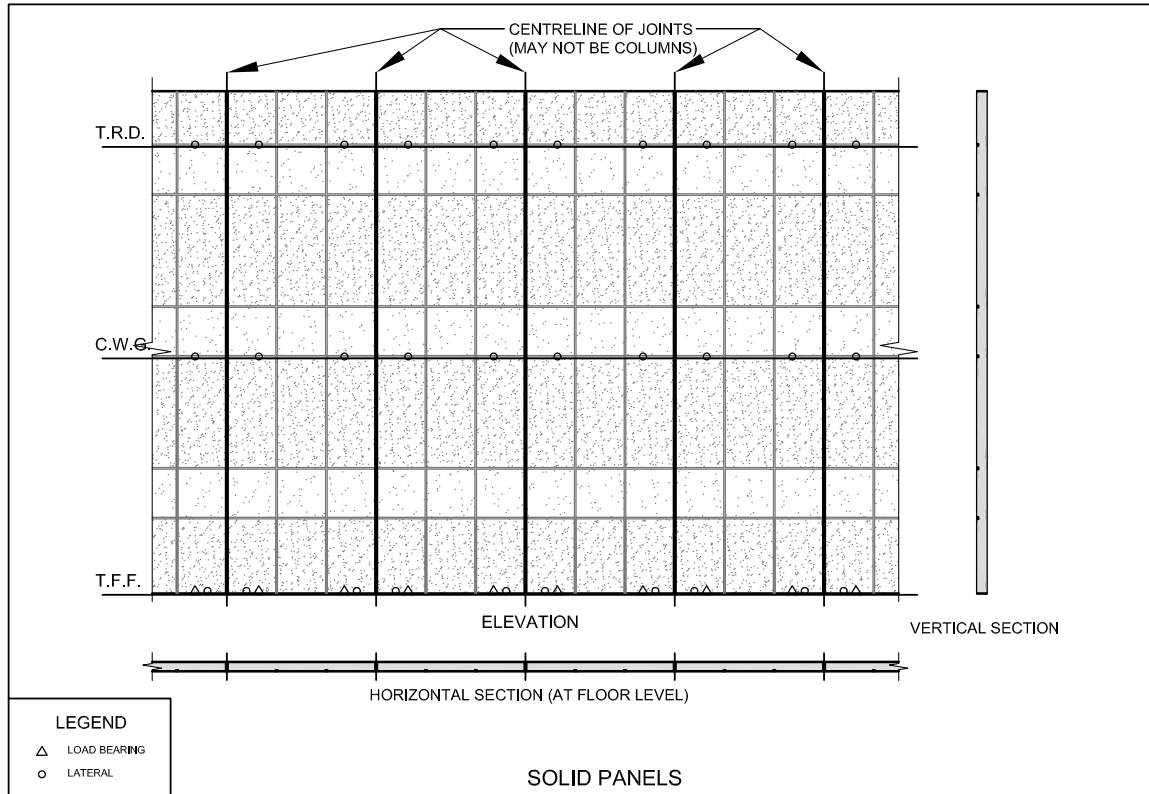

Figure 2-7: Solid wall panels with reveals. Source: M. E. Hachborn Engineering

2.3.2 Double wythe insulated wall panel sizes

The size of double wythe precast concrete insulated wall panels will be determined primarily by architectural design considerations and the capability of the local precast manufacturers.

- The maximum panel dimensions and weight should be determined based on manufacturing, handling, transportation and installation limitations.
- The maximum dimension of composite double wythe precast concrete insulated wall panels will generally be in the order of $L = 48t$, where "L" is the maximum dimension and "t" is the overall panel thickness, excluding the thickness of any ribs or other architectural features.
- The maximum dimension of non-composite precast concrete insulated panels will generally be in the order of $L = 48c$, where L is the maximum panel dimension and c is the concrete thickness, i.e. the overall panel thickness less the thickness of the insulation.
- Typical panel thickness can vary from 170 to 350 mm depending on structural design considerations and the required thermal performance.

Consult the *CPCI Design Manual* and CPCI members for specific design information. CPCI members can assist in the optimization of the building design for maximum economy by using the manufacturer's standard panel widths as much as possible. The designer is encouraged to seek input from precast manufacturers in the design development discussions to ensure that the desired design and sizes can be properly accommodated.

2.4 Colours, Finishes, and Veneers

The versatility of precast concrete gives designers a freedom that is not available with most other materials. The proper selection of concrete matrix colour, aggregate type, colour and combinations, finishing process, and profiles is instrumental in creating successful aesthetics. The development of samples, generally 300mm x 300mm x 25mm thick, by a preferred precast manufacturer, will help in the final selection of colour and texture at the pre-bid stage. As sample preparation requires considerable effort, credit should be given to the pre-bid sample manufacturer. Following project award, final samples will be required from the successful bidder to confirm finish capability as different material sources and manufacturing techniques may influence the final product finish. These samples should be reviewed and approved by the owner’s representative under wet, dry and a variety of lighting conditions. Three or four panels (range samples) of approximately 1200 x 1200 mm to 1800 x 1800 mm are required to establish an acceptable range of colour and texture. These range samples can be kept at the precast manufacturer’s yard or sent to the site for the architect’s review of panels on site.

In addition, prior to full production, a full size, mock-up should be produced and finished in accordance with the proposed production techniques. Mock-ups may be required to confirm compliance with the approved samples and confirm the architectural intent. Mock-ups are not normally required before contract award unless the owner or architect is prepared to pay for



A variety of visually pleasing patterns and textures can be created with architectural precast wall panels. Source: CPCI

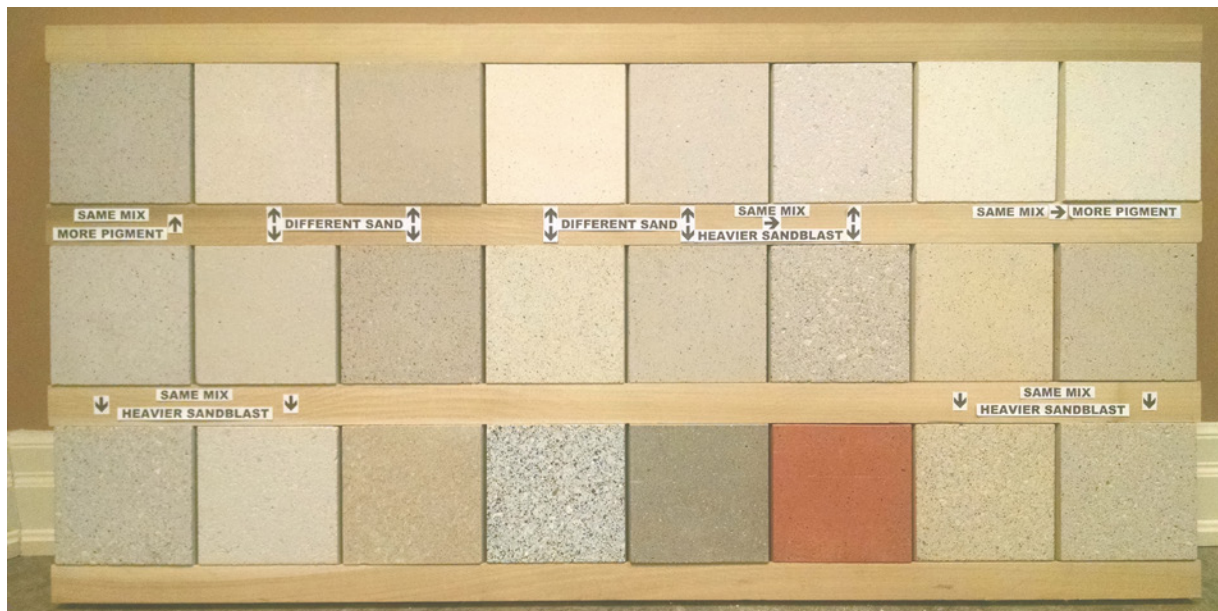

Sample Board. Source: M. E. Hachborn Engineering



Depth of sandblast or acid etching can produce distinct colours. Source: CPCI

them. These full or partial scale mock-ups illustrate the finished product and should include panel elements such as reveals, corners, returns and other unique features. The architect may also require proof of repair capabilities for damage such as chips and spalls. In addition, the owner may want to consider performance testing of mock-ups incorporating transitions at glazing systems and other materials, to evaluate the building envelope performance. By testing at the mock-up stage, corrective measures can be implemented inexpensively and systematically as required to improve the entire building performance prior to the actual building construction.

Sections 2.4.1 and 2.4.2 provide an overview on the topics of colour, texture and finish. Form liner patterns and textures can be found on form liner manufacturer’s websites to give the designers and owners a good idea of what can be achieved. A great deal of additional information, including photographs of sample colours and textures, can be found in the *CPCI Architectural Precast Concrete Colour and Texture Selection Guide* available by following this link. http://www.cpci.ca/en/resources/technical_publications/

2.4.1 Colour

Colour varies with aggregate colour and matrix colour, size of aggregate, finishing process and depth of aggregate exposure. As with most natural materials, colour variations do occur, and reasonable variations should be expected when specifications are written for the acceptance of architectural precast concrete. Colour variations will occur due to variations in quarrying, crushing, and screening of aggregates. Precast manufacturers control the curing conditions of the precast concrete in order to reduce the variations attributable to temperature and humidity variations in the plant. The precast manufacturer can assist the designer in the selection of shapes, colours and textures and finishes to minimize variations.

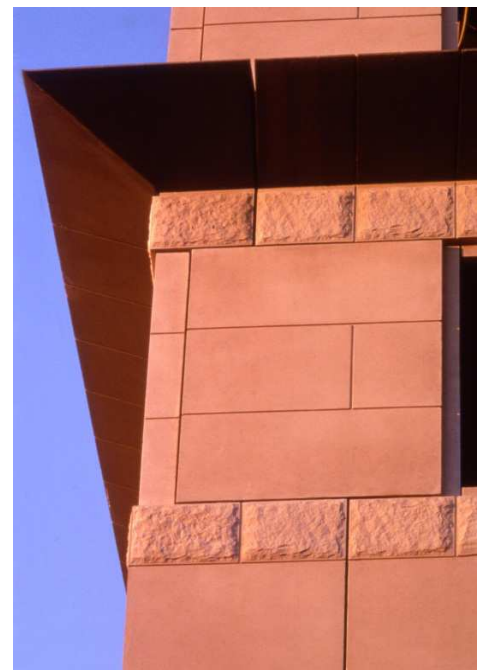

Pigments in the concrete mix can be used to replicate materials such as masonry. Source: CPCI



Surface applied stain can be used for interesting architectural effect. Source: M. E. Hachborn Engineering



Efflorescence on a precast concrete panel. Source: CPCI

Colour can also be introduced by using pigments to colour the concrete matrix to enhance the tone of the aggregates in the concrete mix or to duplicate the appearance of other materials.

Stains can also be used to colour the precast to give more vibrant colours or to create interesting colour combinations on buildings.

Colour and finish can sometimes be affected by efflorescence. Efflorescence is a white, powdery deposit that can form on the surface of all concrete and masonry products including brick, cast-in-place concrete and precast concrete. Efflorescence is typically caused by the migration of free soluble salts from within the masonry or concrete to the surface following periods of wetting and drying, and tends to be most visible at the beginning of the cladding's life and diminishes as the salts are bound and retained or washed away by natural rain. Efflorescence changes the surface aesthetics by leaving a temporary white "stain" on the surface. Possible methods to reduce the occurrence of efflorescence are presented in the *CPCI Architectural Precast Concrete Colour and Texture Selection Guide*. The guide also suggests ways to address efflorescence if it is already present.

2.4.2 Textures and Finishes

Textures can be created using form liners during casting, treatment of the concrete surface prior to hardening, or post-treatment of the concrete when the concrete has reached sufficient strength.

In general, the cost of texturing can be approximated as shown in Table 1.

Table 1. The relative cost of different texture treatments for architectural precast concrete wall panels

Lowest Cost		←	→	Highest Cost
<ul style="list-style-type: none"> • Smooth form finish 	<ul style="list-style-type: none"> • Exposed aggregates by using chemical retarders or water washing • Form liners • Sand or abrasive blasting 		<ul style="list-style-type: none"> • Exposed aggregates by acid etching • Hammered ribs • Fractured fins • Sand embedment 	<ul style="list-style-type: none"> • Honing or polishing • Thin brick or stone veneers • Tooling or bush hammering

2.4.2.1 Smooth as Cast

Smooth form finishes are amongst the most economical, but are not normally recommended as they accentuate minor surface imperfections. The following are considerations:

- Visible colour variations can occur with typical grey cements due to the difference in the cement itself.
- White cement can provide improved uniformity but at an additional cost.
- Flat, glossy, impermeable forms must not have any surface imperfections and must be constructed to avoid leakage of finishes which will show on the finished face.
- The uniformity of manufacturing procedures is critical, including cleaning of forms, application of release agent, concrete curing and concrete quality.
- Repair of smooth surfaces after casting is difficult and the results are often more noticeable if conducted after a period of weathering.



Smooth precast concrete panels coated with paint.
Source: CPCI

If a smooth finish is desired, painting or staining is recommended. Use the following approaches to reduce the aesthetic limitations of smooth concrete:

1. Create profiled surfaces,
2. Subdivide large panels into smaller areas with false joints, and
3. Introduce shadow effects, etc., through architectural details.

2.4.2.2 Exposed Aggregate

Chemical retarders, usually applied to the form surfaces, retard the hardening of the concrete matrix near the surface creating an exposed aggregate (or washed) surface. The surface layer of matrix is removed shortly after stripping from the form by brushing or pressure washing. This removes a portion of the cement paste between the coarse aggregate. Chemical retarders are available to achieve various depths of exposure, and are normally limited to a depth of 1/3 the size of the coarse aggregate.

2.4.2.3 Abrasive Blast (Sandblast) Finish

Abrasive blasting of surfaces generally creates three degrees of exposure:

1. Light abrasive blasting removes only the surface film of cement paste, exposing the edges of the coarse and fine aggregate closest to the surface. This creates the appearance of a small fleck (small specks of colour) in the paste colour.
2. Medium blasting removes additional cement paste, exposing equal areas of coarse aggregate fine aggregate and cement paste. This finish creates the appearance of a larger 'fleck' and a more pronounced colour contribution of the aggregate
3. Heavy blasting removes the cement paste such that the coarse aggregate is the dominant surface texture and colour.

While abrasive blasting can be used for any degree of exposure, it is generally only economical for light to medium aggregate exposure. The use of chemical retarders combined with abrasive blasting provides more economical medium or deep exposures.

Uniformity on blasted surfaces is more easily achieved with heavier abrasive blasting, whereas light abrasive blasting requires highly skilled operators and careful assessment of large panels to establish uniformity and avoid a patchy appearance.

Abrasive blasting removes the natural reflectance of aggregates resulting in a somewhat dull appearance of the concrete compared with panels finished with chemical retarders.



Precast panel where the aggregate has been exposed over a portion of the face by washing. Source: CPCI

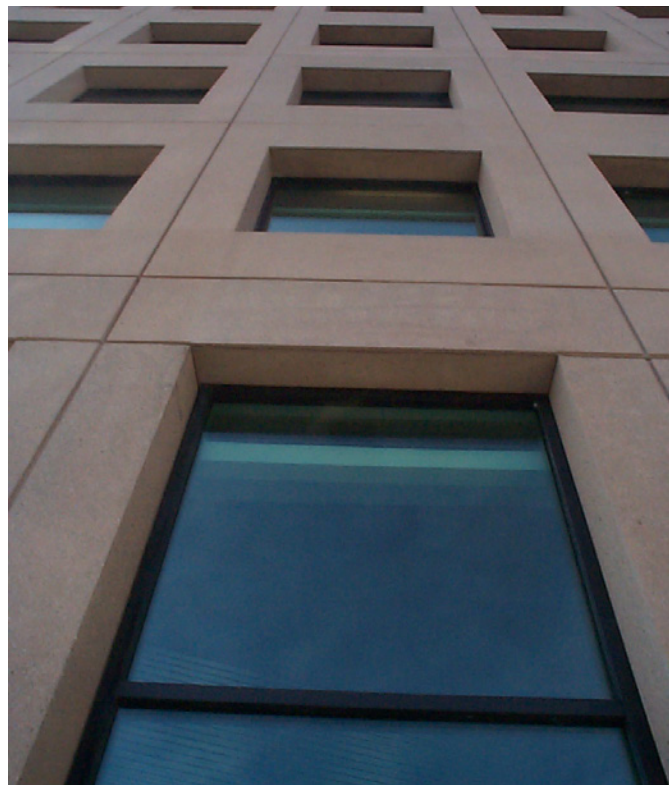

Precast panel with sandblasted finish. Source: CPCI

2.4.2.4 Acid Etching

Acid etching is often used for a light exposure. The process dissolves the surface cement paste, revealing primarily the sand portion of the paste fraction, and makes a small percentage of the coarse aggregate visible. Guiding principles include:

- Use only acid-resistant siliceous sand and aggregate such as quartz or granite. Other carbonate aggregate such as limestone, dolomite or marble may discolour and dissolve with exposure to hydrochloric acid.
- Best results are achieved if acid etching is conducted on concrete that has attained the design strength and is at a uniform temperature.
- Protect all metal surfaces from exposure to acid with plastic or coatings such as bituminous paints, vinyl chlorides or chlorinated rubber.
- Thoroughly flush panels with potable water after etching to stop the potential of future chloride ion penetration and to control efflorescence.

2.4.2.5 Bush Hammered Finish

Bush hammering uses power-driven steel chisels to distress the surface of the concrete. Bush hammering removes approximately 4 mm of hardened concrete and fractures the larger aggregates near the surface.

The technique is most suitable for flat or convex surfaces and for concretes containing aggregates such as limestone, dolomite, marble or calcite. Quartz and granite-based aggregate concrete mixes are not recommended for this application as they are difficult to bush hammer and may fracture into the surface rather than across the surface, leading to increased risk of water penetration.

It is important to increase the cover for reinforcing steel elements to 50 mm when bush hammering is to be used on any concrete surface.

If architectural features like ribs, fins or reveals are to be included with a bush hammered finish, it will be important to discuss the geometry of these elements with the precaster to determine what is economical and achievable.

In most cases the same appearance can be obtained more economically with a form liner and abrasive blasting of the panel after stripping.

2.4.2.6 Sand Embedment

This finish is used to create an exterior aesthetic that includes specific patterns or uneven materials on the surface of the precast panel. A layer of sand is placed inside the forms and the desired stones or other objects are pressed into the sand by hand before casting the concrete for the panel.

Where heavy exposure of stone facing material is desired, stones can be handset into a sand bed within the form to a depth that keeps the concrete 25 to 35 per cent of the stone diameter from the face.

It is important to consider aggregate density at panel edges and to consult with the precast manufacturer to determine what is feasible and achievable within the project budget.

2.4.3 Stone Veneered Precast Panels

Stone veneer-faced panels are fabricated by placing the veneer material face down in the form with the associated veneer anchorage up, followed by application of a bond breaker and placing of the backup concrete. Development for this design requires the close interaction of stone supplier, the engineer and architect, and the precast manufacturer. Often, to save on cost, a designer might choose to use stone veneer panels for the first two to four stories of a building and then emulate the stone veneer with sandblasting, etching or form liners for the remainder of the building's upper floors. The following should be kept in mind when developing a stone veneered precast panel design requirement:

- Coordination of stone purchasing including arrangements for colour samples, quarrying, transportation, cutting and finishing must often be established prior to tendering of the main construction project. Long lead times are required for international shipping of specialty materials.
- Stone anchorage to the panel is most often specified by the main design team engineer with detailed design completed by the precast engineer who is responsible for the shop drawings.
- Durability of stone veneer varies widely with stone type. The properties of the stone should be reviewed prior to acceptance for the project.
- The required thickness of stone veneer varies widely with the properties of the stone and the anchorage design. Generally, the minimum thickness is 30 mm for granite and 50 mm for marble and limestone.
- Bond breakers can be 2 mil to 10 mil polyethylene sheet or 1 mm to 6 mm closed cell polyethylene foam. The latter provides movement capability when in service, although stone breakage can be a concern during transportation to the jobsite unless special care is taken to accommodate transportation loads.
- Stone anchorage is most often provided using stainless steel hairpin (Omega (Ω)) clips or cross-stitch dowels. These anchorage devices should be supplied with 2 mm thick polyethylene sleeves to allow for expansion and contraction of the stone veneer relative to the concrete.

2.4.4 Clay Product Faced Precast (Brick, Tile and Terra Cotta)

Facing precast concrete wall panels with clay-based products can provide many advantages:

- Plant production of the masonry-faced elements avoids the normal job-site challenges associated with typical masonry construction, including temperature and moisture control.
- Site batching of mortar is not required

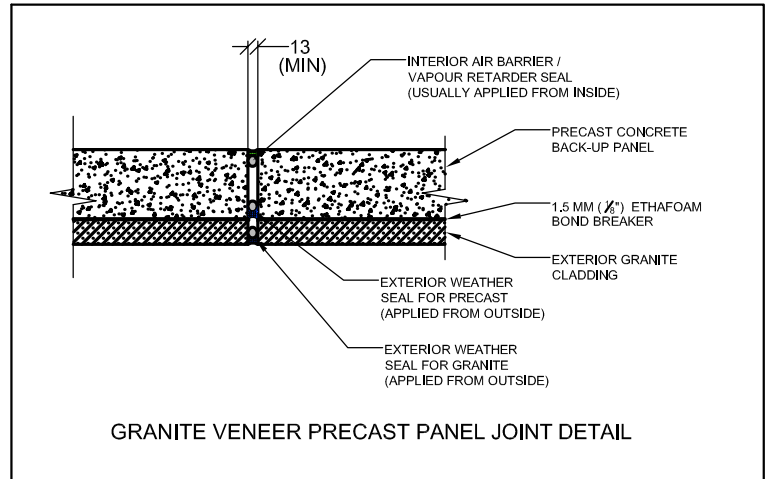

Figure 2-8: Granite veneer concept. Source: CPCI:



Omega clip. Source: M. E. Hachborn Engineering



Omega clip in granite. Source: M. E. Hachborn Engineering



Photo Caption: Granite veneer precast panels. Source: CPCI

- Curing times are controlled more consistently in the precast plant.
- The impacts of exterior weather conditions are eliminated and are replaced by controlled batching, manufacturing, and curing processes.
- There is no need for the long on-site construction schedules required for typical masonry construction, or the additional site costs for scaffolding, hoarding, heating or lift platform rentals.

When facing concrete panels with thin masonry products, special attention should be given to assess the bond between the clay products and precast concrete. This includes design provisions to limit panel bowing that may affect the bond while the panel is in service. The re-absorption of water by the masonry products coupled with the prevention of surface drying on the face of the concrete in the panel due to the clay products and the surface drying of the concrete on the back of the panel may introduce significant bowing of the panels prior to placement on the building. Care must also be exercised when choosing dark colours due to the thermal absorption of the facing which will add to thermal bowing of the panels. Strategies to mitigate these potential problems are outlined below.

The following considerations should be included in any design using clay products as facer materials:

Bond

- Select face units 13 mm to 20 mm thick with the back of the unit scored or keyed to improve bond.
- Face units with a high initial rate of absorption (IRA greater than 1 gram per minute per square inch) should be soaked in water prior to placement.
- Clay products are subject to expansion due to re-absorption of water following removal from the kiln, whereas concrete undergoes shrinkage during the early stages of curing. Generally the bond between concrete and clay masonry adequately overcomes these strains for panels up to 9 m in length.

Aesthetics

- Bricks must be dimensionally accurate (+0, -3 mm or better) for use with typical pre-formed placement grids.

Panel Bowing

Material properties of clay product facings and concrete panels are significantly different and can contribute to panel bowing. The designer and precaster need to consider the following:

- Colour of the facing material, as dark clay faced veneers absorb heat from sun exposure and can contribute to significant thermal bowing, especially on southern and western exposures.
- Interior-to-exterior temperature differentials across the panel.



Masonry elements being placed in the rubber form liner, prior to concrete placement in the precast plant. Source: M. E. Hachborn Engineering



Brick-faced precast panels. Source: M. E. Hachborn Engineering

- Coefficients of thermal and moisture expansion of the materials.
- Differential shrinkage of the concrete and expansion of the facing are usually not a problem when clay products are aged at normal outdoor humidity for two to four months after manufacturing.
- Ratio of cross sectional area of the materials and their respective modulus of elasticity.
- The reinforcement type, location and amount.
- Use of prestressing.
- The type and location of connections to the structure.

2.4.5 Form Liners

A wide variety of materials can be used as form liners to create a wide assortment of appearances, including simulated wood, textured or striated panels, or bush hammered concrete. The precast manufacturer should be consulted for techniques to accommodate different absorption of the concrete mix water due to the form liner, and to ensure the liner design allows easy stripping of the panel from the form. Panel sizes and available liner sizes also need to be considered to minimize form liner joint lines. Efficient panelization of the project is a must and the drawings must be reviewed carefully and quickly to minimize the amount of form liner required. Form liners may be used on the whole panel or be limited to portions of the panel surface.



Form liners provide options for colour and texture.
Source: M. E. Hachborn Engineering



Form liners can be used to create interesting visual effects. Source: M. E. Hachborn Engineering

CHAPTER 3 Manufacturing, Transportation and Installation

3.1 Manufacturing, Materials and Quality Control

3.1.1 Precast Concrete Panel Manufacturing

Most precast architectural panels are manufactured using wood moulds or forms. Forms are coated with resin that is often reinforced with fibre glass cloth. A well designed and maintained wood form can be used to cast 20 to 40 similar panels if constructed and prepared properly.

3.1.2 Form Configurations

Form configuration and materials vary by precast manufacturer and with the complexity of the project. The most cost efficient method of production for the precaster (and hence the owner) is to ensure that the cost of facilities and form fabrication are distributed over many production units. This imposes a discipline of creating repetition in the design of the building facade. Variations of the original common element are possible but the relationship to the master form should be maintained to achieve the maximum reuse of the form. Examples of the use of the master form can be seen on many buildings with repetitive spandrel shapes or window panel units dominant on the building elevations.

The aim of repetition in the design is to reduce costs by increasing plant productivity. Repetition means fewer forms and a subsequent reduction in form construction costs. Production-line manufacturing can be implemented in the plant when a particular casting sequence is repeated each day, leading to improvements in efficiency through the repeated operations of familiar tasks. Handling, storage and delivery are also simplified with subsequent reductions in the risk of errors. Site efficiency is also improved through the repetition of familiar erection sequences. These benefits can



Manufacture of custom wood form used to make precast panels.

Source: M. E. Hachborn Engineering

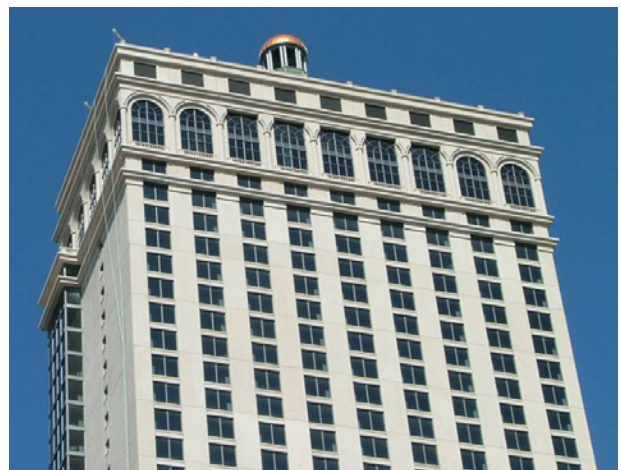

Hilton, Niagara.

Source: M. E. Hachborn Engineering

only be achieved if there is a high degree of repetition in the design and production of the precast elements.

Often, in the initial design stage, a high degree of repetition appears possible; however, as the design details are finalized, very strict discipline is required by the designer to avoid the creation of a large number of non-repetitive elements. Any budget costs given at the initial design stage should consider the possibility that the number of non-repetitive elements may increase as the design progresses. If non-repetitive units are unavoidable, the increase in costs can be minimized when the elements can be cast from a master form with simple modifications. This eliminates the need for completely new forms. In general, it is easier to alter a form if the variations can be contained within the total form envelope. This can be accomplished through the use of bulkheads or block outs. Cutting into the form surface should be avoided if possible, and done only as a last resort.

Master Forms

A Master Form can be developed that includes the ability to accept minor changes such that variations in the appearance of each panel can be easily accommodated. Alternate panel shapes can be provided through pre-engineered modifications to the Master Form. Panels are normally produced from largest to smallest to minimize damage to the form surfaces.

Conventional and Wedge Up Forms

Conventional Forms employ removable bulkheads at the perimeter to allow removal of the panel. These forms allow flexibility but reassembly, realignment and checking is required prior to each casting.

“Wedge Up Forms” employ removeable bulkheads at the perimeter to allow for removal of the panel similar to conventional forms but the bulkheads are placed against a base to ensure the panel size, and alignment remain the same. These bulkheads are then held in place with wedges driven between the bulkhead outer edge and

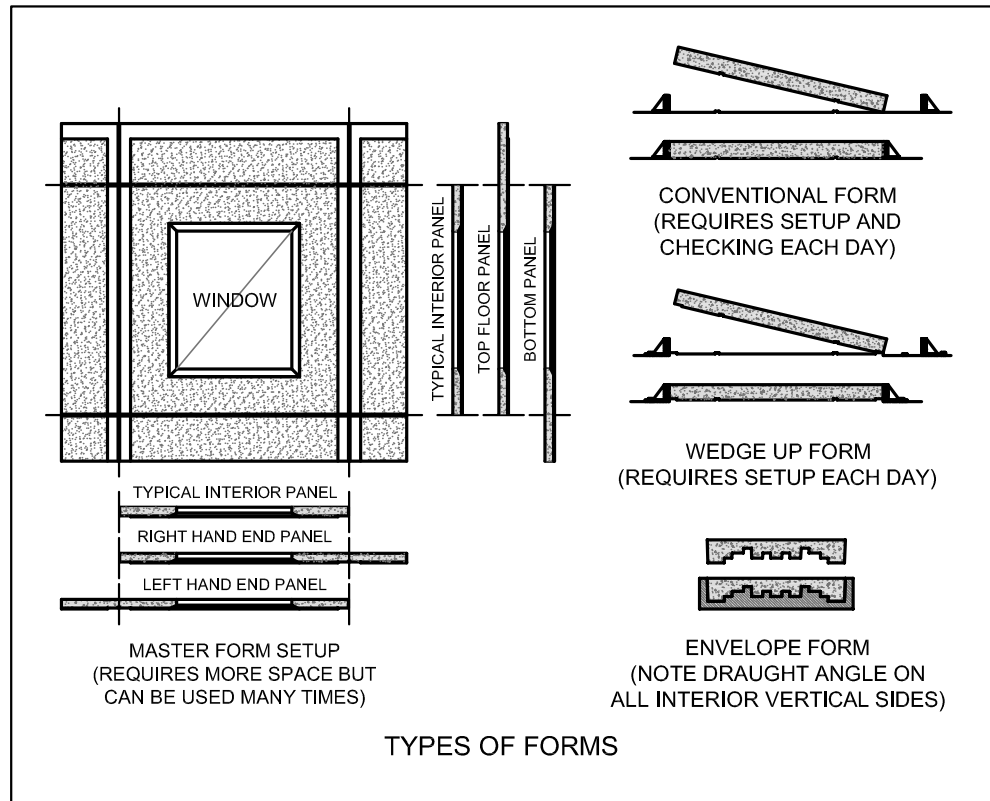

Figure 3-1: Form types. Source: M. E. Hachborn Engineering



Manufacturing with a conventional form. Source: CPCI

blocks placed strategically around the perimeter. These forms are good for repetitious panels but still require some degree of reassembly and checking.

Envelope Forms

Envelope forms are box forms with all sides remaining in place during casting and stripping. Set-up cost is higher and this approach is not normally considered economically feasible unless a minimum of 25-30 units are required. The appropriate draft angle is required to allow for stripping and will result in slightly wider panel-to-panel joints at the face of the panels. The precast manufacturer should be consulted.



Combination of Envelope and Conventional Form (Only One Side is Removed for Stripping). Source: CPCI

3.1.3 Materials

The design team must define the performance characteristics of the various elements within the precast panel assembly and select the desired finished appearance. Final concrete mix design should be left to the precast manufacturer in keeping with national standards, good engineering practice, specific structural and environmental loads expected, and the local climate where the panels are to be in service.

Where possible, the designer should work with the precast manufacturer to ensure the performance expectations and capabilities of the materials are properly integrated into the aesthetic design and cost balance of the project. This includes:

1. Concrete mix design,
2. Concrete admixtures,
3. Grout and Mortars,
4. Reinforcement, and
5. Anchor materials and design.

The *CPCI Design Manual* provides information on these considerations.

3.1.4 Precast Concrete Panel Manufacturer Certification

A unique requirement of precast concrete manufactured for use in Canada is that it must be certified according to CSA 23.4. This is a legal requirement of the building code and must be adhered to.

Quality audits are an integral part of the CPCI Precast Concrete Certification Program for Structural, Architectural and Specialty Precast Concrete Products and Production Processes. Audits ensure the CPCI member precast manufacturers have a quality system in place that is consistently adhered to, reflects national standards, and that the additional unique program requirements are achieved. Audits evaluate and identify areas requiring upgrading or corrective action (continual improvement). There are a minimum of two audits in each full calendar year for a precast manufacturer with ongoing participation; each audit is performed by a professional engineer and is for two full days. The purpose of the audits is to:

1. Determine the degree of conformity of the manufacturer's quality system and the finished products with the specified requirements.
2. Determine the effectiveness of the implemented quality system in meeting specified quality objectives.
3. Provide the Manufacturer with an opportunity to improve their quality system.

4. Confirm that the Manufacturer meets the requirements of the national standards.

Adherence to the CPCI Precast Concrete Certification Program is monitored by an Accredited Certification Organization (ACO) that is responsible to conduct quality audits in a fair and objective manner with equal treatment of all precast concrete manufacturers. Auditors are professional engineers, knowledgeable and trained in the evaluation of precast concrete manufacturing plants and procedures. The ACO, using a detailed audit system, determines a grade for each Division of the CPCI Audit Manual, a grade for each Product Group and an Overall Plant Grade. A passing grade for Certification in each Product Group is a minimum of 80 and a minimum of 70 for any one Division. The CPCI Precast Certification Program is unique in Canada in that plants are audited to the more stringent requirements of both CSA A23.4 and the U.S. requirements of PCI MNL 116 and 117, on a clause by clause basis.

The CPCI Precast Concrete Certification Program is governed by a Quality Assurance Council (QAC), a third-party multi-disciplinary body that oversees the implementation of the program. The Accredited Certification Organization (ACO) is responsible to the Quality Assurance Council which plans, formulates, oversees and reviews the CPCI Precast Concrete Certification Program by:

1. Establishing auditing criteria and grading standards,
2. Providing administrative review to ensure that policies and procedures are administered uniformly and are followed by all manufacturers,
3. Developing, reviewing and approving all information related to the CPCI Precast Concrete Certification Program,
4. Initiating and overseeing Accredited Certification Organization policies and manuals, and
5. Issuing special advisories to clarify standards or to add to the requirements in the standards.

More information and instructions on the process can be found at www.precastcertification.ca

How to specify CPCI Certification

1. Precast concrete manufacturers to be certified to Canadian Precast/Prestressed Concrete Institute (CPCI) Plant Certification Program in [Architectural Precast Concrete Products, A1,] [Subcategory AT], [Precast and Prestressed Bridge Products, B,] [Subcategory] [B1] [BA1] [B2] [BA2] [B3] [BA3] [B4] [BA4] [Commercial Precast and Prestressed Concrete Products (Structural), C,] [Subcategory] [C1] [CA1] [C2] [CA2] [C3] [CA3] [C4] [CA4] [Precast Concrete Drainage Products, D,] [Subcategory] [D1] [Standard Products, S] prior to the time of bid.
2. Only precast elements fabricated under the CPCI plant certification program to be acceptable, and plant certification is to be maintained for the duration of fabrication, [erection,] and until warranty expires.
3. Precast fabrication to meet the requirements of CAN/CSA-A23.4-16, including Annexes A and B, together with PCI MNL-116 and 117 and CPCI certification requirements.
4. Note: Visit http://www.precastcertification.ca/en/certified_plants/product_groups/ for the CSA A23.4 category descriptions, and to view the most current list of CPCI certified plants.

3.2 Transportation and Installation

3.2.1 Precast Panel Transportation from Plant to Site

Transportation of the precast panels may be the deciding factor when determining panel sizes for a structure. The size of panels should be kept as large as possible to reduce erection costs and the number of panel joints. Panel sizes up to 3.7 m x 12 m are typically accommodated by most hauling and handling equipment. Considerations include:

1. Types of trailers,
2. Types of frames,
3. Supporting material, and
4. Transportation limitations for weight, width and height. (Load limits, seasonal load limits, overhead clearances, width restrictions, trailer capacity, height, width, distance from project site, and condition of roads to the site all influence panel size limits).

For further detailed information on methods, materials and equipment used in handling and transporting all types of precast concrete units, consult your local CPCI member precast concrete manufacturers.



Transportation of precast panels.
Source: Numesh Inc.



Lifting precast panel from transportation truck.
Source: Numesh Inc.

3.2.2 Installation Techniques

3.2.2.1 Precast Concrete Panel Installation

Erection of precast panels can be by the precaster, an erection subcontractor, or the building general contractor, depending on the project and the particular construction team involved. Normally the precast engineer designs lifting devices and checks stresses during handling.

The drawings or specifications should note any structural limitations of the building frame with respect to precast erection. The design objectives that apply to the design of each individual precast element should be consistent with the objectives of the complete project, of which the architectural precast concrete is a part. Structural integrity of the completed structure is the primary objective. Deflections must be limited to acceptable values, and stresses limited to prevent instability, reduced service life or premature failure of an individual element or the structure as a whole.



Installation of precast single wythe wall panels.
Source: CPCI



Erection of a precast panel using a tower crane.
Source: CPCI



Erection of a precast panel using a mobile crane.
Source: CPCI



Storage of precast panels in yard.
Source: M. E. Hachborn Engineering



Storage of precast panels on site. Source: CPCI

Limitations may be necessary to balance loads by elevation, to require rigidity of shear walls or to make sure that the schedule allows for the effects of concrete frame shortening due to shrinkage and creep.

The designer must clearly envision the erection process to utilize architectural precast concrete successfully. The following are some of the fundamental requirements for consideration:

1. Ensure unimpeded site access to accommodate continuous erection.
2. Provide a working area and adequate storage space.
3. Allow for a staging area for trailers and cranes.
4. Consider the types and capacities of erection equipment in relation to unit weights and sizes.
5. Allow for the lifting, turning, rotating and tilting of units, at the pickup point, the final location on the structure and any temporary location in between.

6. Provide layout points for the survey of the structural frame, the location of cast-in hardware and the final position of the precast on the structure.
7. Consider the erection requirements of panels left off to accommodate the construction man-hoist.

It is critical that the capacity of locally available erection equipment be considered when sizing precast panels. Tower crane capacities of 10,000 kg are common in most urban locations. Panel sizes should be maximized in accordance with crane capacities.

Speed of erection and economy are directly related to crane type and size, panel size, type of connections and the arrangement of the building frame. Connections should allow for initial setting of the panel, release of the crane and final alignment of the panels that is completed independently of crane support. Mobile cranes may provide more flexibility and accommodate larger panel sizes. Reach and crane access conditions must be carefully reviewed.

3.2.3 Connections

Critical to the successful application of architectural precast concrete panels in construction is the design of the anchorage connections which attach the precast wall panels to the building frame. Typically, the engineering consultant does this in concert with the precast fabricator, precast engineer and precast erector.

Connections of architectural precast concrete wall panels to the building must provide adequate anchorage to resist gravity, wind and seismic loads. At the same time, the connections must also allow for horizontal and vertical adjustment to account for construction tolerances, final alignment of the panels during erection and sliding capabilities where they are designed to allow for seismic, thermal, and/or shrinkage movements. Connections must also be designed to minimize thermal bridging and to avoid penetrations of air and vapour barriers. Most precast concrete wall panel anchoring systems involve one or more of the following connection types:

- *Direct Bearing (Gravity):* Direct-bearing connections transfer gravity loads to the supporting building structure or foundation. They are also used where panels are stacked and self-supporting for vertical loads, and may include horizontal lateral tie-back connections to resist lateral forces.
- *Shims:* Shims are occasionally used to align panel edges. Care must be taken to avoid crushing of shims or staining that may result from shim corrosion/degradation. Plastic (Korolath) shims can be used to eliminate the corrosion concerns.

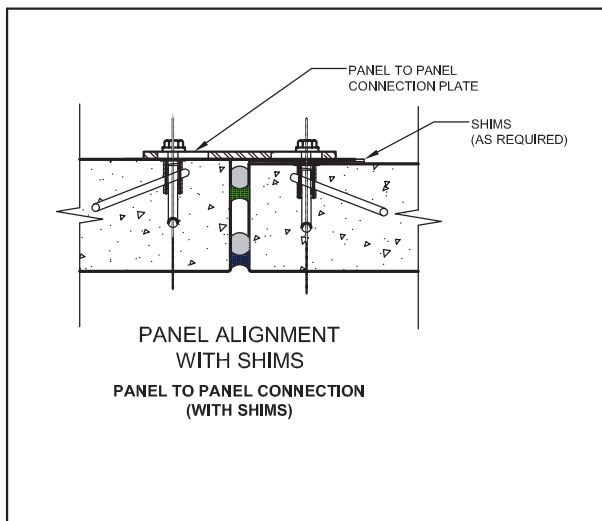

Figure 3-2: Detail of Sealant and Shim placement.
Source: M. E. Hachborn Engineering



Shim placement for aligning panels.
Source: M. E. Hachborn Engineering



Eccentric (indicated by arrows) and lateral load connections. Source: Morrison Hershfield



Eccentric lateral load connection. Source: Morrison Hershfield



Lateral tie anchors. Source: Morrison Hershfield



Lateral tie anchors. Source: Morrison Hershfield

- *Eccentric Bearing (Gravity):* Eccentric bearing connections are needed above the first support level when movements of the support system are possible. Eccentric connections may be created by reinforced concrete corbels, cast in steel shapes or steel shapes welded to embedded plates after casting.
- *Lateral tie-back:* Lateral tie-back connections restrain the panel in the required position and resist wind and seismic loads perpendicular to the panel only. They do not carry vertical loads like gravity load. It is advantageous to have adjustment in these connections as panel alignment may need to be modified once other panels are installed.
- *Seismic connection:* Seismic connection design can be incorporated into one or more of the gravity or lateral connections. Additional connections may be required and can be added as required.



Panel to panel alignment and lateral load connections.
Source: Morrison Hershfield



Lifting Loop (arrow)
Source: M. E. Hachborn Engineering

- One or more degrees of freedom for movement in connections may allow for thermal and shrinkage movement within panels.
- *Panel Alignment*: Some connectors are used for panel alignment with respect to adjacent building assemblies and may or may not transfer design loads.
- *Lifting / Transportation / Installation Hardware*: Hardware is also provided on precast wall panels to assist with:
 1. transferring the panels from the precast manufacturers plant to the storage yard,
 2. placing the panels on the transportation trailer, and
 3. lifting the panels from transportation trailer onto the building.

These devices range from the simplest form of a looped braided steel cable inset into the precast panel to any number of proprietary lifting hardware, each with their own specific advantages. Each precast manufacturer has a preferred system and it is up to the precast manufacturer to use the one best suited for the project.

An individual panel will typically require a minimum of six connections:

- two gravity connections (eccentric or direct bearing), normally located at the same elevation near columns in multi-level building frames, and
- a minimum of four lateral load tie-backs. In some instances the gravity connections can accommodate lateral loads in addition to the gravity loads with minimal additional cost, thereby reducing the number of separate connections by two.

The need for more connections is determined by the precast manufacturer's engineer, and considers the panel articulation, the panel loads and the connection capacities. In some instances, additional connections are required to maintain the panel alignment or to reduce bowing.

The design and the location of connections can have a significant impact on the structure as a whole, and the performance of the building envelope. They may also contribute to the success of the project as they affect the ease and speed of erection. The designer should provide sufficient space for the precast panel connections. It is preferable to locate the load bearing connections close to columns to avoid the effect slab deflection has on the precast panel alignment. Lateral connections are normally connected to columns, floor beams or floor slabs.

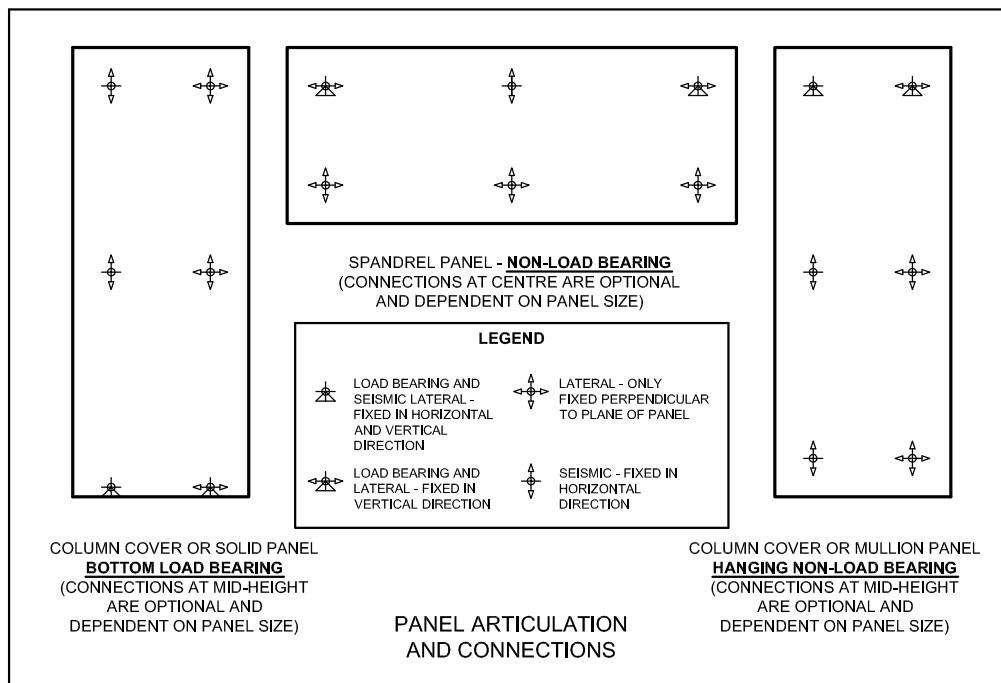

Figure 3-3: Panel Articulation. Source: M. E. Hachborn Engineering

Additional considerations:

- Locate connections for ease of access during installation. For example, locate connections above floor slabs, not below, to allow faster and better access to the connections.
- The use of grout, dry-pack or epoxies in connections is often not considered reliable and should be avoided whenever possible. Special provisions must also be made in cold weather with these types of connections. The verification of this type of connection by the design engineer is very difficult. When shims are used for load bearing, care must be taken to ensure the shims are not overloaded and crushed and that corrosion and the resulting staining of the panels does not occur.
- Keep connection hardware consistent throughout the project where possible. Greater capacities than the minimum required will maintain hardware size and bolt torque requirements (for mechanical connections) across the entire project. This simplifies panel design, drawings, production, and installation and connection verification. Larger sizes will also accommodate minor changes and any unexpected damage that may occur during handling.
- Use temporary shims in joints of non-load-bearing panels to establish panel spacing as required during erection. Removal of these temporary shims is important before project completion to ensure the proper articulation of the panels and to allow sealants to be applied as designed. It is critical that the shims used for alignment purposes do not transfer loads from one panel to the next unless the panel connections have been designed for these loads.
- Design connections to reduce penetration of the air and moisture barriers, and thermal insulation. This requires considerable planning and careful detailing. The installation of precast panels after the installation of a back-up wall is not recommended and usually results in significant cost implications and performance problems. The logical sequencing of construction is a must to ensure continuity of the air and moisture barrier, and thermal insulation, particularly around the connections.

Steel anchor materials include plain black steel, zinc-rich paint coated steel, zinc plated steel, hot-dipped galvanized steel or stainless steel. The choice depends on the expected degree of exposure to corrosive elements while in service, and the required design life of the structure. The connection design may have varying degrees of complexity to provide for construction tolerances and adjustment in both the horizontal and vertical axes as well as in and out of the plane of the panel.

Design connections to resist or avoid corrosion. This is especially important for connections that rely on welding of steel elements, as weld locations can affect the corrosion resistance of steel materials and can nullify the benefits of zinc galvanizing. As a minimum, zinc plating or hot-dip galvanizing is recommended, with zinc-rich paint touch-ups of any chipped coating or field-cut components. If connections are expected to have long term moisture exposure, more rigorous corrosion protection may be necessary, such as the use of stainless steel connection hardware.

The anchorage system must be compatible with the type of building frame and the anticipated exposure conditions. Connect to or near the columns wherever possible. Concrete frames require hardware to be cast into the frame to receive the panels. Steel frames may require larger beam sizes and stiffening at the precast connections as well as additional adjustment capability in the connection hardware to account for frame deflection and rotation as the precast is attached. The specifications should indicate who supplies and installs these frame elements. Brackets may be required for large offsets of panels from the building frame or building face. Seismic requirements can play a significant role in the anchorage design. It is usually beneficial for both the precast manufacturer and the steel fabricator to meet prior to the completion of precast and steel shop drawings in order to ensure all connection hardware is located appropriately and steel member sizes are adequate to carry the precast loads.

CHAPTER 4 Performance Criteria

Architectural precast concrete wall assemblies are designed to provide effective control of air infiltration and moisture penetration through the building envelope while at the same time providing the aesthetic appeal desired by the architect and the owner. With the proper understanding of building science, particularly the use of insulation and the treatment of joints between interfacing materials, an efficient design can be achieved. Good detailing and proper construction of the components in these assemblies will enhance the integrity of the entire building envelope, and reduce the potential for future problems. Choosing the best products available will reduce maintenance costs during the life of the structure and provide an efficient, long term sustainable solution.

To ensure continuity of thermal insulation, air barriers and vapour retarders, it is important to treat the envelope as a complete assembly, specifically the interface between adjacent materials and components such as foundation, wall assemblies, windows, and roof. The key is to understand the physical properties of each material, to optimize its performance, and use building science principles to ensure that the interaction with adjacent materials does not adversely affect the overall goal as part of the building envelope. It is helpful to identify each component in each material assembly and follow these components, one by one, from one assembly to the next.

Without proper integration of all components, the weather tightness of the enclosure may be compromised. Consideration of the climatic conditions outside the envelope, as well as the activities that may take place within the interior space of any building, are paramount.

4.1 Building Science

The building envelope is the environmental separator between spaces of different environmental characteristics. Most often this is the separation between the exterior unconditioned environment and interior conditioned spaces. This includes the walls, glazing systems, roof and foundation, and it is only through the understanding of how all these components interact and work that a successful building envelope can be achieved.

Well-designed building envelope assemblies use proven and tested building science concepts to ensure performance. In Canadian Building Digest CBD-48 *Requirements for Exterior Walls*, Neil Hutcheon outlined the following basic performance requirements for exterior walls:

1. Control of heat flow
2. Control of air flow
3. Control of water vapour transmission
4. Control of rain and snow penetration
5. Control of light, solar and other radiation
6. Control of noise

7. Control of fire
8. Provision for strength and rigidity
9. Durability
10. Aesthetic appeal
11. Economy

As outlined in the National Building Code of Canada, the environmental separation requirements – control of heat, air, water vapour, precipitation, and noise – depends on the loads that are imposed by the location and the intended functions within the building. Minimum acceptable performance for health and safety is also set by applicable building codes. These performance requirements will influence the selection of panel type and design details, and the precast manufacturer's engineer and the building's design team should work together to develop the appropriate design details.

Sustainability and the environmental impact of building materials and systems and their manufacturing and transportation processes are also important considerations. (See Section 4.13).

Other important issues that need to be considered by the building designer to facilitate the expected building envelope performance include;

- Materials that will perform for the expected design service life of the building (This includes all components of the precast concrete mix design.),
- Efficient operation of a building once commissioned,
- Careful use of energy resources (energy efficiency), and
- Required maintenance of the building envelope components to ensure all components continue to perform as originally designed.

4.2 Structural Considerations

The structural design of architectural precast panels must consider the performance characteristics of the individual precast panels, the building support system (beams, columns, slab, etc.), and the connections between these two.

The building structural frame must provide sufficient support to the precast panels to resist both lateral and vertical forces. The deflection of concrete versus steel frames under short-and long-term loading can vary significantly and it is vital that the design of the panels and panel connections to the building frame respect the anticipated behavior of the building frame under the various loads. (See Section 3.2.3)

4.2.1 Cast-in-place Concrete Building Frame

All concrete structural frames undergo drying shrinkage over time, which is the shortening of structural elements, because of the hydration process and drying of the cement matrix. The shortening of the concrete frame will occur at different rates dependent on age (duration of curing) and environment. This phenomenon will induce forces at the lateral connections unless the connections are designed to accommodate some movement of the panel relative to the frame.

Another dimensional change in concrete frames occurs as a result of creep deflection and creep shortening. Creep in concrete occurs as a result of sustained loading over time and varies with the age and strength of the concrete at the time of loading. These changes can introduce significant movements and forces on exterior wall components. Creep deflection is a factor with precast panels that are connected to concrete frames at the exterior horizontal slabs or beams. Connections, joint location and joint design must accommodate the anticipated long-term creep. Locating connections near columns will minimize these problems.

Creep shortening is cumulative (floor-to-floor) and is most significant in high-rise concrete frames. When not accommodated within the cladding attachment system, it can cause closing of horizontal joints and potential compression failure and spalling of exterior precast panels. Connection design and calculation of joint size must recognize the effect of creep shortening.

The building designer must collaborate with the structural design engineer to determine the expected concrete frame shortening from shrinkage and creep such that this adjustment can be accommodated within the cladding joint and anchorage system.

4.2.2 Precast Concrete Building Frame

Precast concrete structural frames are subject to the same general effects of load deflection and creep as cast-in-place frames. However, creep is generally less of a concern with precast concrete frames compared with cast-in-place concrete, since the precast elements of the structural frame are installed and placed under design load after the precast concrete has reached a higher percentage of its ultimate strength and after the precast concrete has cured to a large degree. The behaviour of precast frames and the cumulative effects of gravity loads and creep will be different depending on the connections between elements and the number of joints.

If a precast concrete structural frame is being used, then the building designer should coordinate calculation of the expected structural frame movements with the precast manufacturer to ensure that the expected movements can be accommodated by other building elements, for example HVAC systems or other cladding materials.

4.2.3 Steel Building Frame

Steel building frames do not undergo shrinkage or creep. Structural steel will expand or contract due to changes in environmental temperature, so it is common for structural frames in Canada to remain on the interior of the building.

Steel frames are inherently lighter and undergo deflection and torsion rotation more readily than typically stiffer concrete frames. This characteristic will have an impact on the design of connections, joints and sizing of the architectural precast elements to be supported. Locating load bearing connections at or near columns will minimize problems with deflection of steel spandrel beams.

The building designer must coordinate with the structural designer to identify expected frame movements under design conditions such that these movements can be accommodated in the design of the architectural precast panel connections and joint design.

4.2.4 Hybrid Building Frame

A hybrid building frame is defined as a structural frame that uses at least two different construction materials to form the complete structural frame.

In some hybrid systems, the non-load bearing precast elements serve as cladding solely designed to withstand lateral wind forces, seismic forces, and their own dead load. All of these loads are transferred laterally to the adjacent primary building structural frame through the precast connections.

Some hybrid precast panel cladding systems are load bearing (self-supporting for vertical loads) but still transfer the lateral loads back to the primary building structure, for example steel, concrete, precast or other structural frame.

Some frame designs use the exterior precast elements as a component of the primary building structural frame, with the precast cladding also serving to transfer vertical loads to the foundations. Load bearing panels resist and transfer vertical and transverse loads applied from other structural elements, and cannot be removed without impacting the structural integrity of the building structure.

Regardless of which approach is being used, it is the building designer's responsibility to coordinate the structural design to ensure proper accommodation of all loads and load paths within the main building structural system. For precast elements that form part of these structural systems, the designer is encouraged to work together with the precast manufacturer and the precast engineer as early as possible in the design of the building such that the performance capabilities of the precast elements can be properly integrated and optimized into the overall design.

4.2.5 Structural Design of Panel Connections

The connections for load bearing panels are subject to larger and different loading than non-load bearing panels. Load-bearing precast panels not only accommodate the same loads as non-load bearing precast panels but they must also accommodate the primary structural loads like roof and floor, seismic, and possibly earth pressure loads. The panel connections must also accommodate volume changes due to shrinkage, creep and temperature variations, and may also be required to withstand blast loads, depending upon the design requirements. Chapter 4 of the *CPCI Design Manual* provides design information and illustrations for vertical and horizontal joint connections for load bearing panels.

For non-load bearing panels, deformations of the building structure may induce unintended loading of the precast panels, causing deflection and potentially moment and torsion loads. Common factors include:

- The weight of the precast elements,
- Volumetric changes of the supporting structure, and/or
- Torsion of the spandrel beams.

Lateral translation of the structural frame can also result in diagonal tension within panels if they are restrained. Lateral translation may also create interferences between panels if connected at different levels or to different structural members, limiting movement and creating unintended loads.

The panel connections must be designed and installed to permit unrestrained deformation. Illustrated examples of these conditions can also be found in Chapter 5 of the *CPCI Design Manual*.

The design of connections and horizontal joint widths of non-load bearing precast panels located at the base of buildings needs to consider column shortening (creep) of concrete columns, particularly if the precast element is rigidly connected at its base.

Non-load bearing precast panels containing openings may develop stress concentrations at the corners of these openings due to unintended loading or restrained bowing. The designer should avoid imposed restraints such that the loads are properly distributed across the panels and back into the primary structure.

Finally, the loads imposed in the movement of panels from forms-to-storage, storage-to-transportation, and from transportation-to-installation must all be accommodated in the connections intended to manage these loads. The use of temporary connectors for these purposes is common, with some being abandoned within the panels once installed on the building.



Gravity (vertical) load and lateral load connection, and lifting loop. Source: Morrison Hershfield

4.2.6 Structural Design of Precast Concrete Panels

The design of architectural precast wall panels requires consideration of the effects of the various loads that the panels will be subjected. Considerations include, but are not limited to:

- Manufacturing and construction stresses such as those incurred during stripping, handling, transportation and erection,
- Strain gradients across the thickness of the panel due to thermal and moisture differentials, during curing, and when the panel is restrained from bowing in service,
- Stresses in panels and their connections due to restrained volume changes and distortion of the building frame.
- Deflection of precast elements due to dead and live loads, wind and seismic loads and thermal loads,
- Tolerances for the support structure and for the fabrication and erection of precast panels, and
- Acceptable crack locations and crack widths.

The design of non-load bearing panels will be governed by the need to limit cracking. Since the precast panel is to provide the primary resistance to water penetration, cracking must be limited. Panel pre-stressing can be used to control cracking. Prestressing is achieved by pre-tensioning or post-tensioning in such a way that out-of-plane deformations are minimized. Thin panels (75 mm to 100 mm thick) can be prestressed eccentrically to counteract the tendency for bowing. It is very important that the prestressing of panels be incorporated into the overall panel structural design such that the resulting induced stresses are properly accommodated and provisions are made to address the loads. In some cases, transverse reinforcement may be necessary to counteract potential longitudinal splitting loads. The structural design of non-load bearing panels is covered in Chapter 3 of the *CPCI Design Manual*.

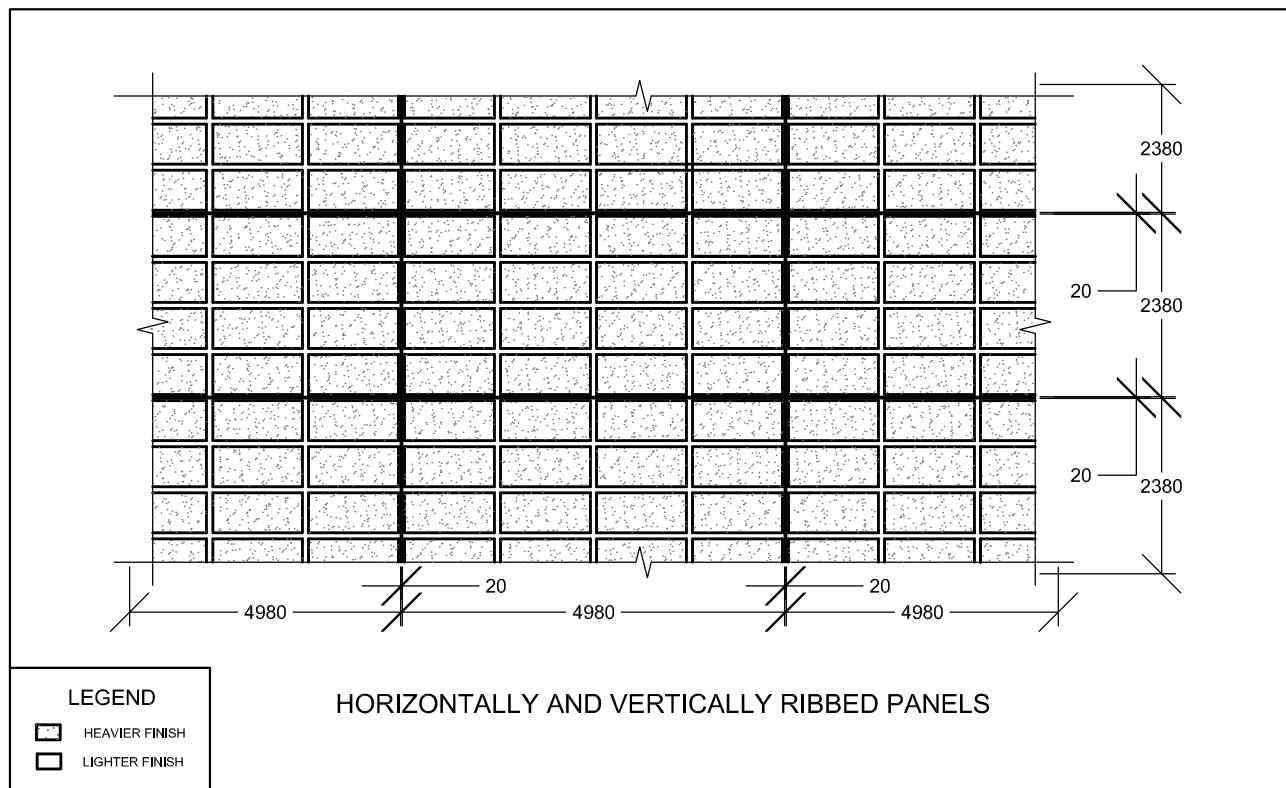

Figure 4-1: Horizontally and vertically ribbed precast concrete panels. Source: M. E. Hachborn Engineering



Multi-unit residential precast cladding.
Source: M. E. Hachborn Engineering



Precast wall alignment.
Source: M. E. Hachborn Engineering

Load bearing panels can be classified as flat or ribbed; both options can have window, door or other openings. Examples of horizontal and vertical ribbed elements are illustrated in Figure 4-1. The size and configuration as well as the selection of horizontal elements or vertical window elements, are impacted by handling, transportation and erection requirements, and the anchor design. The structural dimensions and thickness of an element can also be affected by:

- The minimum dimension to support the installation of proper joint seals.
- The minimum dimension for adequate cover of steel reinforcement.
- The space requirements for panel handling devices.
- The space required to accommodate connection elements.

The vertical load resistance of load bearing panels can be determined using the design methods covered in Section 2.7 of the *CPCI Design Manual*.

Composite Panel Considerations

Composite double wythe insulated precast concrete wall panels will have a natural tendency to bow outwards under prolonged exposure to the sun, as the exterior wythe experiences greater temperature rise than the inner wythe. The bowing tendency is mainly influenced by panel size, the rigidity of wythe connections, and daily temperature fluctuations on the exterior face. The effect of thermal bowing can be accommodated through proper

design and detailing, such as additional panel anchor connections. For non-composite double wythe insulated wall panels, the use of outer wythe control joints can divide the element into smaller units but this is not usually necessary.

The design of panels at corners in composite double wythe insulated wall panels deserves special consideration due to this bowing tendency. The thermal bowing in the warm summer season is opposite to that occurring during the cold winter season and this can induce strain on the sealants in corner joints. During the warm summer months the panels will bow outward in the middle and thereby separate at the mid height of the corner joint. During the cold winter months, the panels will bow inward at mid height of the corner joint and thereby push the joint together at mid height but separate the joint at the top and the bottom. With non-composite double wythe insulated wall panels, this tendency is significantly reduced as the interior wythe is kept at a relatively consistent temperature and the outer wythe is allowed to expand and contract unrestrained by the interior structural wythe and is only subject to the thermal gradient within the outer wythe. Refer to Chapter 5 of the *CPCI Design Manual* for further guidance on composite design considerations.

Heat Transfer Control

The control of the flow of heat energy is a critical element of any building enclosure design. Heat energy flow across the assemblies of a building envelope not only influences the overall cost of maintaining the required comfort within the building, but also influences the relative thermal expansion and contraction of the interconnecting assembly elements. Depending upon the performance characteristics of the related elements in the wall design, the heat flow through the assembly will also influence condensation control.

In all Canadian climate conditions, buildings are designed to accommodate the flow of heat energy from inside to outside for a substantial proportion, if not the majority, of the year.

Heat energy can move by:

1. Conduction – the movement of heat energy through a material.
2. Convection – the movement of heat energy by means of a fluid such as air or water, and
3. Radiation – The movement of heat energy by electromagnetic radiation, such as infrared light.

For opaque building envelope elements, the movement of heat is driven by conduction through the materials that make up the assembly. Convective heat transfer can also influence envelope assembly performance when larger air spaces exist within the assembly, allowing warmer air to move and therefore transfer heat.

Insulation materials work by restricting the transfer of conductive energy by placing non-moving gas between two other materials. This gas, air or other, is prevented from moving by the insulation materials themselves, thus restricting convective heat transfer. Common generic insulations that provide suitable resistance to heat transfer include: mineral wool or glass fibre, cellulose, extruded or expanded polystyrene, polyisocyanurate foam, spray polyurethane foam and phenolic foam.



Precast panel wall assembly on Shear Wall.
Source: Morrison Hershfield

4.2.7 Insulating Precast Concrete Wall Assemblies

Insulating precast concrete wall assemblies is typically achieved in two ways:

1. Through encapsulation of rigid or semi-rigid insulation between an inner and an outer wythe in double wythe insulated wall panels, or
2. Through the application of semi rigid or spray foam insulation to the inside face of conventional single wythe architectural precast concrete wall panels.

A third approach is used when the precast panels are considered “thin” cladding elements, typically supported on a back-up framing system. The precast panel is attached overtop of the rest of the wall assembly, similar to other thin panel systems such as metal or ceramic panels, and the insulation is placed on the outside face of the inside wall components, independent of the precast panels. See earlier discussion in Section 2.2.1 and Section 2.2.2 on the risks to the continuity of the vapour and air barrier of using this type of construction. This construction method may be necessary for cladding air shafts and shear cores and re-cladding of existing buildings, but should be avoided, where possible, in new construction.

Selection of the amount and type of insulation is primarily dependent upon provincial energy code requirements based upon the climate zone and intended use of the interior space. These requirements may be improved upon by project specific (more demanding) energy performance requirements, and any other performance parameters placed upon the insulation layer such as providing the air barrier desired by the owner.

Energy consumption is affected by the building form, size, orientation with respect to prevailing winds and the sun, window glazing to wall area ratio, air tightness, required fresh-air exchange rates, and the thermal resistance of the various building envelope assemblies. Designers need to remember, that for many wall systems, as the insulation thickness is increased, the marginal rate of heat loss is reduced (diminishing returns). As a result, for each building system, there is an optimum insulation thickness and corresponding thermal resistance beyond which the savings in energy are not commensurate with the added cost of the additional insulation. This varies with energy costs and efficiencies in HVAC equipment.

For many buildings with internally generated heat loads such as data centres, some manufacturing operations, and heating plants, there is a point whereby the energy required for cooling the internal heat load also increases beyond the optimum, such that the annual energy consumption for cooling increases beyond that required for heating.

The overall thermal performance of the system should be based upon the effective wall RSI-value which includes losses associated with thermal bridges or changes in envelope thickness at edges.

When bonding rigid or semi-rigid board insulation to the interior face of a single wythe wall panel, it is important



Double wythe precast concrete insulated wall panel. Source: CPCI



Spray polyurethane foam applied to the back face of a single wythe precast concrete wall panel. Source: Morrison Hershfield

to provide a compatible bonding adhesive in a full bed of adhesive or a closed bonding pattern. This prevents the air from bypassing the insulation layer. Continuous contact between the insulation and the precast panel back face is preferred to prevent thermal air short-circuiting the system and resulting in condensation problems. The adhesive used must also be capable of performing in the anticipated environmental conditions (hot and cold and allow for thermal movement of the panel relative to the insulation).

Proper detailing for moisture management is critical to avoid degradation of the insulation from moisture absorption and retention, in both single wythe and double wythe applications.

4.2.8 Thermal Bridging

Thermal bridges occur when conductive materials partially or fully penetrate the primary insulation layers of the building envelope assembly. Since heat energy flows in three dimensions from warmer areas to cooler areas, thermal bridges will channel heat energy through the wall assembly, bypassing the thermal insulation, and this heat loss may result in additional energy consumption to maintain a comfortable inside temperature. If the amount of thermal bridging is significant, the overall resistance to heat flow of the wall assembly will be significantly compromised. The risk of condensation resulting from the change in surface temperature at thermal bridge locations must also be considered. If the resulting surface temperature at thermal bridge locations is at or below the dew point of the air touching the surface, condensation may form. Thermal bridges should be avoided, where possible, and properly identified and detailed to minimize condensation when unavoidable.

The relatively recent adoption of more stringent energy codes and standards, and the development of more accurate energy analysis methodologies, has raised the awareness of the impact of thermal bridging on overall building energy consumption. Many provincial and national codes and standards now mandate specific attention be placed on the reduction of thermal bridging. For more detailed information and data on the impact of thermal bridging on overall energy performance, see *Meeting and Exceeding Building Code Thermal Performance Requirements*, by RDH Building Science Inc.

Architectural precast concrete wall assemblies are well suited to minimize thermal bridging at interfaces and connections. Since precast panels typically have relatively few anchor locations over a large panel area, the primary insulating layer can cover a significant portion of the overall assembly surface without interruption. Minimizing the thermal bridging effects of the anchors for double-wythe precast panels is not necessary since the primary insulation layer is located to the exterior of the anchors. For single-wythe precast panels, minimizing the thermal bridge at anchors involves the provision of continuous thermal insulation around the anchor that effectively separates it from the interior. This is often successfully achieved using polyurethane spray foam to encapsulate the anchor once the panel has been installed and fully aligned.

Balcony Slabs

Conventional cast-in-place concrete balcony slab construction creates significant thermal bridging that has traditionally been ignored due to the perceived difficulties in separating the projecting concrete slab elements from the inner floor slab construction. As building energy codes have become more stringent and increased energy efficiency is pursued, alternate construction methods and technologies, such as the use of precast concrete balcony slabs, are being implemented. In addition to strategies that minimize thermal bridging, sloping for slab drainage, and waterproofing of the slab-to-wall transition can be integrated in the precast balcony slab design to ensure that all of the required building envelope performance criteria are continued at this interface.

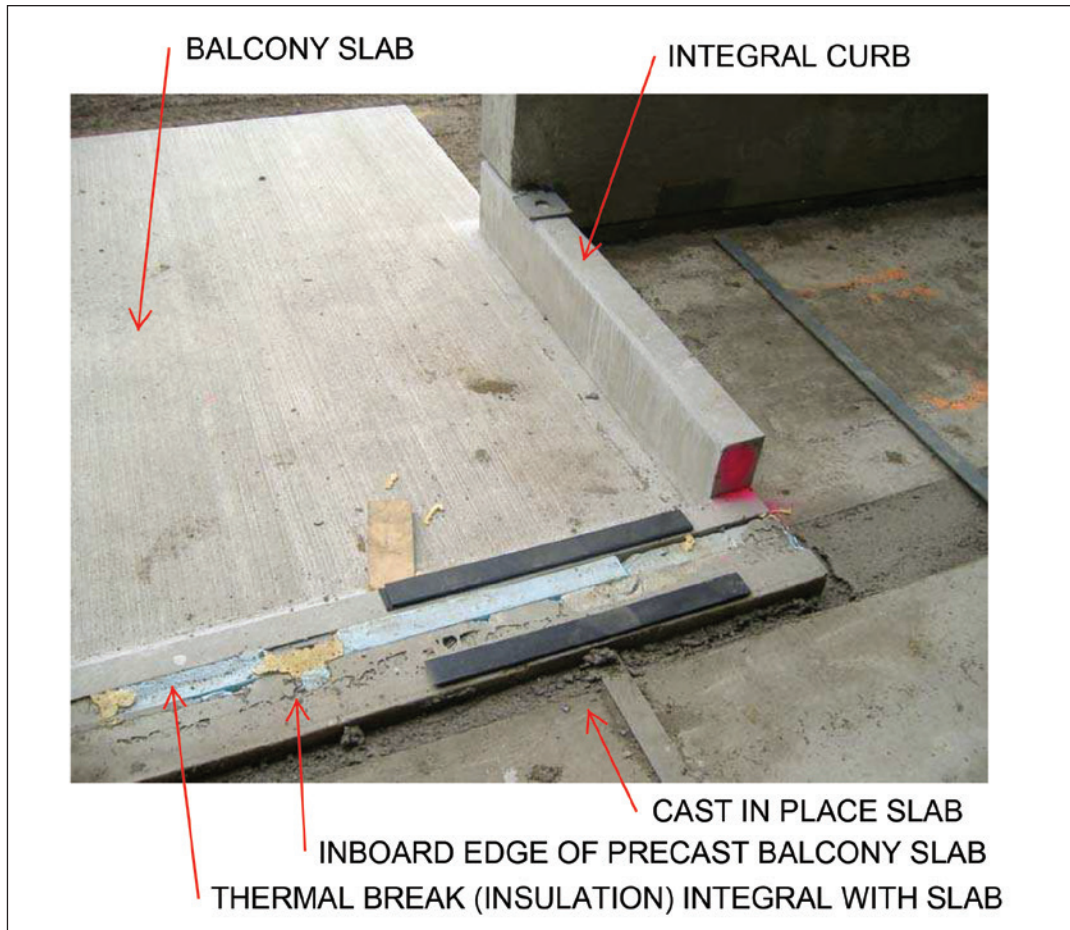

Precast balcony slab, with integrated perimeter curbs and thermal insulation break between balcony and interior slab. Source: CPCI



Precast panel connection prior to encapsulation to prevent thermal bridging. Source: Morrison Hershfield



Precast panel anchor after spray foam encapsulation to prevent thermal bridging. Source: Morrison Hershfield

4.2.9 Thermal Mass Effects

“Thermal mass” is a term related to how well a building and its materials are able to store and release heat energy. High thermal mass materials will absorb energy when surface temperatures are high, and release it when the surrounding temperatures are low. In this manner, excess heat energy can be absorbed within the material to cool the surrounding environment until it reaches the ambient temperature and release it when needed at a later time. High thermal mass materials help to reduce fluctuations in temperature in a space and reduce the energy load on those spaces.

In modern high performance energy design, thermal mass effects are sometimes used to improve occupant comfort by absorbing passive heat from solar radiation during the day, then releasing the excess heat overnight when the sun has set and heat is required. The absorption of heat by the high thermal mass material during a hot day acts to cool the environment during the heat of the day, thereby reducing cooling loads. Higher density materials like concrete are considered high thermal mass materials and can absorb significant amounts of heat energy. These thermal mass effects can be integrated into an overall energy management methodology.

Designers are encouraged to take thermal mass effects into consideration when designing a building such that any potential negative effects are properly managed, and any potential positive effects are maximized to the benefit of the design. More discussion on design for thermal mass can be found in Section 4.10.2, and also by following this link http://www.sustainableprecast.ca/en/precast_sustainability/thermal_mass/

4.3 Air Leakage Control

Control of air movement through a building envelope assembly is critical as it affects many building performance issues:

- Heating / cooling loads
- Condensation management
- Thermal comfort
- Rain penetration control
- Smoke movement
- Sound transmission

Typically, control of air leakage is achieved with an air barrier assembly, which is a designated combination of materials and / or components that provide a continuous barrier to the movement of air across the assembly. Refer to the Guide *High Performing Precast Concrete Building Enclosures - Rain Control* by RDH Building Science Inc., at the following link for more information: http://www.cpci.ca/en/resources/technical_publications/

Properties of a successful air barrier design and installation include:

1. They are constructed of airtight materials as follows:
 - Material $0.02 \text{ l}/(\text{s}\cdot\text{m}^2)@ 75 \text{ Pa}$ (0.004 cfm / sf @ 0.3" WC)
 - Assembly $0.20 \text{ l}/(\text{s}\cdot\text{m}^2)@ 75 \text{ Pa}$ (0.04 cfm / sf @ 0.3" WC)
 - Enclosure $2.00 \text{ l}/(\text{s}\cdot\text{m}^2)@ 75 \text{ Pa}$ (0.4 cfm / sf @ 0.3" WC)
2. They are continuous within the building envelope (across joints within the assembly and across junctions with other components and assemblies),
3. They are structurally sufficient to resist wind loads and transfer all loads to the primary building structure, and
4. They are sufficiently durable to provide appropriate performance for the service life of the building.

For an air barrier to be effective, it must be continuous across all building elements and building envelope assemblies. This is a critical principle that must be fully addressed in the design and construction of the assembly. Unfortunately, insufficient attention is typically given to this principle, which often leads to premature assembly failure.

Leakage of interior air outward through the building envelope (exfiltration) can result in accumulation of significant quantities of condensation (and / or frost) and is a primary cause of moisture-related building problems. These problems can be avoided if sufficient air-tightness is achieved in the building envelope through implementation of proper detailing and construction.

In single wythe architectural precast concrete wall panel assemblies, the plane of air tight continuity is located within the precast concrete, and continues from panel-to-panel through the inner seal of the two-stage sealant joints. If spray applied polyurethane foam is applied to the back of the single-wythe panels, it too can be considered an air tight element and can be used to transfer the plane of air tightness to adjacent assemblies when properly detailed and constructed. Spray applied polyurethane foam insulation does however become rigid with time and may crack if the precast panel moves due to thermal expansion and contraction.

In double-wythe insulated precast concrete wall assemblies, the inner structural wythe of the panel is designed as the air barrier plane, with continuity of the air seal through the inner seal of the two-stage sealant joints. This inner wythe experiences very little thermal expansion and contraction as it remains at a fairly constant temperature, thereby reducing stresses on the inner seal of the two-stage joint adding to its longevity.

Careful selection of materials is needed when transferring the air barrier seal from the precast panels to adjacent assemblies such as other cladding materials, fenestration systems, and roofing. Materials must be compatible with the materials that they contact, and the attachment must be both strong enough to withstand the expected air pressure loads and durable enough to perform for the expected life cycle of the wall system.

4.4 Vapour Diffusion Control

Vapour diffusion control is a requirement of the building code to mitigate the potential accumulation of condensation within building envelope assemblies. Control of vapour diffusion is provided by utilizing materials with lower vapour permeance to prevent the movement of the water vapour from spaces with higher vapour pressure to spaces with lower vapour pressure.

Vapour pressure is a function of the temperature of the air and the moisture contained within the air. The relative humidity (RH) of air at a given temperature is the percentage of moisture in the air compared to the maximum amount of moisture that the air can hold at that temperature. As the air temperature drops, the amount of moisture that air can hold as a vapour also drops. When the air reaches a temperature where the moisture content is the maximum it can hold at that temperature (100%RH), the air has reached its dew point temperature. If the air then comes in contact with a cool surface, below the dew point temperature, moisture will condense on the surface as liquid water.

Table 2: Examples of relationship between air temperature, relative humidity, and dew point temperature.

Air Temperature	Relative Humidity	Dew Point Temperature (approx.)
20°C	30%	+ 2°C
20°C	50%	+ 9°C
25°C	30%	+ 6°C
25°C	50%	+ 14°C
35°C	40%	+ 20°C

It is important to understand what the intended interior air temperature and moisture content conditions will be when designing the appropriate vapour control strategy in an assembly. The underlying intent is to prevent air from reaching its dew point, unless the condensation of moisture will not affect performance of the materials, components, or assemblies. Different materials have different vapour control properties, referred to as vapour permeance or vapour permeability. The amount of vapour control required is directly related to the anticipated environmental conditions on the two sides of the wall assembly, including temperature and air moisture content ranges. The vapour control strategy must allow for drying of the wall assembly when conditions allow. It is very important that the wall be designed to provide the correct amount of vapour control for the climate and environmental conditions on each side of the wall.

Construction materials have different vapour permeance characteristics, and vapour permeance changes for some materials depending upon the temperature and moisture content conditions of the surrounding air. Well designed, mixed, and cured concrete has a relatively low vapour permeance, which varies with concrete thickness. Foil or asphalt impregnated paper wrapping fiber insulation, polyethylene films, asphalt membranes, vinyl wallpaper, and certain types of paint all have low vapour permeance properties.

For most buildings built in Canada, an appropriate vapour control strategy is needed to prevent interior warm, moist air from reaching colder components of the assembly during the winter months. Precast concrete architectural panels will perform as an appropriate vapour control strategy. The other advantage of precast concrete panels is that they are unaffected by moisture and are not a food source for mould, thereby being able to withstand some degree of moisture accumulation, remain intact and not become a health concern.

Vapour Diffusion Control Strategies:

- A. **Single wythe precast concrete wall panels (with insulation on the interior surface of the panels)** – Low vapour permeance materials may be required on the interior of the insulation layer, or if the insulation layer is an extruded polystyrene or spray applied polyurethane foam, then the insulation itself can act as the appropriate vapour control layer, if properly designed and installed to achieve this criteria. For example, 50mm of polyurethane spray foam has a vapour permeability of less than 60ng/Pa·s·m², which is sufficient for most applications.
- B. **For double wythe insulated wall panels** – a 100 mm concrete inner structural wythe may have sufficiently low water vapour permeance (approximately 45 ng/Pa·s·m²) to serve as the vapour management layer. It is important that the interior surface of the inner wythe be maintained above the dew point temperature of the interior air that touches it. This can be quantitatively assessed using proper thermal modeling. Any modeling should include any accessory elements that influence the flow of heat to the wythe.

4.5. Precipitation Control

4.5.1 Causes of Water Leakage Across the Building Envelope

Water migration into a wall assembly requires the following conditions to occur concurrently (K. Garden, CBD-40, 1963):

1. A source of water, such as rain or melting snow and ice,
2. A crack or opening, and
3. A force to move the moisture through the opening, such as
 - air pressure
 - kinetic energy
 - gravity
 - capillary forces

In the reality of the built-environment, it is considered a reasonable design practice to assume that there will always be a source of water and cracks or openings in a building envelope. Although all attempts should be made to prevent both of these from occurring, as part of a design strategy, in practice they should be expected in any building envelope. Controlling water leakage into a building envelope assembly needs, therefore, to be addressed by understanding and managing the forces that move water through an opening.

4.5.2 Water Leakage Forces

4.5.2.1 Air Pressure Differences

Water infiltration into the building envelope can be driven by air pressure differences across the envelope, specifically air infiltration. When an air pressure difference occurs at an opening, air moves through the opening and can carry water with it.

A building should be constructed with a continuous air barrier layer as part of the building envelope assembly. The intent of the air barrier assembly is to prevent the movement of the air across that layer, which eliminates the movement of water and the embodied heat energy and moisture contained within the air itself.

Even with a successful air barrier layer within a building envelope assembly, air pressure differentials across openings between envelope elements in locations outside of the air barrier layer can still move water across the element. For example, openings between exterior cladding components can allow water to pass if wind gusts create a pressure difference across the opening.

There are three primary factors which create air pressure differences across the building envelope:

1. Stack effect,
2. Wind, and
3. Mechanical ventilation systems.

Stack effect is the buoyant effect of warm air over cold air, and typically occurs in Canadian weather conditions during the autumn, winter and spring when outdoor air is cooler than indoor air. The interior warm air rises above the cooler outdoor air (like a hot-air balloon), resulting in indoor-to-outdoor air pressure differentials ("positive" air pressure) in upper floor areas, and corresponding outdoor-to-indoor air pressures ("negative" air pressure) on lower levels. Any holes in the air barrier assembly of the building envelope will result in air exfiltration on upper levels, and infiltration on lower levels. Stack effect air pressure differentials are directly related to the height of the building and the difference in temperature of the indoor and outdoor air. These air pressure differentials do not

tend to be large in value but do occur on a continuous basis. A reduction in the height of the air column reduces this effect but does not eliminate it.

Wind against a building creates air pressure differentials that vary in magnitude, location, and type depending upon the speed, duration, and direction of the wind. They are also dependent upon the plan dimensions and shape of the building as well as influences from the local surrounding landscape. Positive and negative wind pressures vary around the building as well as across a building facade and it is difficult to determine the precise effect of wind on a building surface. Wind studies of a proposed building shape set in its local context and environment can assist with determination of the limits of wind pressures such that proper building envelope design can be provided.

Mechanical ventilation systems can also create internal positive and negative air pressure differentials depending upon the design of the system and its controls. Often, mechanical systems attempt to reduce the impact of stack effect pressures to improve the operational use of the building, such as opening of doors, and the control of air quality. Poorly designed or controlled HVAC systems can create unwanted air pressure differentials across the building envelope that can result in water penetration through openings.

4.5.2.2 Capillary Action

Moisture movement related to capillary action results from water surface tension in narrow inter-connected spaces that enables a liquid to move through porous materials such as masonry, and to a lesser degree, concrete. In capillary active materials, moisture is absorbed, stored, and transported through the material and provides another means for moisture migration through a building envelope assembly. Capillary action can move water in any direction as surface tension forces may be higher than gravity forces within small spaces. In non-absorptive (non-capillary active) materials, for example glass or metal (without cracks), water runs off and there is no capillary-related absorption.

Surface tension forces can move water across air gaps between materials if the gaps are sufficiently small, and the surfaces of the materials on either side of the gap have adequate roughness to allow the water to adhere. This is one of the reasons why the drainage gap in rain screen wall design is recommended to be at least 10mm wide, to allow the gravity forces on a drop of water to overcome the surface tension across the gap.

4.5.2.3 Kinetic Action

Kinetic action is the result of kinetic energy that is embodied in a mass under movement. When referred to in building envelope design, kinetic action normally refers to the kinetic energy in a water droplet that is blown against an assembly by the wind. Even when the wind is removed from the moving drop of water, it will continue to move in the same direction as when the wind was carrying the drop due to momentum, and can force the water through cracks and openings in the building envelope.

4.5.2.4 Gravity

Water flows from higher to lower elevations due to the force of gravity. When a hole exists in the exterior of the building envelope (either purposefully or not), rain water will shed over the building envelope component and not enter if the hole is shaped to allow gravity to move the water down. It is preferable to lead water away from holes in the building envelope, regardless of design, to ensure water will not enter and create problems.

4.5.3 Water Leakage Control Strategies

The designer should work with the precast concrete manufacturer to develop proper water control details within the precast system.

Various water leakage control strategies exist for vertical building envelope assemblies:

1. Mass (storage and release),
2. Drained (screened and drained enclosure), and
3. Perfect Barrier (face sealed or concealed barrier).

4.5.3.1 Mass Assemblies

The mass or storage approach assumes rainwater that strikes the exterior surface of the building envelope component will either drain off the surface of the component or be absorbed into the component. It is also assumed that the component has sufficient water storage capacity and moisture tolerance to absorb the water until it may be released without detrimental effect.

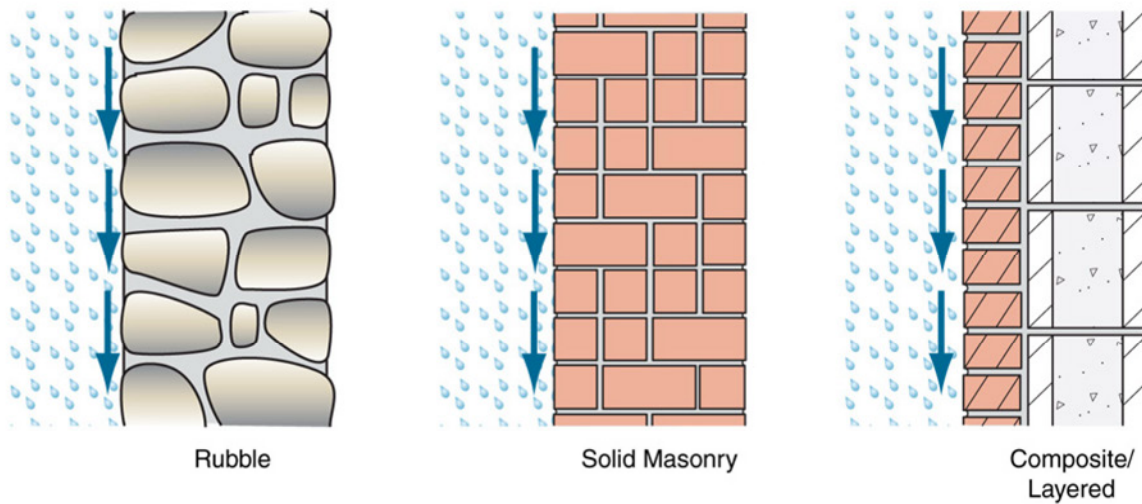

Figure 4-2: Examples of mass or storage approach to precipitation management. Image copyright RDH Building Science Inc., used with permission

Release of the absorbed water is very important for this approach to wall design and relies upon evaporative drying when the wetting period has ended. The rate of drying is dependent upon capillary/surface tension forces and differences in water vapour pressure. Drying can occur either to the exterior, to the interior, or both. Careful attention to the overall wall design is required, including placement and amount of insulation, vapour permeance of surrounding materials, and the anticipated amount of heat flow through the wall system.

Examples of mass wall assemblies include;

- multi-wythe stone, masonry, and/or rubble walls
- porous concrete or cinder or concrete block walls

4.5.3.2 Drained Assemblies

A drained assembly describes a system where exterior water is anticipated to pass through the exterior surface and is then intercepted and re-directed back to the exterior before it can affect water-sensitive materials.

Typically, an air space is provided behind exterior cladding elements. The air space serves as both a capillary break and a drainage plane to evacuate water from the wall assembly. The cladding serves as a screen, hence the term “rain screen”. Water that does penetrate the cladding or “screen”, runs down a water-tight drainage plane and is



Handset precast panels installed in a drained wall system. This approach might be necessary for retrofit projects but is discouraged for new projects (See section 2.2.1). Image copyright RDH Building Science Inc., used with permission

lead out of the wall system by way of through-wall flashings and weep holes. Walls where the cladding incorporates holes at the base of wall are typically described as “vented”, whereas those that include two openings (typically at the top and bottom of the wall) are called “ventilated”. Pressure equalized or pressure-moderated walls are a specific type of rain screen where the air pressure behind the cladding is managed by the wall design so that it closely resembles the air pressure outside, so that the driving force of the moisture due to air pressure difference across the layer is minimized.

Modern brick veneer, lap siding and metal panel systems are good examples of successful drained cladding systems.

Although precast concrete panels can be installed in a drained assembly, where the precast panels are installed after the construction of a back-up wall, this practice is discouraged for new construction due to the penetrations that must be made through the thermal, air and vapour layers for connections (See Section 2.2.1) – and since it is also typically very difficult to provide a continuous drained cavity behind a precast assembly. When it is done for retrofit projects it should also include proper two-stage drained joints for the drainage (See Section 5.3.1).

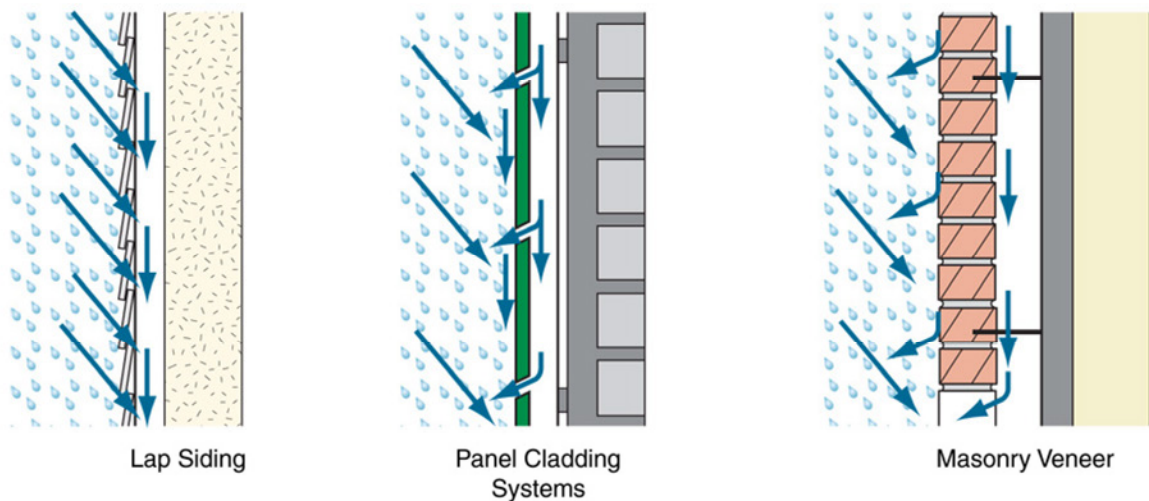

Figure 4-3: Examples of drained approach to precipitation management. Image copyright RDH Building Science Inc., used with permission

4.5.3.3 Perfect Barrier

The perfect barrier precipitation control strategy is one where water leakage control occurs at one plane within the envelope assembly, typically either the most exterior surface (“face sealed”) or at an inner surface (“concealed barrier”) of the envelope.

Examples of face-sealed wall assemblies include insulated metal panels and traditional stucco, where the exterior face of the wall and its caulked exterior joints provide the only line of defense against water ingress. Face-sealed systems have a long history of water leakage problems, as the joints between the cladding elements are difficult to construct and maintain for perfect water tightness, especially when the face of such systems are very thin. In Canadian climates, the face-sealed strategy has typically been shown to be unsuccessful and is not recommended.

Concealed barrier systems in walls include claddings such as stucco and adhered claddings installed directly over a water tight sheathing membrane, such as non-drained EIFS. Moisture-induced damage for these types of wall

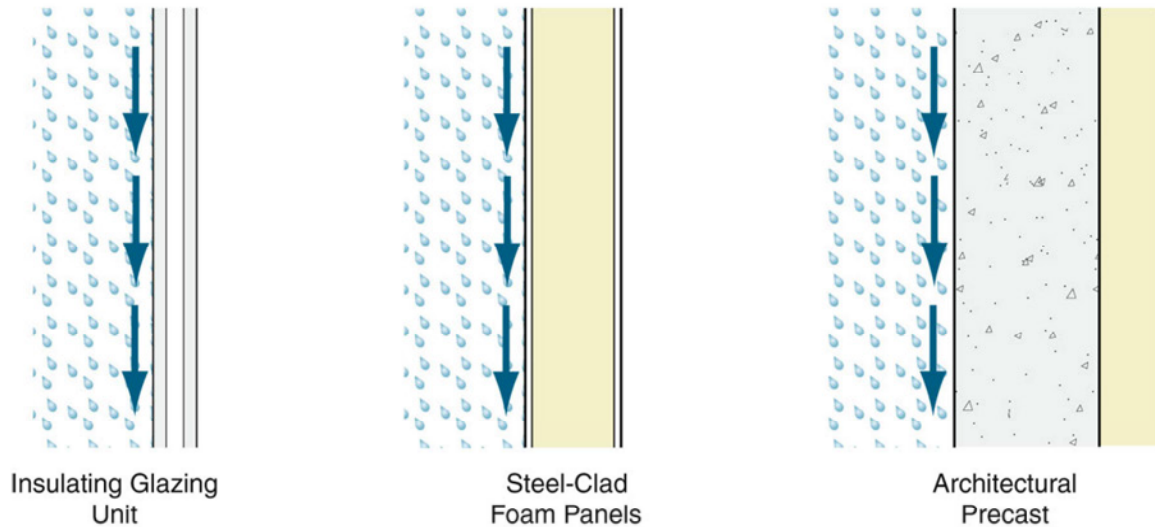

Figure 4-4: Examples of the perfect barrier approach to precipitation management. Note that the architectural precast panel joints should be designed as two-stage joints (See Section 5.3.1). Image copyright RDH Building Science Inc., used with permission

systems is attributed to water ingress and accumulation at joints and cracks and an inability of the sheathing membrane to provide long-term water tightness or water durability under these conditions.

Single wythe architectural precast concrete wall panels with a single-stage joint are considered by many to be a form of perfect barrier, face sealed cladding system, but are not recommended.

However, single wythe precast concrete panels and double wythe precast concrete insulated wall panels with a two-stage joint system are a combination of a perfect barrier and a concealed barrier system. The two-stage joint system provides the exterior seal that acts as the barrier to rain for the interior seal which is concealed and protected from the damaging elements of the environment. As long as the quality control of the precast concrete is high and the two-stage joint system between precast panels are properly designed, installed and maintained, the assembly has proven to provide good long-term durability in actual use in all Canadian climates. This is called a **'perfect barrier drained joint system'**, and is the recommended approach for precast concrete wall assemblies.

4.5.3.4 Precipitation Design Considerations

Typical design considerations include:

- Rain water and snowmelt moving over the precast cladding surface deposits dirt in concentrated locations and washes other areas clean. The patterns created by deposition and washing can be anticipated and controlled.
- Minimize horizontal or low sloped elements that collect dirt. Minimum slope should be 1:3.
- Provide protection for vertical surfaces with steep sloped overhangs and drips at storey levels to reduce dirt washing onto the vertical surfaces below and to provide improved water shedding.
- Vertical ribs, reveals or grooves control water runoff and prevent horizontal or diagonal dirt distribution.
- Medium textured finishes, while accumulating more dirt, do so more uniformly.
- Dark colours, including grey, will mask dirt accumulation.

- Water runoff will tend to follow vertical channels, pilasters, window frames and panel joints. Maintain these water paths from top to bottom to carry runoff and dirt to the ground. Terminate horizontal elements a clear distance away from vertical projections.
- Provide drips in precast above windows, or provide drip flashings as part of the window junction to avoid runoff etching the glass surfaces.
- All overhanging precast elements should be provided with drips to break the surface tension of water flowing along a horizontal or inclined surface.
- Drip profiles should include sharp edges.
- Chips on the edges of precast sections create unintentional drips. Provide a radius on panel corners to reduce chipping.



*Drip Edge on a Precast Concrete Panel.
Source: M. E. Hachborn Engineering*

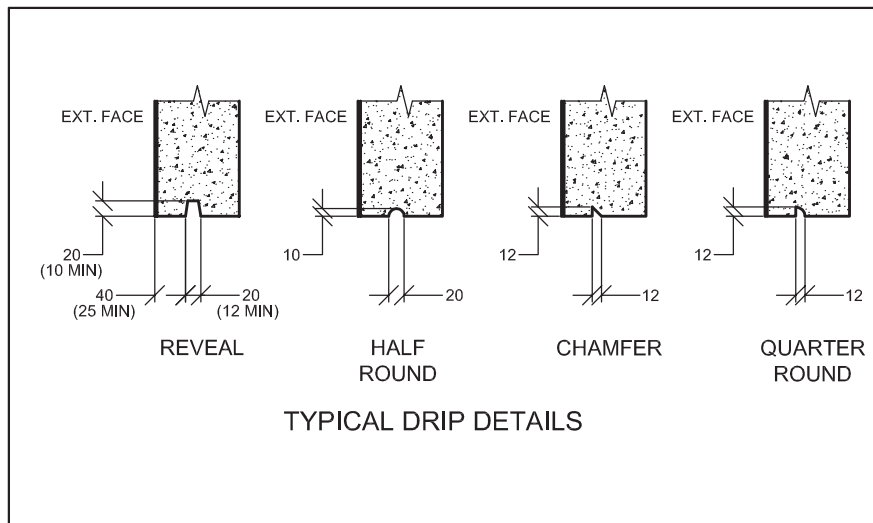

*Figure 4-5: Typical Drip Edges on a Precast Concrete Panel.
Source: M. E. Hachborn Engineering*

4.6 Noise

Local codes and by-laws have specific requirements relating to noise transmission. The following table provides design considerations related to precast wall design:

- Noise separation becomes an important design issue when the building is located near a significant noise source such as an airport or busy highway. Typically precast concrete elements have sufficient mass to provide effective damping and sound insulation.

- The sound transmission of a wall is largely determined by the performance of the windows and doors, and by the air tightness of the assembly. Windows and doors should also be part of the design strategy for improved sound insulation.
- A continuous air barrier system will also have a positive impact on the sound insulation of the assembly.
- A 100-mm thick concrete wall panel has an STC (sound transmission class) of 50, which is the minimum STC required between dwelling units by the National Building Code of Canada (NBCC, 2015).
- Adding insulation and gypsum board raises the STC further, such that a precast concrete assembly can easily be designed to exceed the minimum value.
- With the introduction of the new ASTC (apparent sound transmission class), assemblies are now rated for sound transmission through all flanking paths in an assembly (NBCC 2015)

4.7 Solar and Ultraviolet Radiation

Durability is an over-riding consideration for building envelope performance, and must consider not only the material properties, but the service conditions to which the material or component will be subjected. Unlike other cladding materials that may be vulnerable to ultraviolet deterioration in the long-term, precast concrete is inherently resistant to UV degradation.

As with other cladding systems that have sealant in the joints, the sealants are susceptible to ultraviolet damage to varying degrees, depending on the exposure, the sealant type and the product used. However, for a precast concrete wall system with a two stage joint system, ultraviolet radiation will only effect the outer sealant, and the inner sealant will not be effected. Nevertheless, the outer seal requires maintenance and periodic replacement. Joint design and sealant selection is discussed in more detail in Chapter 5 and maintenance is discussed in Chapter 7. Reference can also be made to the *CPCI Maintenance and Inspection Manual for Precast Concrete Building Enclosures* (2016)

4.8 Fire

The fire performance of precast panels is usually not a concern since concrete is noncombustible. When a fire resistance rating is required for an exterior wall, these factors affecting the rating, from the *Concrete Design Handbook* (Cement Association of Canada, Fourth Edition), need to be considered

- Concrete type, dependent upon the aggregates used
- Member dimensions
- Type of reinforcement
- Cover to the reinforcement
- Panel restraint and continuity
- Protected construction

The fire-resistance ratings of concrete construction can be determined in accordance with guidelines provided in the governing building code. Guidance is also included in Chapter 6 of the *CPCI Design Manual* and in the *CAC Concrete Design Manual*.

Fire tests conducted by Gustafarro and Abrams (1975) on wall panel joints demonstrated that the fire endurance, as given by the increase in temperature of 181°C over the joint, is affected by the joint type, joint materials, and the panel thickness. When insulating material of proper thickness is provided, fire endurance equivalent to that of the panel can be achieved. For example, a single stage joint width of 10 mm filled with 6 mm of ceramic fibre

felt provides a 1 hour fire resistant rating, which is equivalent to that provided by 90 mm concrete panel. Refer to Chapter 6 of the *CPCI Design Manual* for more information.

The building code permits the use of minor combustible components such as caulking material at a seal between the major components of exterior walls in non-combustible construction (refer to NBC Division B, Sentence 3.1.5.2(1)).

Combustible components such as plastic insulation used in non-combustible construction must meet the requirements of NBCC Div B, Article 3.1.5.6. The combustible insulation must also be covered by one of various thermal barriers, depending on the flame-spread rating of the material, as per Article 3.1.5.14 of the NBCC (NRCC, 2015). This applies not only to the panels, but also to the joints between panels. Note that, in double wythe precast concrete insulated wall panel assemblies, the insulation is encapsulated by the concrete wythes, except at the edges of the panels at the joints.

Precast exterior wall panels incorporating plastic insulation generally meet the requirements for protection of the exterior building face that are stated in Sentence 3.2.3.8(1) of the National Building Code (NRCC, 2015). Information on the fire endurance (heat transmission) of concrete walls and slabs as a function of aggregate and concrete thickness is given in Chapter 6 of the *CPCI Design Manual*.

By regulation, fire-stopping must be installed to prevent fire and smoke transmission between floors. Since precast panels are typically hung on the outside of the building frame, fire and smoke seals must be provided at the slab level between the inside edge of the precast panel and the edge of the floor slab. Designers should confirm the fire protection requirements of applicable codes and regulations with the authority having jurisdiction.

4.9 Durability

Durability is defined in the CSA Guideline S478, *Guideline on Durability in Buildings*, (CSA, 1995 (R2007)) as;

“...the ability of a building or any part of its components to perform its required functions in its service environment over a period of time without unforeseen cost for maintenance or repair.”

The same guideline also states that the predicted service life of buildings and their components should meet or exceed their design service life. The design service life of various building types is given in Table 2 of the Standard, varying from 10 years for temporary buildings, and up to 100 years or more for buildings identified as “permanent”, with “long life” buildings having a design service life ranging from 50 to 99 years. This latter category typically applies to residential, commercial, office, health and educational buildings. When properly designed, constructed and maintained, precast concrete wall systems have been proven to be one of the most durable building envelope components available, with a proven history of use in Canada of more than 60 years.

There are two avenues in LEED™ version 4 to recognize qualities of durability. Under the LEED v4 Building Design + Construction (BD+C) rating system (which includes New Construction), the first is in the Energy and Atmosphere credit, Enhanced Commissioning (<https://www.usgbc.org/credits/new-construction-core-and-shell-schools-new-construction-retail-new-construction-healthca-17>), a new option for envelope commissioning which specifically says:

“Fulfill the requirements in EA Prerequisite Fundamental Commissioning and Verification as they apply to the building’s thermal envelope in addition to mechanical and electrical systems and assemblies. Complete the following commissioning process (CxP) activities for the building’s thermal envelope in accordance with ASHRAE Guideline 0–2005 and the National Institute of Building Sciences (NIBS) Guideline 3–2012, Exterior Enclosure Technical Requirements for the Commissioning Process, as they relate to energy, water, indoor environmental quality, and durability.”

The other is under **Innovation** (<http://www.usgbc.org/node/2613903?return=/credits/new-construction/v4/innovation>), strategies not addressed in the LEED credits already, can be awarded for innovation:

“Achieve significant, measurable environmental performance using a strategy not addressed in the LEED green building rating system.

Identify the following:

- the intent of the proposed innovation credit;*
- proposed requirements for compliance;*
- proposed submittals to demonstrate compliance; and*
- the design approach or strategies used to meet the requirements.”*

At the design stage, the exposure conditions, including any chemical constituents and impurities that may react with the concrete must be considered. Severe weather may cause some deterioration of the concrete due to freezing and thawing conditions or chloride exposure. For this reason, 5 to 8 % air entrainment is recommended for all exposed panels in all Canadian climate zones. CSA A23.1/2 (2014). See Section 5.3.1.4. Concrete Materials and Methods of Construction provides guidance for the design of concrete mixtures for various exposure classes. Corrosion protection of precast concrete panel anchors should also be considered, particularly when the anchors are located outside the wall assembly's moisture barrier (for example, single wythe wall panels installed in a drained wall system).

While predicted service life of precast concrete elements can generally meet or exceed the building design service life, sealant joints have a shorter service life (which varies depending on the sealant selected). However, sealant joints are relatively easy to access and maintain, and as such meet the intent of the LEED Canada Durable Building credit. Similarly, surface sealers applied to precast concrete panels for special applications such as to reduce moisture uptake and the formation of algae, or as anti-graffiti coatings, have a shorter predicted service life, but can easily be maintained. Any coating such as sealers or paints applied to precast panels should be vapour permeable to prevent the accumulation of moisture behind the coating, and premature deterioration of the coating or the concrete.

Durability issues to be considered:

- Freeze-thaw resistance of the concrete
- Weathering of the finish
- Corrosion of the reinforcing steel
- Joint sealant performance
- Glass etching from water runoff
- Vapour permeance of any applied panel coatings
- Access for maintenance

4.10 Energy

Sustainability and green building programs such as LEED™ encourage energy savings beyond minimum code requirements. The energy saved is a cost savings to the building owner through lower monthly utility bills, and potentially smaller, less expensive heating, ventilating and air-conditioning (HVAC) equipment. The ultimate goal is to reduce the total greenhouse gas emissions to the atmosphere from fossil fueled power plants and heating appliances over the entire service life of the building.

The design of an energy-conserving or sustainable building requires the understanding, by the architect, of the effects of decisions on energy performance. Depending on location, upwards of 50% to 90% of the global warming potential and total primary energy impacts incurred during the service life of a building may be attributed to building operation and energy consumption (CPCI, 2012). An integrated design approach considers how each

component interacts with the building, building occupants and/or its HVAC system. The implementation of this approach early in the design phase helps optimize environmental impact and initial building cost, while reducing long-term heating and cooling energy costs.

4.10.1 Design of Building Envelope Details

Conventional building envelope design considers nominal RSI-values of building envelope systems. Changes made to improve thermal performance generally take the form of increasing insulation thickness. Thermal bridges at wall penetrations due to elements such as structural connections should not be disregarded. As the insulation thickness is increased, the thermal benefit *per additional unit of thickness* decreases. In other words, adding more insulation provides diminishing returns with respect to the overall assembly thermal performance, and if the heat flow being drawn to thermal bridges is not considered, the returns are even less. Typically, the fewer thermal bridges in a wall assembly, the better the overall *effective* thermal performance.

As building codes become more stringent with respect to energy efficiency, the thermal performance of building envelopes, and their details, will need to be considered more carefully. Tools such as three-dimensional thermal modeling will become more useful to assess the impact of alternative design strategies, to improve envelope thermal performance and to control whole building energy loss.

4.10.2 Thermal Mass Effects

Most materials undergo an increase in temperature as they absorb heat from a heat source such as solar radiation. Some materials can store a larger quantity of thermal energy with a smaller temperature rise than others occupying the same volume. This material property is referred to as specific heat capacity. Concrete products have high specific heat capacities per unit volume due to their high mass per unit volume (density). For this reason, materials with high specific heat capacity are also described as having high thermal mass.

Interior concrete elements, including the interior wythe of double wythe insulated precast concrete wall panels, left exposed, instead of being covered by insulation and gypsum wallboard, are best able to absorb internal heat gains. Internal heat gains include heat generated inside the building by lights, equipment, appliances and occupants. Exposed concrete elements can also absorb solar radiation entering through windows. The thermal mass characteristic allows the concrete to react more slowly to changes in outside temperature, reducing peak heating and cooling loads and delaying the time at which these peak loads occur by several hours. This is especially true if the vision glass has been located to take maximum advantage of solar heat gains.

This versatility and the relative importance of particular thermal mass design strategies depend to a large extent on the building location and orientation. Buildings in northern, heating-season dominated climates are designed differently than those in southern, cooling-season dominated climates. Considerations include; building shape, size and orientation, number of stories, type of building envelope, glazing area, shading, exterior colour, texture, wind direction and speed, air infiltration, ventilation, reflections from adjacent structures, and surrounding vegetation. Given the number of parameters affecting the thermal mass effect, quantifying the benefit is more challenging than calculating RSI-values.

Saving heating and cooling energy with thermal mass should be considered at the design stage. Design considerations fall into two categories, those that define the opportunity for saving and those related to the effectiveness of thermal mass in its energy saving role.

Factors Defining the Opportunity for Thermal Mass Benefits

- Solar gains through windows for example, windows that are designed to allow the sun to optimally heat interior concrete surfaces.
- Internal heat gains (for example, occupants and equipment) accounted for in the design.

- Higher than normal insulation levels (RSI values of the envelope) designed to take full advantage of heat retention and release.
- Ventilation designed for thermal mass considerations.

Primary Factors Defining the Effectiveness for Thermal Mass

- The amount, heat capacity and location of building mass in the design.
- Thermal coupling between the concrete mass and the HVAC system.
- Ensuring HVAC system control provisions are in place after construction and during occupancy of the building to ensure the building operates as designed.
- Ensuring, through design and construction, that building envelope thermal bridging is minimized or eliminated.

4.11 Aesthetics

The aesthetics of the building facade are the responsibility of the designer, usually an architect and, in the case of architectural precast wall panels, is achieved in collaboration with the precast manufacturer. Architectural precast offers unparalleled design flexibility because of its fluidity when in its plastic state, and the range of colours, textures and finishes available. The aesthetic choices are wide and varied (See Chapter 2). The CPCI *Architectural Precast Concrete Colour and Texture Selection Guide* offers excellent guidance and ideas for the design professional.

4.12 Life Cycle Assessment

In order to better understand precast concrete’s environmental performance in the context of building construction, use, and end-of-life, a life cycle assessment (LCA) of a typical commercial building with five variations of building envelope and three variations of structural framing in two Canadian locations was conducted (CPCI, 2012). The building types were modeled in two cities representing two Canadian climates: Vancouver, British Columbia—a cool climate (Climate Zone 5C)—and Toronto, Ontario—a cold climate (Climate Zone 6A). The LCA study was a cradle-to-grave LCA, conducted in accordance with ISO standards. Since the LCA included a comparative assertion intended to be disclosed to the public, an independent external committee of LCA and technical experts critically reviewed the methodology and results.

Table 3. Building envelope and structure type used in the CPCI LCA Study (2012)

Building Envelope Type (Abbreviation)	Structure Type and Abbreviation		
	Steel (S)	Cast-in-place Concrete (C)	Precast Concrete (P)
Curtain Wall (CW)	CW-S	CW-C	CW-P
Brick and Steel Stud (S)	S-S	S-C	S-P
Precast Concrete (P)	P-S	P-C	P-P
Insulated Precast Concrete (Pi)	Pi-S	Pib-C	Pi-P
Insulated Precast Concrete and Thin-Brick Veneer (Pib)*	Pib-S	Pib-C	Pib-P

* Note: The Thin-Brick Veneer utilized bricks 13-16 mm (1/2 to 5/8”) thick, cast into the face of the precast concrete panels.

The following is a highlight of the LCA study:

1. During Occupancy (60 and 73 year scenarios) the buildings with the *lowest* global warming potential (GWP), regardless of location and service life, were the buildings with precast concrete envelope and cast-in-place concrete structural frames (P-C, Pi-C, and Pib-C).
2. During Occupancy (60 and 73 year scenarios), as with GWP, the buildings with the *lowest* total primary energy (TPE), regardless of location and service life, were the buildings with precast concrete envelope and cast-in-place concrete structural frames (P-C, Pi-C, and Pib-C).
3. During Occupancy (60 and 73 year scenarios), the buildings with the *highest* TPE and GWP (60 and 73 year scenarios) were all steel structural frames, regardless of location and service life, with curtain wall envelope and steel structure (CW-S) having the highest TPE and GWP in all cases.
4. With energy simulation, it was found that the interior thermal mass inherent in cast-in-place concrete and precast concrete floors (compared to concrete toppings on metal deck) reduced annual heating energy use by 6 to 15% and reduced total annual energy use by 2 to 3%.
5. Operating energy was responsible for 54 to 75% of the GWP in Vancouver (the range represented service lives of 60 and 73 years, respectively), and in Toronto, 90 to 91% of the GWP was due to operating energy (dependant on service life).
6. Operating energy accounted for 90 to 97% (depending on location and service life) of the cradle-to-grave embodied energy (TPE).
7. For all the buildings in Toronto and Vancouver, for operating energy from cradle-to-grave, electricity use was responsible for the majority of impacts in most of the impact categories, including: global warming, acidification, respiratory effects, eutrophication, photochemical smog, solid waste, ozone depletion, and total primary energy; both fossil and non-renewable.

LCA and Portland Limestone Cement (PLC)

When Portland Limestone Cement (PLC) was modelled in the manufacture of precast concrete and the production of cast-in-place concrete, the environmental impacts were reduced. The GWP was reduced 6 to 9% and total primary energy was reduced 4 to 7%. There were also significant reductions in impacts associated with acidification, respiratory effects, eutrophication, smog, water use, non-renewable energy, and renewable energy (non-biomass).

Over the life of the building, when PLC is substituted for Ordinary Portland Cement (OPC) in concrete at the rate of 12%, the environmental impacts are reduced. The data showed that a 12% replacement of PLC for OPC reduced the GWP by approximately 60,000 kg CO₂ eq. The entire reduction occurred in the manufacturing stage. Since the absolute GWP of the building in Vancouver was less than that for the one in Toronto, the relative reduction due to PLC was less in Toronto than in Vancouver, but the absolute reduction was approximately the same. Comparing just the manufacturing stages, the percent reduction was approximately 5% (4.6 in Toronto, 4.7% in Vancouver). When compared in the cradle-to-grave scenario, the percent reduction was 1.6 to 1.8% in Vancouver and 0.3 to 0.4% in Toronto.

Other Significant Impact Categories from the LCA Study:

1. The three buildings with the lowest acidification potential in Toronto were the buildings with conventional precast concrete envelope and cast-in-place concrete structural frames (P-C, Pi-C, and Pib-C).
2. The six buildings with the lowest respiratory impact in Toronto were buildings with precast concrete envelopes.

3. The three buildings with the lowest photochemical smog potential in Toronto were the buildings with precast concrete envelope and cast-in-place concrete structural frames (P-C, Pi-C, and Pib-C).
4. Buildings with precast concrete or cast-in-place concrete structural frames had less impact in the water use category than buildings with steel structural frames.
5. Buildings with precast concrete or cast-in-place concrete structural frames had less abiotic resource depletion than buildings with steel structural frames.

The executive summary of the precast structural assemblies, Life Cycle Assessment of Precast Concrete Commercial Buildings, can be found by following this link: http://www.cpci.ca/en/resources/technical_publications/.

The concrete industry is developing and promoting low environmental impact building design, complementing such current efforts as the new Energy Code and ASHRAE's Advanced Energy Design Guidelines to encourage the elimination of thermal bridging in building facades and the increased use of thermal mass.

CHAPTER 5 Detailing for Success

The design of a successful building envelope must consider all of the Performance Criteria discussed in Chapter 4 and must successfully integrate the following functions in a comprehensive design strategy:

- Air control
- Water control
- Vapour control
- Thermal control
- Durability

Architectural precast concrete wall panels have been used successfully as part of an integrated exterior wall assembly and have a proven record of long term performance. All of the above criteria should be addressed in a straightforward and comprehensive design strategy. When this strategy is implemented during the design and construction phases of the project, the likelihood of a successful outcome is significantly improved. Architectural precast concrete wall assemblies provide for expedient construction and successful closure of the envelope. This latter point can be of critical importance to overall project success.

5.1 Design Criteria for Detailing of Precast Concrete Wall Panel Joints

In architectural precast wall design, one of the critical links to a weatherproof building envelope is the joint design and the selection and use of sealants and membranes to ensure the continuity between similar and dissimilar building materials. The design and execution of these joints is extremely important and must be accomplished in a constructible and economical manner. The overall appearance of the project may be affected by the detailing and treatment of the joints. Selecting the right product, appropriate joint design, proper surface preparation, and correct application technique will ensure the joint and sealant provide the desired performance, design service life and pleasing, long term aesthetics.

Joints are required to accommodate changes in wall panel sizes and/or structural dimensions caused by changes in temperature, moisture content, and applied loads while at the same time, prevent water, air and vapour penetration through the building envelope.

Design criteria for joints include the following:

- Exterior exposure (orientation and climatic conditions).
- Structural requirements (amount of movement to be accommodated) such as primary structure creep, inter-storey drift, building sway from seismic considerations and thermal expansion and contraction effects of the panels and the structure.

- Interior climate of the building.
- Architectural appearance.
- Function of the building.
- Construction tolerances.
- Economics.

The decisions that must be made in response to the design criteria include: joint width and depth, type of sealant, location of the joints, number of joints, architectural treatment of the joint, and the selection of materials. See Section 5.3.1.4.

Joint locations should ideally be determined during the design development phase in consultation with the precast manufacturer. Panel size affects joint design and width which, in turn, may dictate location of structural support points and tie backs, and may be further constrained by manufacturing, trucking and erection limitations. Joint design affects envelope performance, allowable construction tolerances, the detail of transitions between adjacent materials, and the details at openings.



Misaligned panels—Alignment of panels directly impacts both aesthetics and joint sealing success.

Source: M.E. Hachborn Engineering

5.2 Precast Concrete Wall Panel: Edge Joint Design

5.2.1 Joints as Architectural Treatment

Joints should be expressed as strong visual features of architectural wall design. False joints (reveals) can also add to the visual effect. The recessing of joints and/or sealants provides many advantages. Recessing the joints or the sealant will assist in diminishing the visual impact of variations in joint width, joint profile and in adjacent surfaces, especially with larger wall panels. In addition, recessing may reduce exposure to ultraviolet light, reducing long term deterioration and potentially extending the life of the exterior exposed sealant. Finally, by recessing the joints, the lateral flow of wind-driven rain over the sealant may be reduced.

Joints are key features that can affect weathering patterns. Vertical joints help in channeling water (provided the joints, sealant or gaskets are not flush with the adjacent precast surface). The concentration of water at recessed joints requires careful detailing to prevent moisture penetration. Complicated edge profiles should be avoided

for economy in manufacturing and reduction of damage during construction. Complicated profiles such as cornices and moldings are more vulnerable to damage in handling and more difficult to repair and make watertight. In addition, it is



Typical joints.

Source: Morrison Hershfield



Transition joints should also be properly aligned. Source: CPCI

important to avoid joints across sloping sills or joints that split window openings as they are very difficult to construct successfully and are susceptible to failure.

Chips along panel edges disrupt water flow which creates opportunities for dirt to concentrate. Suggestions for detailing typical architectural precast concrete panel joints include rounding corners, recessing sealants and avoiding flush sealant joints.

5.2.2 Butt Joints

Butt joints are acceptable in all projects but the treatment of the sealant in these butt joints can have a dramatic impact on the appearance of the project. Placing the sealant flush with the face of the panels is not recommended as it is difficult to keep the sealant within the joint width and even more difficult to maintain the face of the sealant bead flush with the surface of the panels. On projects with smaller or more complicated architectural panels, where variations in panel thickness are difficult to detect or prevent in the manufacturing process, butt joints can create unwanted shadow lines which can appear on the body of the panels, rather than in the joint area. Shadow lines can also be exacerbated if panels bow. Both of these effects can cause an undesirable visual appearance of the panel assembly. In projects using complicated shaped architectural precast panels it is advisable to avoid the use of butt joints unless the panel sizes are relatively small.



Unwanted shadow line at a panel butt joint.
Source: CPCI



Recessed or Reveal Joint. Source: CPCI

5.2.3 Chamfered and Chamfered Reveal Joints

Chamfered joints are a commonly used joint on structural and lower end architectural projects. The joint can accommodate the typical variations due to acceptable construction tolerances on these types of projects. Panel size, thickness and alignment issues can be hidden within the joint due to the offset of the sealant profile and the wide visible joint line. Variations in width are less noticeable due to the overall width of the joint relative to width of the sealant bead, and the depth of the joint sealant profile, recessed beyond the chamfer. The recessing of the sealant bead within the joint recesses reduces joint sealant exposure and channels runoff. The chamfer on the panel edges also reduces the chances of incidental panel edge damage caused by rough handling or shipping. Chamfered joints are not normally used with high end finishes which require sharp crisp corners.

5.2.4 Recessed or Reveal Joints

An excellent architectural treatment of joints for custom architectural precast panels is the placement of a reveal along the edge of the panel, creating what is referred to as a recessed or reveal joint. A slight slope on the sides of the reveal, called draft, is required for neat and precise reveal formation. Reveal joints are preferred as the detailing and construction can be more precise than chamfered joints and they can be designed to the same profile as the reveals in the remainder of the panel. Recessed or reveal joints can accommodate the tolerances required for panel

thickness, but more importantly the shadows formed within these joints minimize any adverse effects on the aesthetic appearance of the panel and joint system. As with the chamfered joint, making the joint appear wider than it actually is, the variations are proportionately reduced, and tend to make the differences more difficult to detect. The depth of the reveal tends to mask slight misalignment in the panels at the joints and by slightly recessing the sealant, the profile of the joint can be concealed. The cut away portion of the edge of the panel for the reveal also reduces the chances of panel edge chipping.

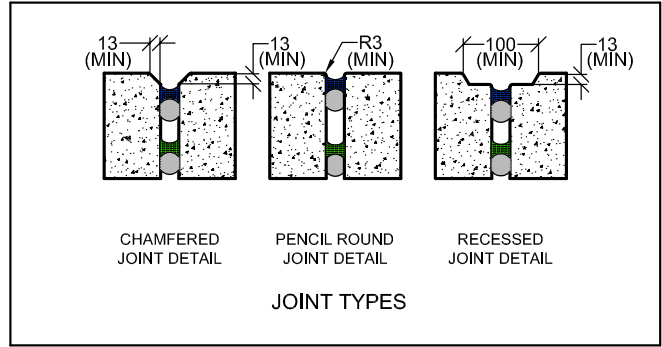

Figure 5-1: Joint Types.
Source M. E. Hachborn Engineering

5.3 Precast Concrete Panel Joint Design

5.3.1 Sealant Joints for Single Wythe Wall Panels

Based upon the principles of a drained assembly, sealant joints for single wythe precast concrete wall panels should employ the two-stage joint configuration, with an inner air seal and an exterior weather seal. The inner seal also serves as the second line of defense against moisture ingress. The space between the inner and outer seals is vented to drain any moisture that penetrates the weather seal to the exterior (See Chapter 4).

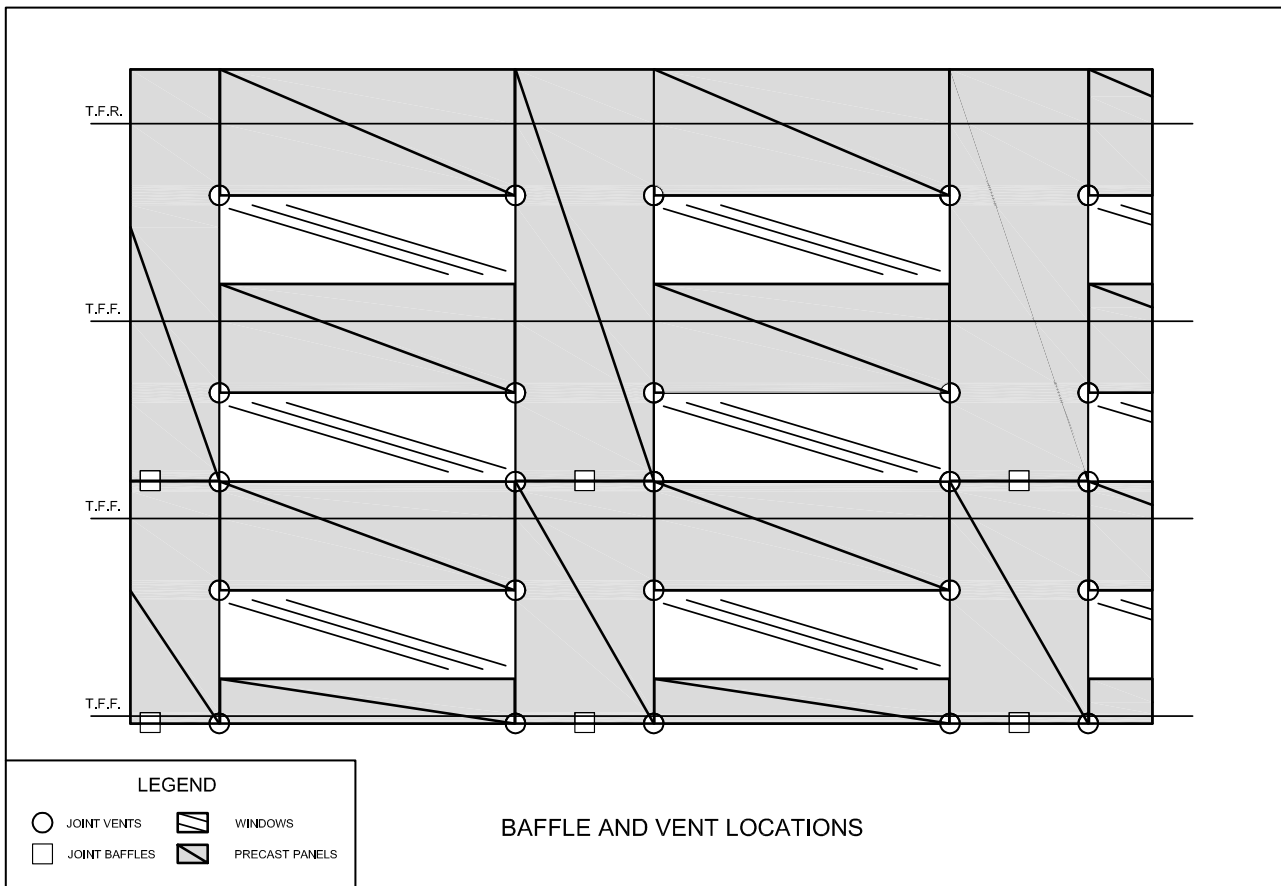

Figure 5-2: Detail of Transverse Baffle Joint Locations. Source: M.E. Hachborn Engineering

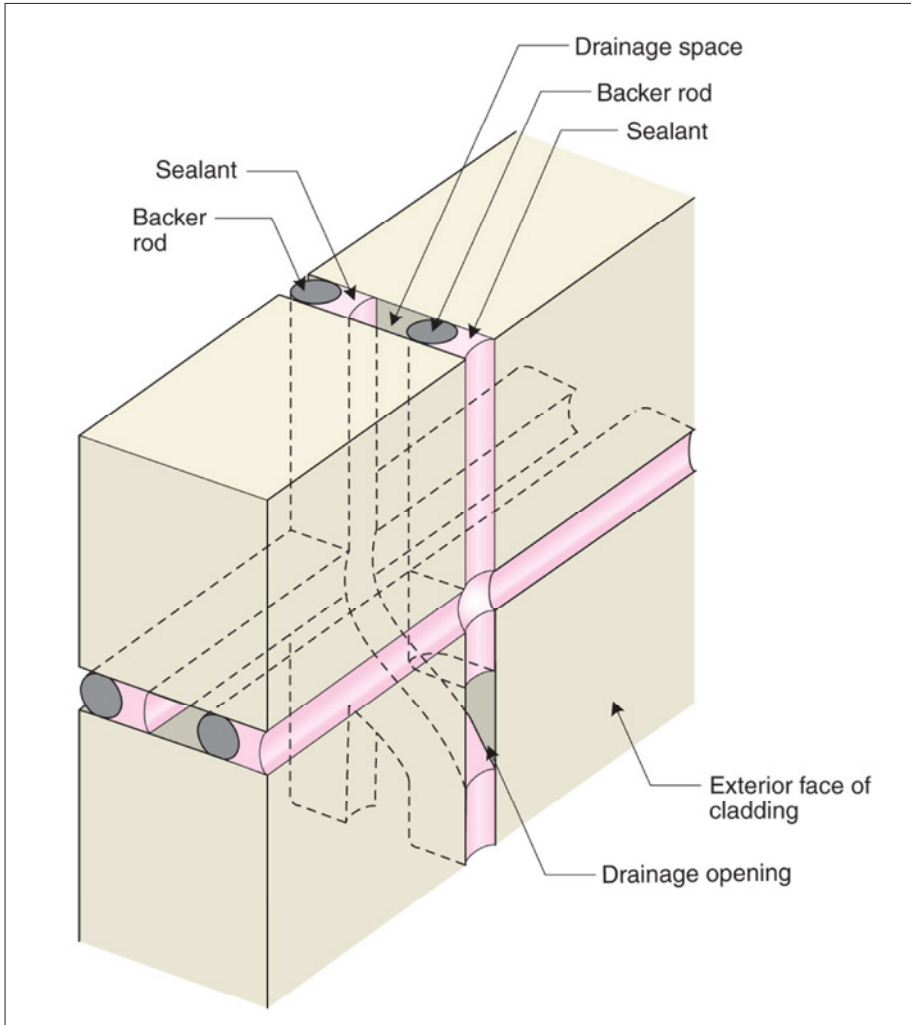

Figure 5-3: Details of a two-stage joint at a drainage/vent hole. Image copyright RDH Building Science Inc., used with permission

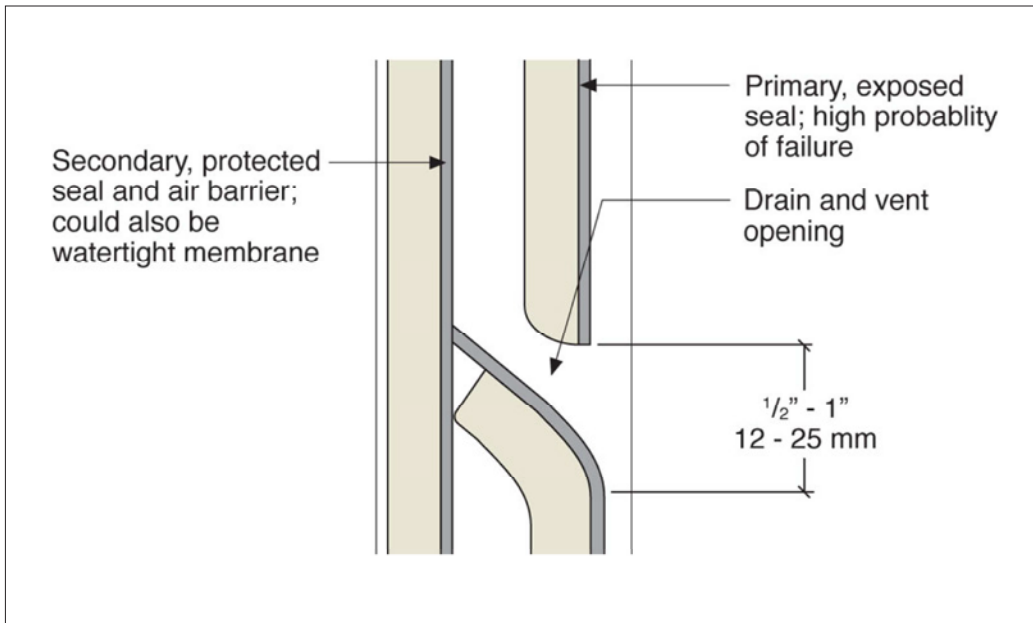

Figure 5-4: Details of a two-stage joint at a drainage/vent hole. Source: Image copyright RDH Building Science Inc., used with permission

Drainage is generally achieved by transverse sealant installation in concert with the vent location. These transverse sealant installations also serve to vertically compartmentalize the panel joints and avoid the vertical movement of air in the gap between sealant beads caused by wind, outside air turbulence and stack effect. The transverse sealant detail should be installed at regularly spaced intervals along the height of vertical joints, typically 300 mm to 600 mm below or just above the junction of the horizontal and vertical joints. Thus, any moisture that does accumulate inside the joint will be lead out of the system promptly and run down the face of the joint sealant and not inside the joint or over the face of the panels. Transverse baffles should also be provided in the horizontal joint at the mid span of the panel in order to prevent the horizontal movement of air within the joint space caused by differential air pressures around the building due to wind.

Single wythe wall panels used in drained wall assemblies may sometimes employ the single stage joint system, however this is only encouraged for systems utilizing small handset panels (See Section 2.2.2).



*Vent and weep opening in sealant.
Source: M. E. Hachborn Engineering*

5.3.2 Sealant Joints for Double Wythe Insulated Wall Panels

In double wythe insulated precast concrete wall panels, the inner sealant bead is installed at the front face of the interior structural wythe. This placement prevents cold exterior air from coming in contact with the warm interior wythe. The caulking contractor should install both the interior and exterior sealant beads from the outside, and this should be indicated on the drawings. To install the interior bead, the joint needs to be sufficiently wide to accommodate the extension nozzle required for placement of the inner seal. While the interior face of the interior wythe (room side of the interior wythe) is sometimes caulked for construction reasons to close in the building for finishing purposes (referred to as the construction seal), it is optional and not necessary for proper performance of the two-stage joint system.

Key considerations and best practices include:

- Concise joint details should be shown on the architectural, shop and construction drawings.
- Continuity of the air seal must be carefully considered in three dimensions during design to make sure the intended connections with other elements can actually be constructed.
- The two-stage joint concept requires good planning to install and inspect.
- The inner seal should be inspected prior to the installation of the exterior seal as it will be hidden from view once the exterior weather seal is installed and the interior seal is the primary seal dictating the performance of the envelope.
- The exterior weather seal prevents direct water entry.
- The interior air seal is protected from the deteriorating effects of ultraviolet light, direct wetting and temperature extremes by the exterior weather seal, leading to longer service life. It also acts as a secondary water seal when joined to the transverse seal which is tooled to the exterior at the vent locations just below the horizontal panel joints and at the base of panels. This interior air seal is exposed to a much reduced extension / compression requirement due to the relatively constant temperature of the interior wythe.

from the joint cavity down the sealant lines and controls panel staining. Joint vent openings should be the full width of the joint and 25 mm high. The use of vent tubes to create the opening is not recommended as they constrict the opening, fill with insects and may create accumulation of water at the tube / sealant interface inside the panel joint.

- Baffles should also be installed in the horizontal joints at mid span of the panels to prevent the horizontal movement of air in the joint space due to pressure differentials around the building caused by wind. When drained precast panel assemblies are employed (not recommended), the placement of baffles does not achieve the desired result as the air can pass the baffles by moving through the drainage layer. See Figure 5-2.

5.3.3 Preferred Sealant Installation Practice

It had been common practice in the past with architectural precast concrete wall panels that the interior seal be placed from the building interior. This is not recommended and is now discouraged as experience has shown that many portions of the interior joint are not accessible from the interior and attempts to make the seal continuous were not successful. Panel configuration and joint sizes should permit a careful applicator to successfully install both the air barrier/vapour retarder seal and the weather barrier seal from the exterior of the building. For proper installation of the interior seal from the outside, special tools are required which include rollers, depth gauges, an extension nozzle on the caulking gun and longer and specially shaped tools for tooling the interior seal.

If the interior seal is installed from the interior, considerable expense is added to properly complete the interior seal because all interruptions such as panel-to-panel plates, bolts and washers need to be sealed tight to prevent the transfer of air and moisture and the seal must be completed at the roof line.

For large industrial type modular prestressed panels, the interior face is often left exposed and will span from the foundation to the roof. In these applications, installing an additional interior seal referred to as a construction seal may be desirable to reduce dirt accumulation in the joint.

The architect, building science consultant, precast concrete manufacturer, erector, and sealant applicator must all understand the function of the two-stage drained joint if optimum results are to be achieved. The most common mistakes made in the installation of two-stage joints are; leaving gaps in the air vapour seal, making the exterior weather seal airtight, and/or improperly venting or draining the drained joint space. It is advisable to have a meeting with the sealant subcontractor and all workers to be employed by the sealant applicator on the project prior to any sealant being applied to ensure that all are aware of the details required and the consequences of failing to follow these details, including costs to remove and reinstall incorrectly installed sealant to the specified details.



Interior-applied air/vapour sealant bead installed at panel joints and at panel connections. This is costly and not recommended. It is better to seal all joints from the exterior. Source: CPCI

5.3.4 Joint Sizing and Sealant Selection

Elastomeric sealants are installed at the joints between precast concrete panels as well as the interface of precast wall panels and other cladding elements such as windows, doors, foundation walls, shear walls and floors slabs.

Correct joint width is influenced by the size of the adjacent panels on either side of the joint, the distance to the point of fixity of the panels from the joint in question, the material properties of the panels and the sealant used,

and the temperature at which the sealant is applied. Joint width is also influenced by the climatic conditions, the structural loadings, and environmental loads such as wind and seismic conditions.

- Joint width (J_w) resulting from panel movement due to thermal fluctuations can be calculated with the following simplified formula:

$$J_w = (100/S_m) \times C_t \times \Delta T \times L$$

such that,

S_m = sealant movement capacity, in per cent

C_t = coefficient of thermal linear expansion (typical value for concrete 14.5×10^{-6} m/m/°C (8×10^{-6} in/in/°F))

ΔT = the range of maximum to minimum temperature, in °C or °F

L = effective panel length or height for movement considerations (in millimetres or inches). This length is normally assumed to be the length of the largest panel but should theoretically be the largest distance between the points of fixity of two adjacent panels.

Similar calculations can be carried out for the effects of expansion/contraction due to moisture absorption in the precast panels, frame deflection/shortening as well as creep if it is a concrete structure. Construction tolerances and seismic considerations should also be addressed, in consultation with the building structural engineer. Most panel configurations will likely defer to the minimum joint sizes (presented below) that account for construction tolerances, as well as minimum application width for sealant installation.

The minimum joint sizes that can be installed effectively, efficiently and with a good chance of achieving the published sealant service life are as follows:

- $J_w \geq 20$ mm (3/4 in.) (single wythe precast concrete panels)
- $J_w \geq 25$ mm (1 in.) (double wythe insulated precast concrete panels)
- Corner joints may be 30 mm wide to accommodate the extra movement, bowing and panel expansion often experienced at these locations.

These minimum, nominal joint widths also account for construction tolerances. Construction tolerances allow for variations in precast panel size as well as variations in site dimensions related to structural frame construction, member sizes and trueness of the structure to the

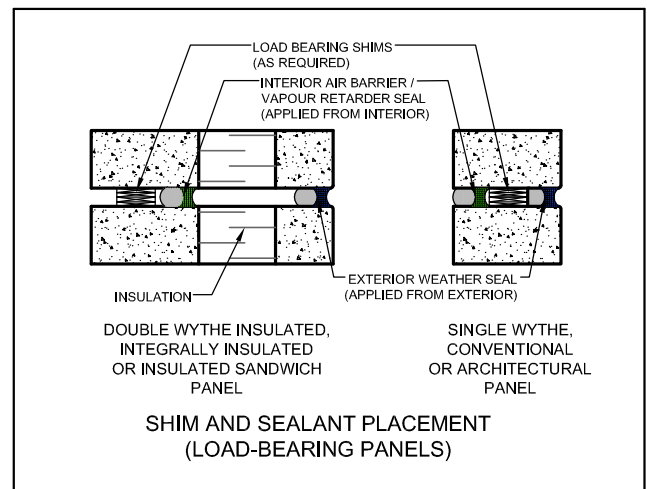

Figure 5-6: Proper Joint Sealant Profile.
Source: M. E. Hachborn Engineering

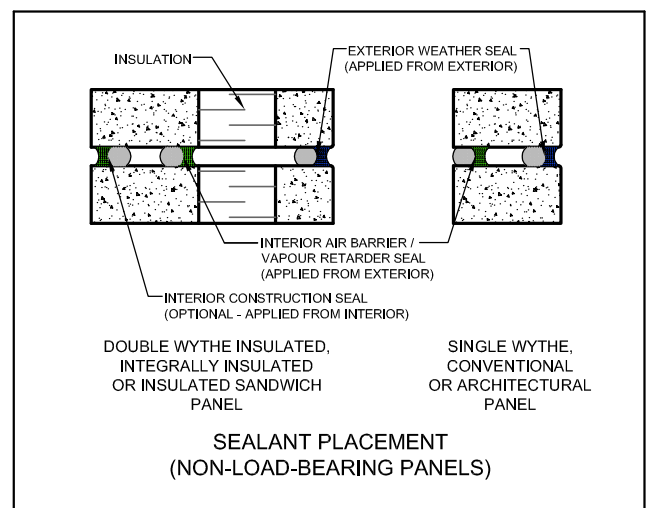

Figure 5-7: Proper Joint Sealant Profile.
Source: M. E. Hachborn Engineering

theoretical lines and dimensions. It is prudent to assume that any joint could have a tolerance of ± 6 mm ($\pm 1/4$ in.). If the joint were to be up to 6 mm narrower than shown on the drawings, the joint sizes for single and double stage joints would become a minimum of 13 mm ($1/2$ in.) and 19 mm ($3/4$ in.), respectively.

The key factors for determining the profile of sealant joints include:

The thickness of sealant at the centre of the sealant bead should be half the joint width. The thickness of the sealant bead at the interface with the concrete or other material at each end should be between $3/4$ and 1 times the joint width. This profile allows the sealant to stretch and compress without causing undue stress in the body of the sealant bead (cohesive failure) and along the edges of the sealant bead to the adjacent materials such as the precast or windows (adhesive failure). The proper joint profile should be slightly concave on the surface to allow for a flush surface when the joint closes and the sealant is compressed. The back face of the sealant is formed to a concave profile by the backer rod. See Figure 5-7.

The sealant must be installed with a closed cell backer rod, typically polyethylene or polyurethane foam. The backer rod serves as a bond breaker, as well as providing a substrate for tooling the sealant to the proper sealant profile. The backer rod should be 25 per cent larger diameter than the joint width to ensure it is under compression once placed into the joint and remains in place when the sealant is tooled. The backer rod should be located at a consistent depth to ensure the proper sealant profile while providing a smooth and uniform face for aesthetics. The sealant bead should also be carefully tooled without causing the sealant to push the backer rod out of place. Proper sealant tooling is critical to ensure that the sealant is formed to the desired profile and the sealant is well bonded to the precast concrete panels on both sides and for the entire length of the joint.

5.3.5 Structural Expansion (Contraction) Joints

Expansion joints must be designed for long term weather protection, for the appropriate movement, and for appearance. In most cases this requires that special gasket materials be used, rather than sealants. The requirements for expansion joints are otherwise similar to those listed above for normal panel to panel joints.

Specially designed expansion joints generally accommodate cumulative movements of large portions of a structure, as well as differential expansion movement of adjacent wall materials. Joints should be designed to be as simple as possible since an expansion joint may have to accommodate considerable movement. Although these requirements may result in an appearance somewhat different from a normal joint, architects should consider function over form for these situations.

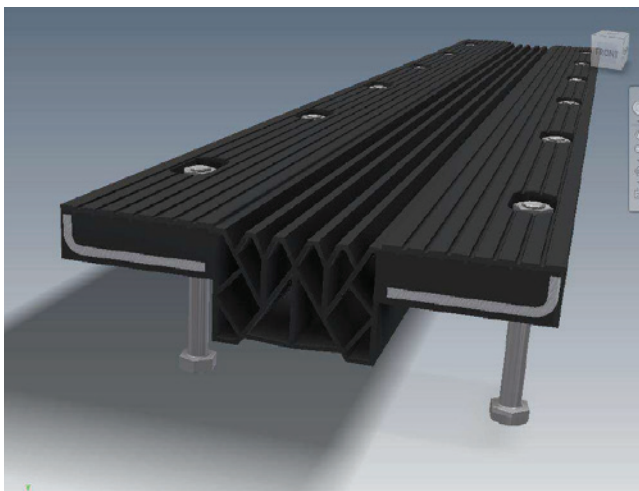

Bellows-type expansion seal. Source: WBA Corp.



Expandable foam expansion joint material. Source: Emseal Corp.

Materials for expansion joints must be chosen for their ability to absorb appreciable movement while maintaining their primary function of controlling the movement of moisture and air. Bellows-type expansion seals and expandable foam products can be sized to accommodate a wide range of joint widths.

The joint width should be increased where neoprene or other gasket or compression seals are used.

5.3.6 Seismic Storey Drift and the Effect on Joint Widths

In structures built in seismic zones, inter-storey drift can have a significant effect on the joint width. When the joints are required to accommodate these seismic inter-storey drift values and remain functional following the design event, joint widths are increased in order to stay within the allowable movement range of the sealants.

The larger the seismic inter-storey drift, the larger the joint width when full storey height panels are used. This may require the joints to be sized beyond the recommended maximum joint width for the given sealant material. In these cases, other materials, such as seismic seals, may be utilized to accommodate the required movements.

When panels are supported on one level, the panels move as a unit and joint widths are not affected by seismic drift. However when the panels are supported at various levels, seismic drift needs to be considered in determining the appropriate joint width. This is also true for panels that meet at perpendicular runs, or panels that interface structural components such as columns, shear walls or stair wells and elevator shafts.

Joint width for seismic drift must be sized using the sealant movement ratios to accommodate the drift as well as other considerations such as thermal movement of the adjacent panels.

Seismic seals are a special class of expansion joints in which the joints are generally quite large. They are commonly used between new and existing construction and maintain the integrity of the building envelope while permitting the structures to move from thermal expansion, wind drift and seismic motions without damage. Seismic joints are designed to accommodate both vertical and horizontal movement.

5.3.7 Sealant Selection

The choice of sealant material is the most important factor affecting the long-term durability of the precast concrete wall panel system. Typically more than one type of sealant can meet the primary performance requirements of a particular project.

Primary performance requirements include:

1. Adhesion and compatibility with the substrates,
2. Accommodating anticipated joint movements, and
3. Delivering the required durability and aesthetics over the expected service life of the sealant.

Selecting a durable sealant which will tolerate the environmental stresses (expansion and contraction of panels, ultraviolet exposure, temperature cycling, continuous wetting and drying, etc.) is critical to minimize future maintenance requirements. As such, in the sealant selection process, the emphasis should always be on sealant durability, rather than on initial material cost. The additional cost for a superior sealant will be a small portion of the total cost of the building, and should always preclude the use of cheaper sealants chosen solely on price. The cost of replacing the sealant is far greater than the added cost of choosing the best available product at the time of construction.

Key considerations when choosing a sealant:

- The typical sealant materials used for precast concrete panel joints are polyurethanes (single and multi-component), single component silicones and hybrids (a combination of silicones and polyurethanes). Although polysulfide sealant was widely used in the past, it is not common today.

Of the three types in common use today, silicones and hybrids are preferred, as they are better able to tolerate high temperatures, ultraviolet radiation and have a higher range of installation temperatures as well as providing superior durability and service life.

- Care must be taken to avoid sealant bleeding into porous substrates.
- Acetoxycure sealants should be avoided, due to chemical incompatibility between the sealant which is acidic and the concrete which is basic, resulting in poor bond to the precast concrete substrate.
- Product data sheets provide typical guidelines on adhesion to most common substrates. While many sealants are compatible with concrete, the compatibility, adhesion, cleaning requirements and need for primer should always be confirmed, in writing, with the manufacturer before specifying a product.
- Sealants are either a neutral (atmospheric moisture) cure or solvent cure material. The compatibility of a specific sealant with all other sealing products to which they will be required to adhere to should be reviewed during the construction mock-up stage of a given project to ensure that incompatibility is avoided prior to installation.
- If different sealants are applied to or come in contact with each other, it is necessary to review the order of construction and the compatibility of sealants curing at the same time. The designer therefore must select and coordinate all of the sealants used on a project for chemical compatibility and adhesion to each other. In general, contact between incompatible sealant types can be avoided by having one sealant contractor perform panel and window sealant application with the same sealant material.



Sample testing of installed sealant to confirm proper dimensions. Source: Morrison Hershfield



Sample testing of installed sealant to confirm proper dimensions. Note sealant bead is far too thin in this instance. Source: Morrison Hershfield



Sample testing of installed sealant to confirm proper dimensions. Bead is far too thin at the center, and bond edges are too narrow in this instance. Source: Morrison Hershfield

- The application conditions are critical. High relative humidity and moisture within the concrete panels may lead to premature adhesion failure of the sealant to the precast substrate. It is important to ensure that the surfaces are dry, and the air and substrate temperature at the time of application are within the manufacturer's recommended range. Priming must also conform to the sealant manufacturer's requirements.
- Single component polyurethanes, hybrids and silicones should comply with the requirements of CAN/CGSB 19.13-M87, "Sealing Compound, One Component, Elastomeric Chemical Curing" (CGSB, 1987). Multi- component polyurethanes should comply with the requirements of CAN/CGSB 19.24-M90, "Multi-component, Chemical-Curing Compound" (CGSB, 1990). The following material properties and requirements should be incorporated into the 07900 specification for sealants applied to precast concrete joints:
 - ◆ Panel edges must be clean, dry and free of any deleterious material that may affect the adhesion of the sealant. The sealant should be allowed to cure without direct exposure to precipitation.
 - ◆ Sealant movement capability should be at least 25 per cent or as required by the design movement parameters determined for the specific application in relation to the joint size.
 - ◆ Sealant materials should have demonstrated performance capability, in terms of adhesion and elasticity, after testing for 2,000–5,000 hours of ultraviolet, accelerated exposure, according to ASTM C793, the Standard Test Method for Effects of Laboratory Accelerated Weathering on Elastomeric Joint Sealants (ASTM, 2010).
- Sealant tensile adhesion can be tested in accordance with ASTM C1135, the Standard Test Method for Determining Tensile Adhesion Properties of Structural Sealants (ASTM, 2011). Adhesion in peel can be tested in accordance with ASTM C794, the Standard Test Method for Adhesion-in-Peel of Elastomeric Joint Sealants (ASTM, 2010).
- Most sealants are manufactured and supplied with compatible proprietary primers. The necessity for primer application can be determined by field testing for sealant adhesion. A simple method for determining the adhesion of a specific sealant for application into a given joint would be to create a construction mock-up that would also incorporate other critical building envelope details, and include a typical sealant joint. Once the sealant is cured, cut the sealant at each side of the joint—100 mm (4 in.) long—and at the top. Pull out the sealant to review its profile, noting the dimensions. Then pull on the sealant at a 45-degree angle of incidence from the wall plane. The sealant should not fail in adhesion or cohesion before the sealant reaches its design movement capability.
- Elasticity can be measured by testing in accordance with ASTM D412, the Standard Test Methods for Vulcanized Rubber and Thermoplastic Elastomers – Tension (ASTM, 2013).
- Joint movement capability is tested to ASTM C719, the Standard Test Method for Adhesion and Cohesion of Elastomeric Joint Sealants under Cyclic Movement (ASTM 2013).
- Field adhesion tests using ASTM C1521 Standard Practice for Evaluating Adhesion of Installed Weatherproofing Sealant Joints (ASTM, 2013). These tests will determine the adhesion of the sealant with each contact surface.
- Most hybrid, silicone and polyurethane sealants are suitable for precast concrete panel joints provided they have a medium to low modulus of elasticity.
- Sealants that have the potential to cause staining tend to be silicone-based, with a high content of oils that can leach out of the sealant over time. If staining of the substrate is a concern, then one of two tests can be conducted: ASTM C510 Standard Test Method for Staining and Color Change of Single or Multi-component Joint Sealants (ASTM, 2011) or ASTM C1248 Standard Test Method for

Staining of Porous Substrate by Joint Sealants (ASTM, 2012).

- Sealants are available in an assortment of colours. However, the neutral colours tend to provide less noticeable accumulation of dirt and/or fading. Sealant manufacturers should be consulted on the application proposed. They should provide testing services including for adhesion and staining of the substrate as well as certification that the sealant was installed according to their requirements and the appropriate warranties.

Early testing will prevent most problems. Performing these evaluations early in the project schedule prior to the sealant application being required provides a method for obtaining feedback on installation workmanship and modifications can be implemented before commencement of sealant application on the building.

ASTM C1521 (ASTM, 2013) provides guidance for two tests. The first is non-destructive and consists of applying pressure to the surface of the sealant at the center of the joint, and the bond line, with a probing tool. The second procedure involves removing sealant to evaluate adhesion and cohesion. This test offers 'tail' and/or 'flap' procedures, depending on whether similar or different substrates are present on adjacent surfaces of the sealant joint. Applying new sealant to the test area should repair the sealant pulled from the test area. Assuming good adhesion was obtained, the applicator will then use the same application procedure to repair the areas originally sealed. Care should be taken to ensure that the new sealant is in contact with the original sealant so that a good bond between the new and old sealants will be obtained. ASTM C1521 can be used to evaluate installed sealant during mock-ups, at the start of work to confirm application methods, and throughout the work to confirm installation consistency. It provides guidelines for the frequency of destructive testing when evaluation is part of a quality assurance program for a new installation. All results should be recorded, logged and sent to the sealant manufacturer for warranty issuance.

In addition to the above standard, ASTM C1193, the Standard Guide for Use of Joint Sealants (ASTM, 2013) can be of use to the designer and sealant installer, as it provides guidelines on the properties and functions of various materials and procedures for cleaning, priming and sealant application, considering environmental conditions during installation that may impact the sealant performance. Ultimately, the manufacturer's requirements must be consulted and adhered to in order to achieve the expected performance and keep the manufacturer's warranty valid.

A list of recommended sealant products for performance and quality in precast panel joints is available from precast manufacturers. It is very important to involve the sealant manufacturer in the product selection process for each project such that proper adhesion testing can be conducted and appropriate requirements can then be added to the specifications. Sealant testing by manufacturers for compatibility, adhesion, and to assess the risk of staining is always recommended. In addition, field testing is also highly recommended to ensure proper joint installation.

5.3.8 Joint Preparation

The edges of precast concrete wall panels and the adjacent materials must be sound, smooth, clean, and dry prior to sealant application. They must be free of frost, dust, laitance or other contaminants that may affect adhesion such as form release agents, retarders, or sealers. These contaminants must be removed by sandblasting or grinding prior to sealant application to ensure good adhesion to the precast concrete. It may be more economical and effective to prepare joint surfaces at the manufacturer's plant prior to shipping and installation if a large number of units require surface preparation.

5.3.9 Primers

Some sealants require primer on all substrates while others require primer for specific substrates or none at all. Absence of a required primer will cause premature sealant adhesion failure. Primers often help sealant adhesion in cold weather and are recommended by the sealant manufacturer for the following reasons:

- To enhance adhesion of sealants to porous surfaces or to reinforce the surface.
- To promote adhesion of sealants to surfaces such as porcelain enamel, unusual types of glass, certain metals and finishes, and wood.
- To promote adhesion of sealants to an existing surface treatment that is difficult to remove or to other sealants that resist adhesion once fully cured.

Special care should be exercised to avoid staining the visible face of the precast concrete unit since some primers leave an amber colour when brushed along the surface. This staining, if present and noticeable, will have to be mechanically removed at additional cost.

Primer should be allowed to cure before application of the sealant, and generally the sealant must be applied the same day the surfaces are primed. It is recommended, for compatibility, that the sealant and primer should always be supplied by the same manufacturer.

An important basic fact is that primers will almost always result in better sealant adhesion and long-term durability. All parties, including the architect and the owner must be consulted in any discussion to delete the primer. This must only be done after careful consideration of the trade-offs between initial construction cost and long-term durability, maintenance and repair costs.

5.3.10 Cold Weather Sealant Applications

The application temperature of sealants can be a critical factor affecting their performance, and in particular, their adhesion to the substrate. For many sealants, the application temperature is limited to a minimum of 4°C. Special measures may be available for application at colder temperatures. For high performance sealants, this is modified to include temperatures as low as -29°C (-20°F). It is however recommended that joints be sealed when the substrate surface is cool (spring and fall) and will experience minimum temperature change, typically in the late afternoon or early evening. Large daily temperature swings during curing (warm days, cold nights) may cause adhesive failure and unusual and inconsistent joint profiles. Minimum storage temperature requirements may also apply.

The other consideration with cold weather sealant application is the range of movement the sealant will be required to resist. When the joint is sealed in colder weather, the sealant joint will experience more compression than tension as the substrate will have a higher expansion movement than contraction movement which will cause the joint to narrow more than it will widen. Although this reduces the adhesion forces required to maintain contact with the sides of the joint, the sealant may bulge more than anticipated and if the joints are at the lower tolerance of width, the sealant could be crushed in the joint.

Problems during cold weather application, such as difficulty applying the sealant or poor bonding to the substrate, can be related to the following three situations:

- The substrate may be covered with frost or a thin film of ice that is often too thin to be seen. This can be caused by humidity condensing on the surface of the substrate as a result of the breathing of installation personnel or the leaking of warm moist air from the interior of the building.
- The sealant may be too cold to properly wet the substrate.
- The sealant may be too stiff to “gun” or tool at extremely low temperatures.

Of these, the thin film of ice presents the biggest challenge. The others are overcome by warming the sealant to the temperature range recommended by the manufacturer prior to installation.

When sealant is applied to a substrate at temperatures below 0°C (32°F), even if the ice or frost is melted, the resulting film of water will remain and act as a separator, and then simply freeze again. The application of sealants to wet substrates is never recommended.

One advantage of a construction seal being used during colder periods is the reduction in the accumulation of condensation and frost in the joints due to warm moist air flow through the joints when the building is temporarily heated while under construction. It is also done when the backs of the panels are exposed to view and thereby prevent the accumulation of debris in the joint space.

Proper sealing applications can be achieved at low temperatures if proper care is taken. Since a clean and dry substrate is fundamental to achieving good adhesion of a primer or sealant, once the ice is melted and the surface dried, the substrate can be cleaned with acetone or methyl ethyl ketone (MEK), or wire brushing the surfaces immediately before application, making sure to clean the surface of any resulting dirt, dust and debris. Refer to specific product data sheets for further surface preparation instructions. All of these procedures require additional expense by the sealant applicator and must be allowed for if the sealant is to be applied in less than ideal conditions.

To rush the sealant application in less than ideal conditions to gain a few days in schedule is not advisable and may result in a less than ideal sealant application and possible sealant failure in the future. It is important that all parties be aware of the potential for sealant failure if the installation is rushed and not applied in proper conditions.

5.3.11 Other Considerations

The surface finish requirements of the panel may also influence joint details. Sealant must be applied to a relatively smooth surface since it is difficult to tool the sealant to achieve intimate contact with an irregular surface. For example, with exposed aggregate surfaces, the sealant must be set back from the face of the exposed aggregate such that the portion of the matrix

along the joint presents a smooth, clean surface for the application of the sealant. This is particularly true when interfacing with windows and can be ensured when the design includes recessed external joints. When exposed aggregate surfaces meet at an inside corner special attention must be paid to the joint details and to the finish. Sealants should not be applied to beveled or chamfered surfaces but should be applied beyond the beveled area at the smooth surface. Sealant should be applied to parallel surfaces to create a consistent width of sealant joint. This will ensure that the sealant stresses are uniform across the sealant profile, reducing the chances of cohesion and adhesion failure. V-shaped joints are prone to failure due to the uneven stresses across the sealant bead.

All reveals that return into window and door openings should be stopped short of the sealant bead location to ensure a continuous bead of sealant along the edges of the window and/or door frame. The same applies to reveals at interfaces with other materials. The straighter the sealant bead line, the more likely the bead will be constructed properly and perform as intended.



*Do not carry exposed aggregate into joint location.
Source: CPCI*



*Do not carry exposed aggregate into joint location.
Source: CPCI*

5.3.12 Sealant Backer Rod

Proper selection, sizing and use of backing material (backer rod) is essential for the satisfactory performance of watertight joints. For sealants to perform to their optimum movement parameters, they must not adhere to the backer rod. Sealant backer rod materials such as closed cell expanded polyethylene, open cell polyurethane, or non-gassing polyolefin are recommended for horizontal and vertical joints with a minimum of 25% compression of the backer rod.

It is critical to have adequate compression of the backer rod to ensure the backer rod will remain in place in the joint and not be dislodged or moved during sealant installation and tooling. Joint backer rod must remain under compression at all stages of joint movement, to ensure support for the sealant bead. When inserting polyethylene backer rod, a blunt tool or roller should be used to avoid skin puncture of the backer rod and possible off-gassing, which may cause blistering of the sealant. In addition, the joint backing must be thoroughly dry. Only backing material that can be covered with sealant in the same day should be installed in the joints.

5.3.13 Installation and Tooling of Sealants

Sealant installation should be specified to meet the requirements of ASTM C1193 (ASTM, 2013). The sealant manufacturer should always be consulted regarding mixing, surface preparation, priming, application procedure, and life expectancy of the sealant. In addition, application by a qualified sealant applicator is one of the most important factors for satisfactory performance. Caulking guns should have a nozzle of proper size and should provide sufficient pressure to completely fill the joint in one pass. Joint filling should be done carefully and completely, by thoroughly working the sealant into the joint since under-filling of joints normally leads to adhesion failure. After joints have been completely filled, they should be neatly tooled to ensure adequate adhesion, create an adequate profile, eliminate air pockets or voids, and to provide a smooth sealant bead. Tooling provides a slightly concave joint surface which improves the sealant configuration and performance, and achieves a visually satisfactory finish even when the joint has closed due to panel expansion. Joint tooling should be performed within the allowable tooling time limit for the particular sealant as recommended by the sealant manufacturer to ensure the sealant bead does not wrinkle and become unsightly. The final surface of the sealant should be full, smooth, free of ridges, wrinkles, sags and air pockets, and any embedded impurities.



*Loose backer rod. Backer rod too small for joint size, resulting in improper sealant application.
Source: Morrison Hershfield*



*Loose backer rod. Backer rod too small for joint size.
Note also that improper panel alignment has resulted in a wide range of panel joint sizes.
Source: Morrison Hershfield*

Dry tooling is the only acceptable method for creating a proper sealant joint. Tooling solutions such as water, soaps, oils, or alcohols should not be used unless specifically approved by the sealant manufacturer since they may interfere with sealant curing and adhesion, and may also create aesthetic issues.

Uncured silicone or polyurethane sealants should never be allowed to contact surfaces such as polished granites, metal or glass. During installation these surfaces must be masked, or care taken to prevent sealant contact since excess sealant cannot be completely removed with organic or chlorinated solvents. Once a sealant contacts an exposed surface, it will leave a film that may change the aesthetic surface characteristics of the substrate. Surfaces contaminated with sealant materials should be cleaned as work progresses, since removal is likely to be more difficult after the sealant has cured. A solvent or cleaning agent recommended by the sealant manufacturer should be used to remove sealant where not desirable.

5.3.14 Durability of Sealants

While sealant life varies by product type and cost, the durability of the sealant used should be weighted heavily to ensure a substantial service life. Manufacturer warranties should always be consulted. Once a sealant has reached 50% of its life expectancy, joints should be routinely inspected for potential degradation and possible failure, and be repaired promptly as required. Silicones have the longest warranties of the commonly used products.

The actual sealant material cost typically represents less than 25 percent of the installed cost of the sealant. The sealant contract typically represents less than 10 percent of the waterproofing costs of a structure and waterproofing of the structure typically represents less than 5 percent of the total cost of the structure. The decision to use the best sealant available may represent a 50 percent increase in the cost of the sealant material, amounting to less than 0.06 percent of the overall project cost but may increase the service life of the sealant from 5 to 25 years and reduce the maintenance costs significantly. On a \$50,000,000 project the additional costs would represent \$30,000 or \$1,200 per year over the 25 year service life. However, the replacement cost of the sealant in 5 years would be in the order of \$500,000. From an economics perspective, the use of the best sealant available is simply the only way to proceed.

5.4 Details Overview

The details that follow illustrate architectural precast concrete assemblies in many different configurations, and when interfacing with other assemblies. Each plan or section detail displays the various components normally associated with typical Canadian and North American construction.

These details do not address all possible situations that may arise, rather they include a selection of precast panel types and junctions that can occur on typical buildings. These details illustrate the application of the design principles previously discussed. The designer can determine the details required for their specific application from a review of those illustrated here.

The particular design parameters are subjective. Each building design requires an analysis of its unique set of conditions. Each building has a different combination of interior environment, exterior exposure, desired esthetics and service life, all of which have an impact on the building design. One common feature is that the design must



Good quality sealant joint between precast panels. Source: CPCI

be constructible, which means that the materials and the sequence of construction must be considered as part of the design process.

The following parameters are common to all details:

- The panels are non-load bearing from a primary building structure perspective except details 4A, 4B, and 14A.
- The panels are assembled with two-stage joints, which consist of a “weather seal” installed at the exterior face of single wythe wall panels or double wythe insulated wall panels, and an “air seal” installed at the interior of single wythe wall panels or at the outer face of the inner structural wythe in double wythe insulated wall panel construction. The line of the weather seal and air seals in the panel joints beyond the panel sections is shown as a dotted line and identified as a bold blue and green solid line respectively in each section.
- Generally, the “weather seal” and “air seal” are installed from the exterior for continuity of application. When continuity problems around columns, floors and anchors can be avoided, installation may effectively be completed from the interior.

It is important to understand that these details are intended to illustrate possible configurations for typical construction. They are not intended for any specific project and the designer, precaster, authority having jurisdiction, and contractor must ensure that the actual panel and wall assembly reflects the following;

- The intended use of the facility
- The local climate
- Building, fire, and energy code minimum requirements
- Aesthetic requirements
- The owner’s project specific requirements
- Local construction market capabilities
- Reasonable design practice

The details are divided into two main sets, one for single wythe precast concrete wall panels and one for double wythe precast concrete insulated wall panels. For each detail, a description is provided that indicates the materials providing the major building envelope performance characteristics:

- Precipitation management (indicated by a bold blue line)
- Air barrier (indicated by a bold green line)
- Heat flow management (indicated by a varying width yellow line, the width representing the relative thermal performance at that point)
- Vapour management (indicated by a bold purple line)

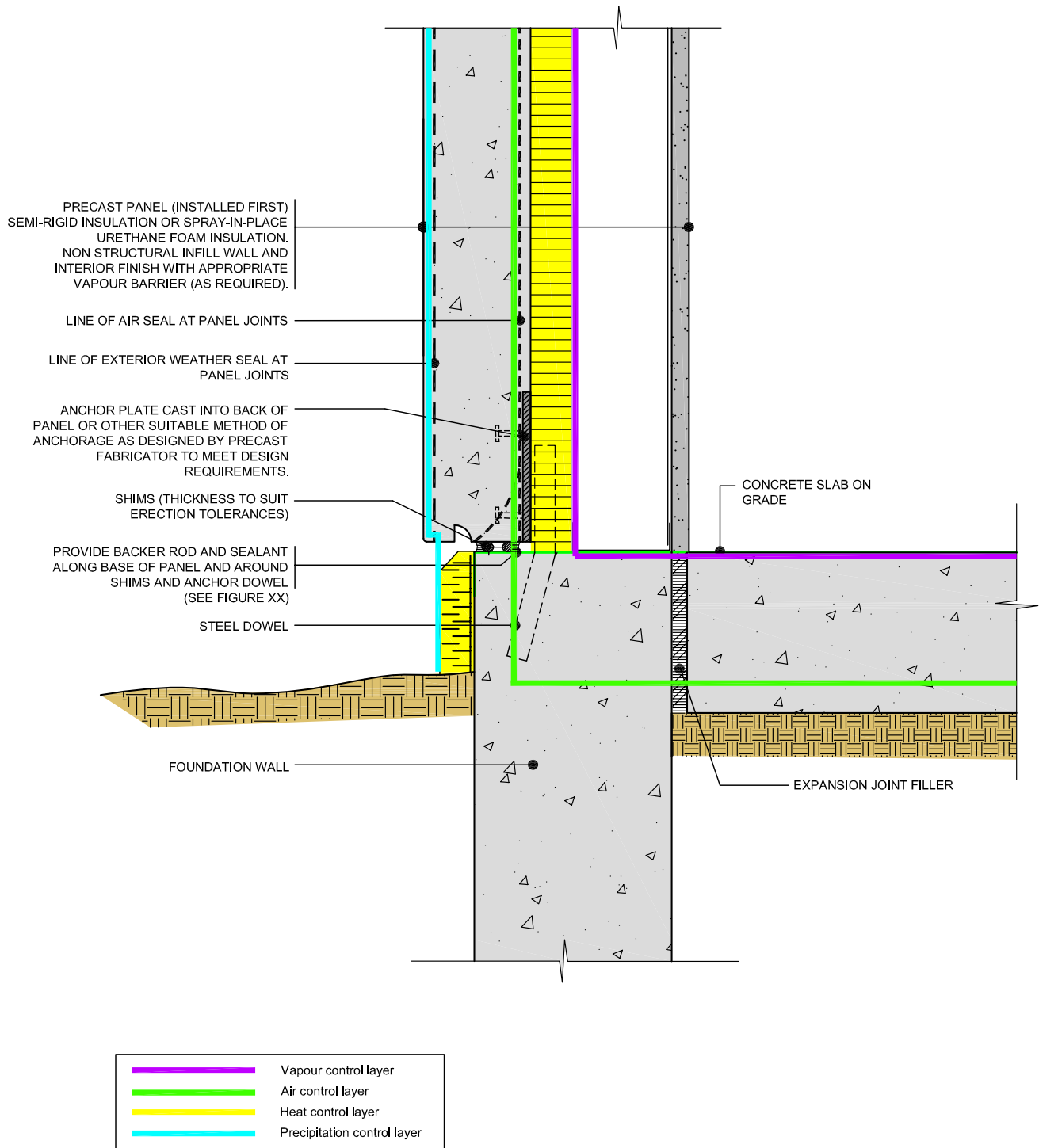

Detail drawing 5-1: Single wythe precast panel—bottom bearing and lateral foundation wall connection. Source: M. E. Hachborn Engineering

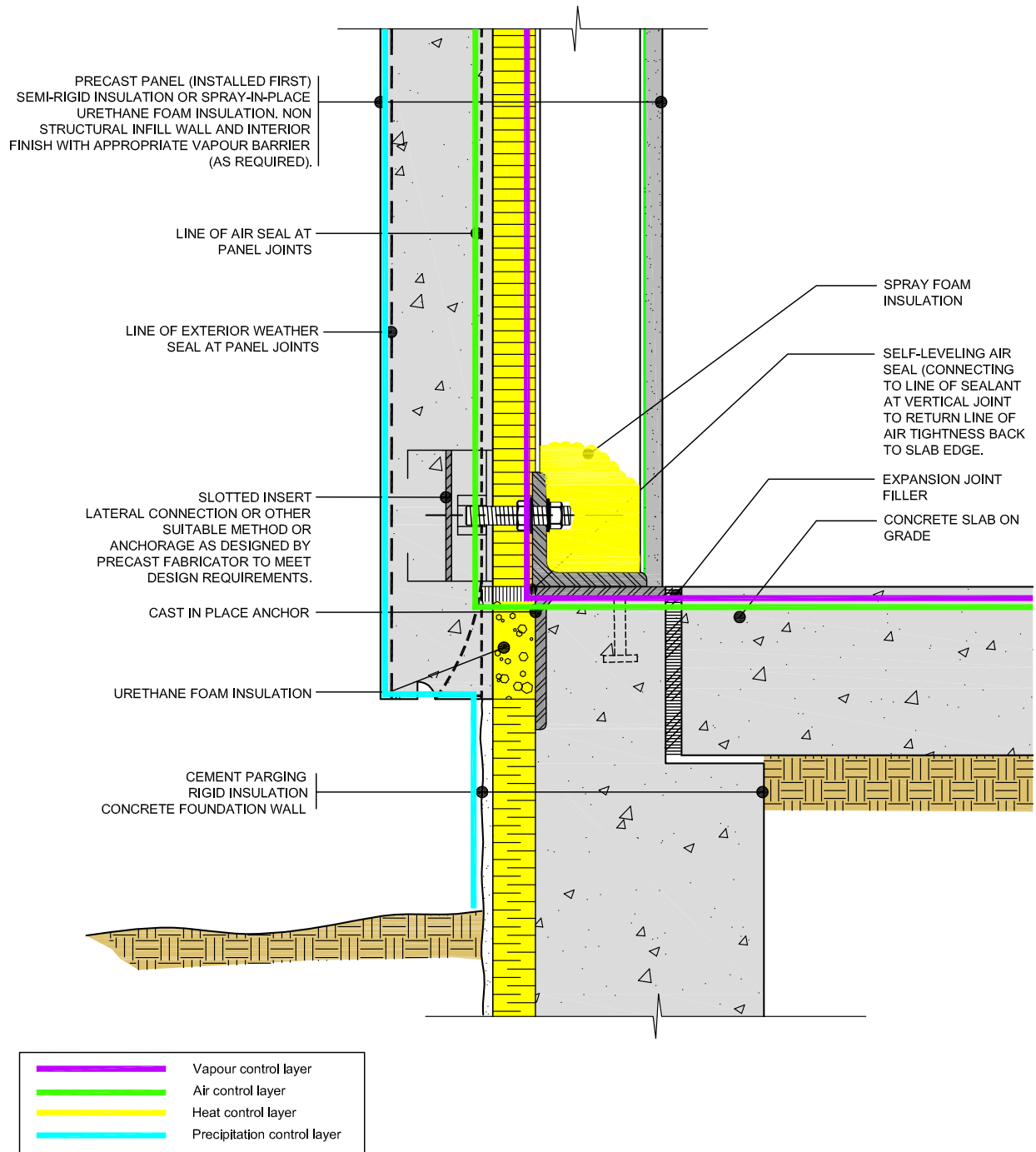

Detail drawing 5-2: Single wythe precast panel—lateral foundation wall connection.
Source: M. E. Hachborn Engineering

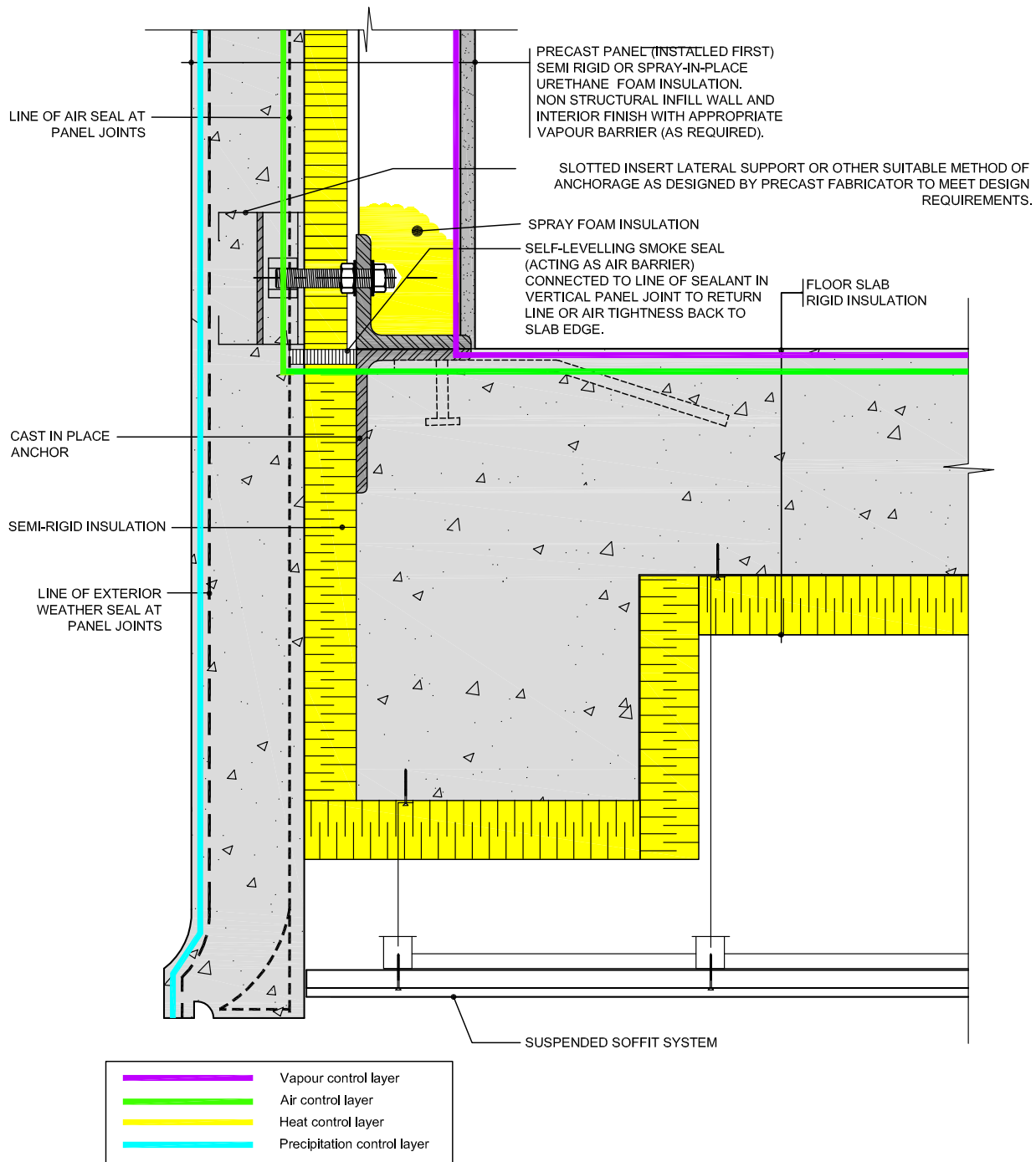

Detail drawing 5-3: Single wythe precast panel—suspended soffit. Source: M. E. Hachborn Engineering

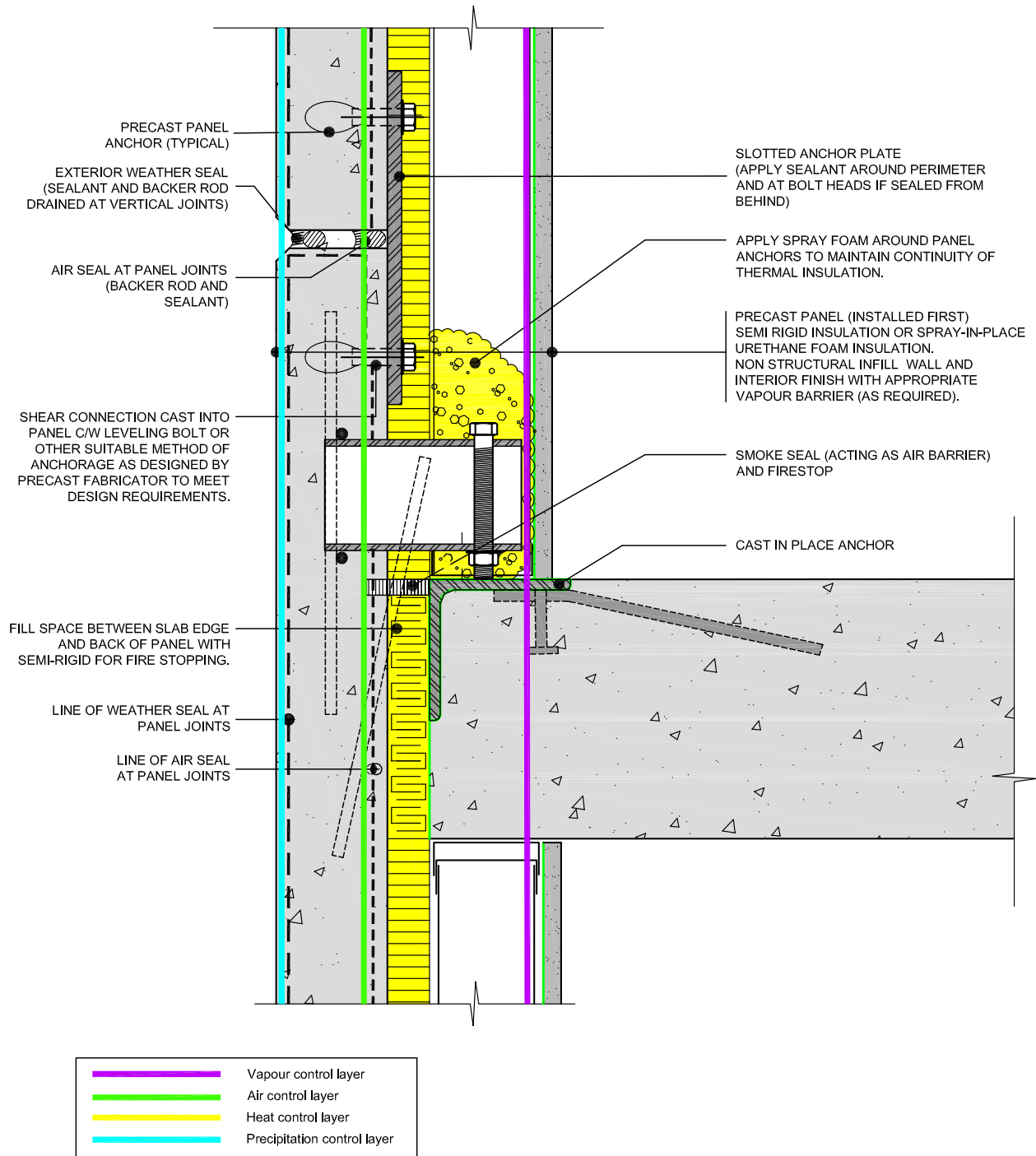

Detail drawing 5-4: Single wythe precast panel—slab bearing connection. Source: M. E. Hachborn Engineering

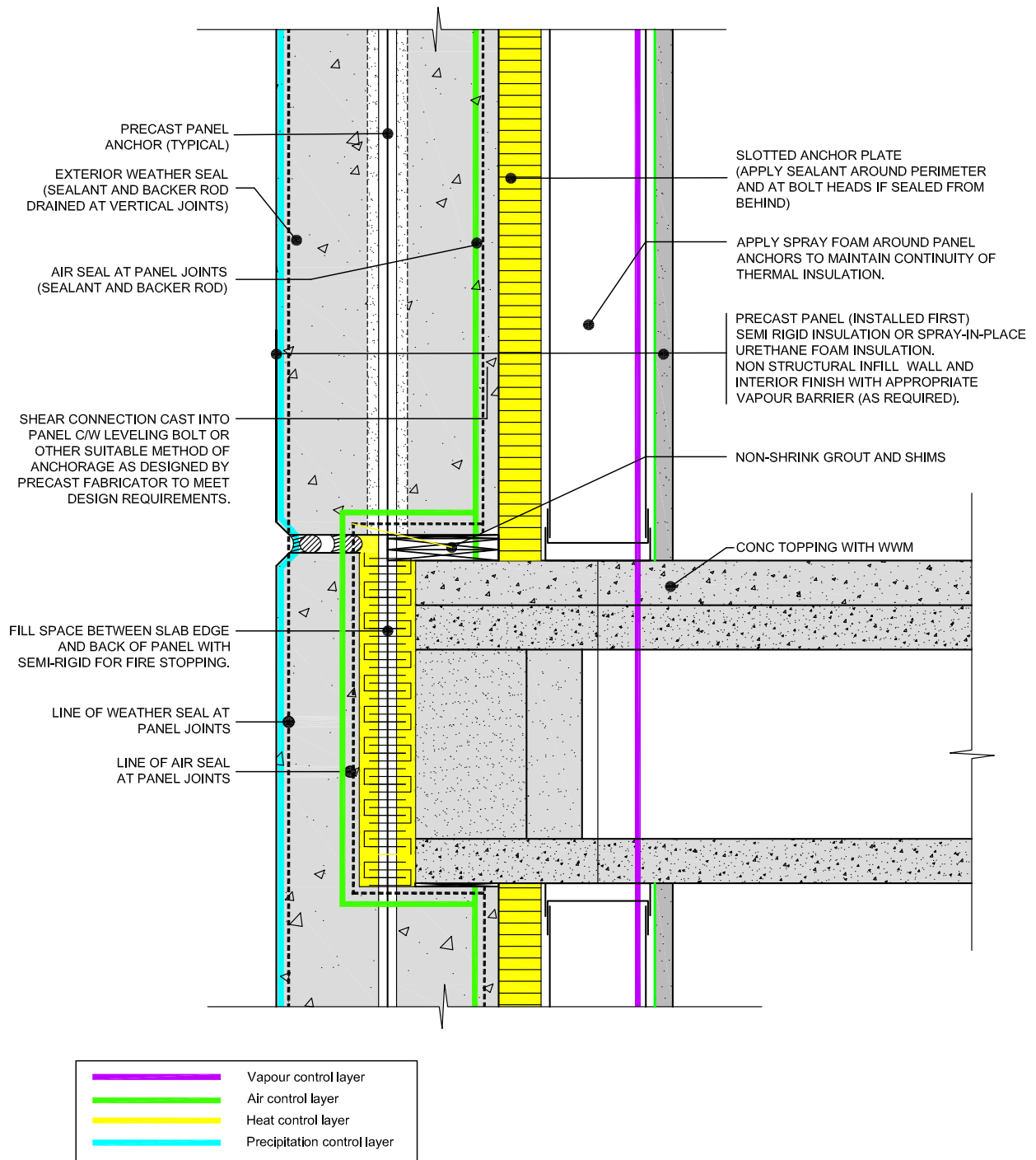

Detail drawing 5-4a: Single wythe precast panel—slab bearing connection total precast.
 Source: M. E. Hachborn Engineering

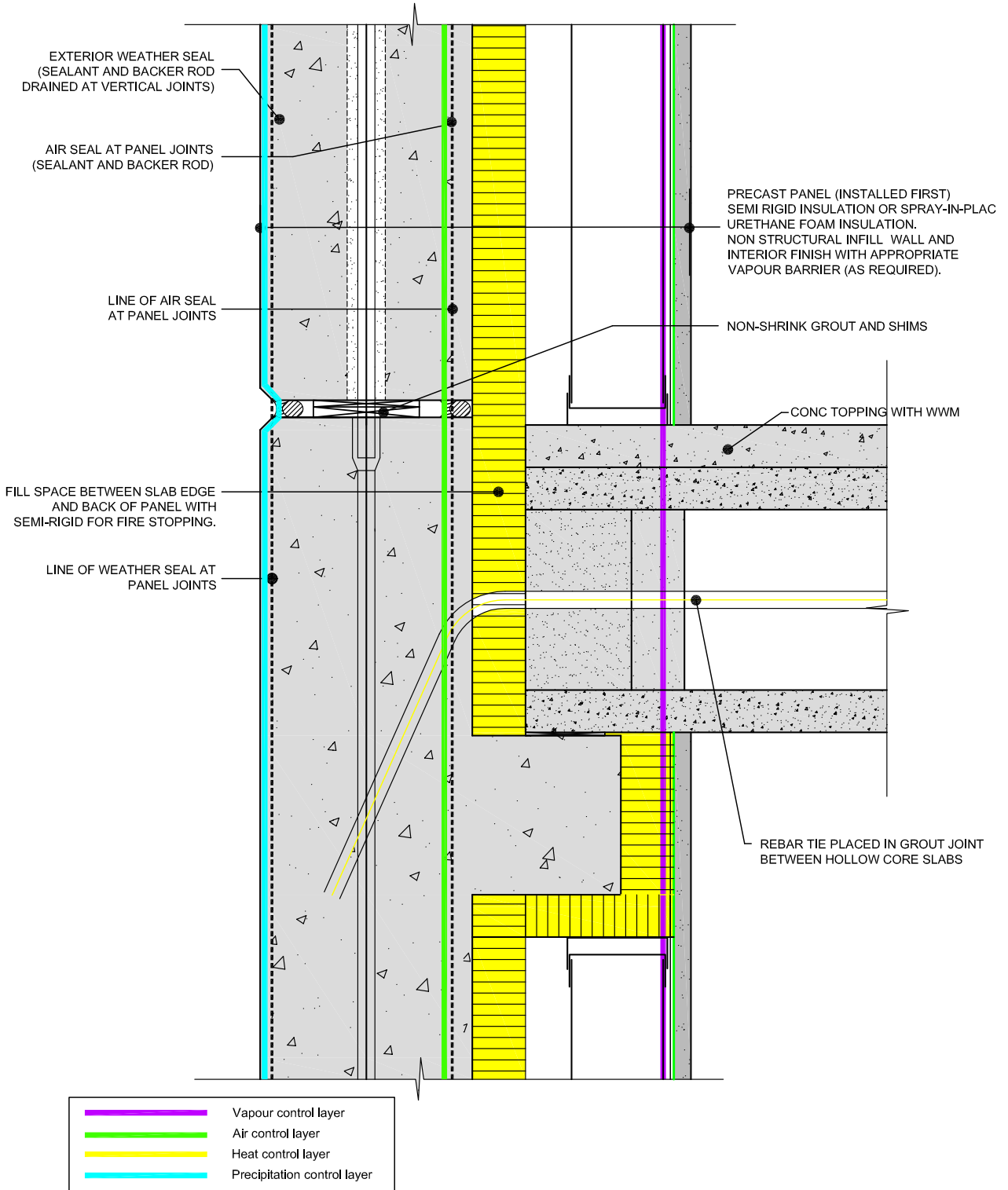

Detail drawing 5-4b: Single wythe precast panel—slab bearing connection total precast.
Source: M. E. Hachborn Engineering

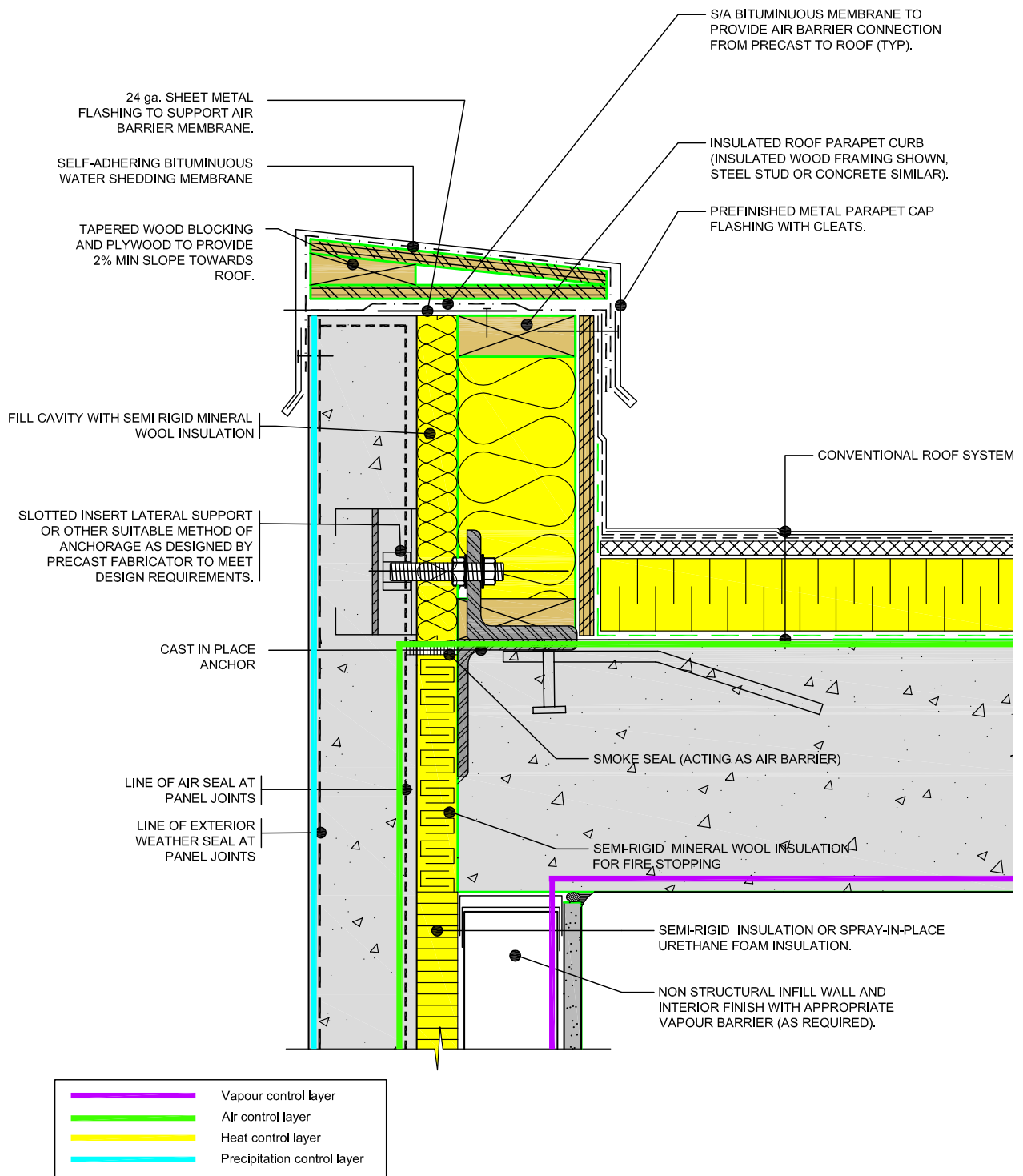

Detail drawing 5-5: Single wythe precast panel—lateral connection at parapet.
Source: M. E. Hachborn Engineering

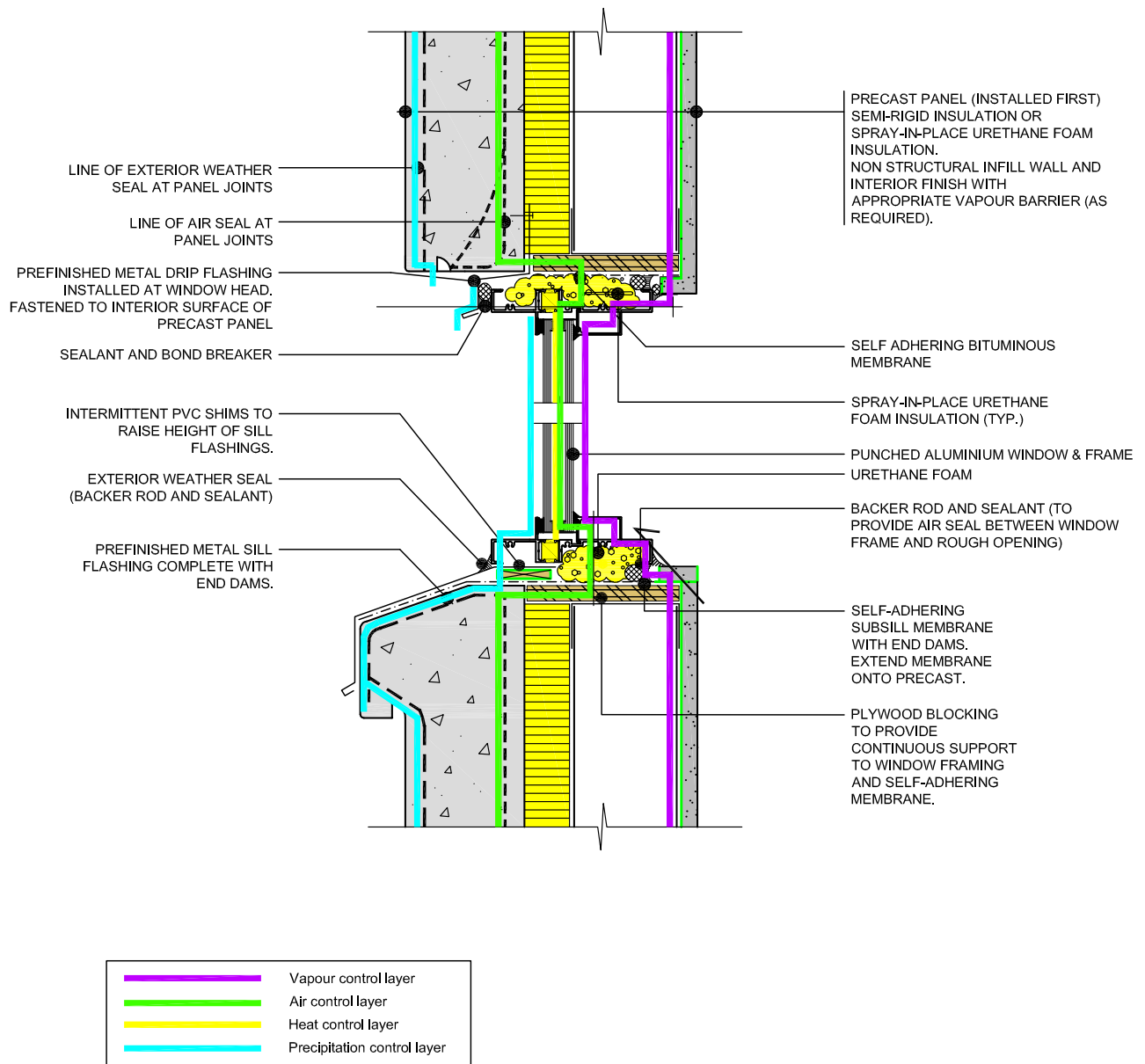

*Detail drawing 5-6: Single wythe precast panel—window head/sill connection.
Source: M. E. Hachborn Engineering*

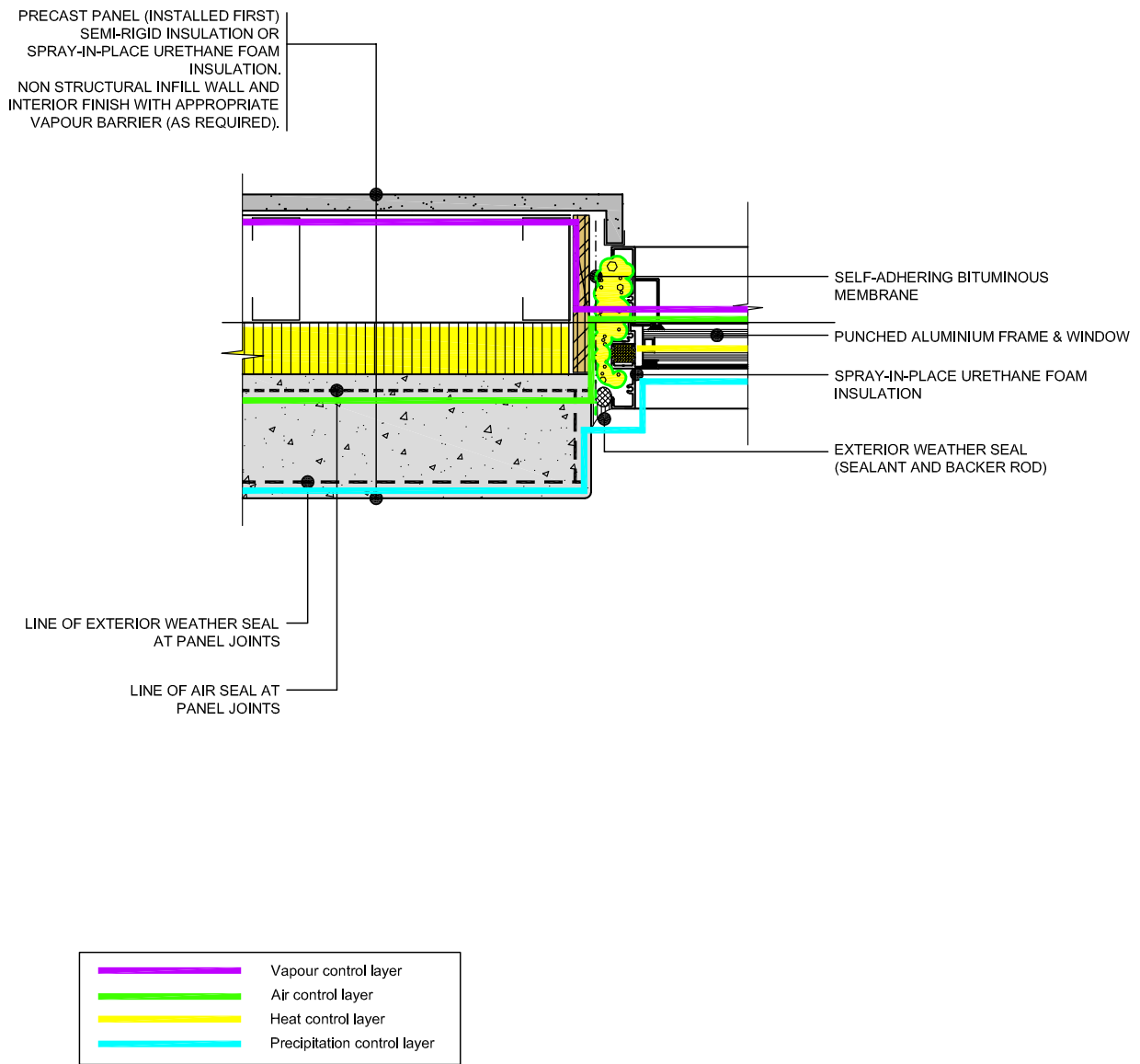

Detail drawing 5-7: Single wythe precast panel—window jamb connection.
Source: M. E. Hachborn Engineering

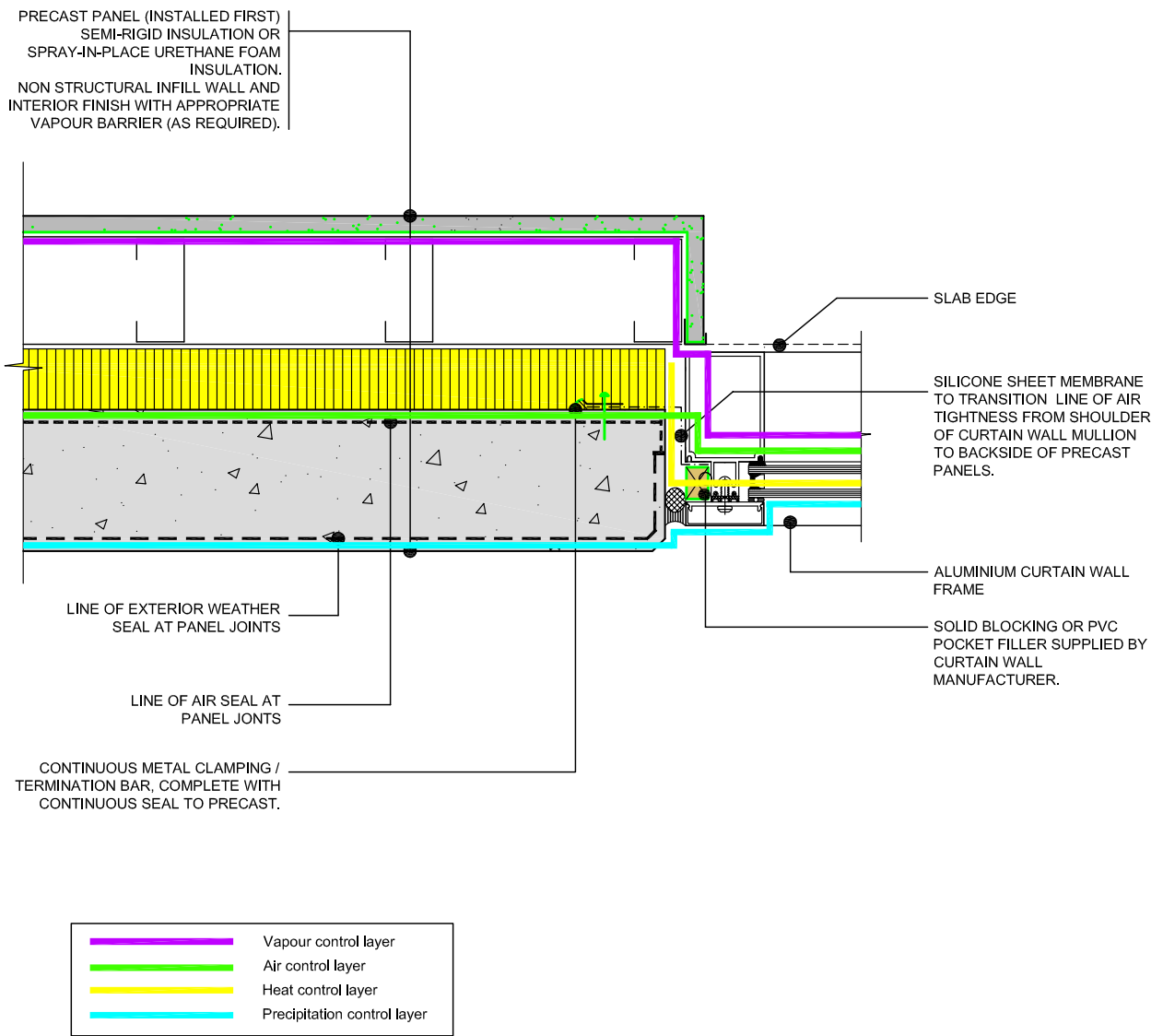

Detail drawing 5-8: Single wythe precast panel—connection to curtain wall jamb.

Source: M. E. Hachborn Engineering

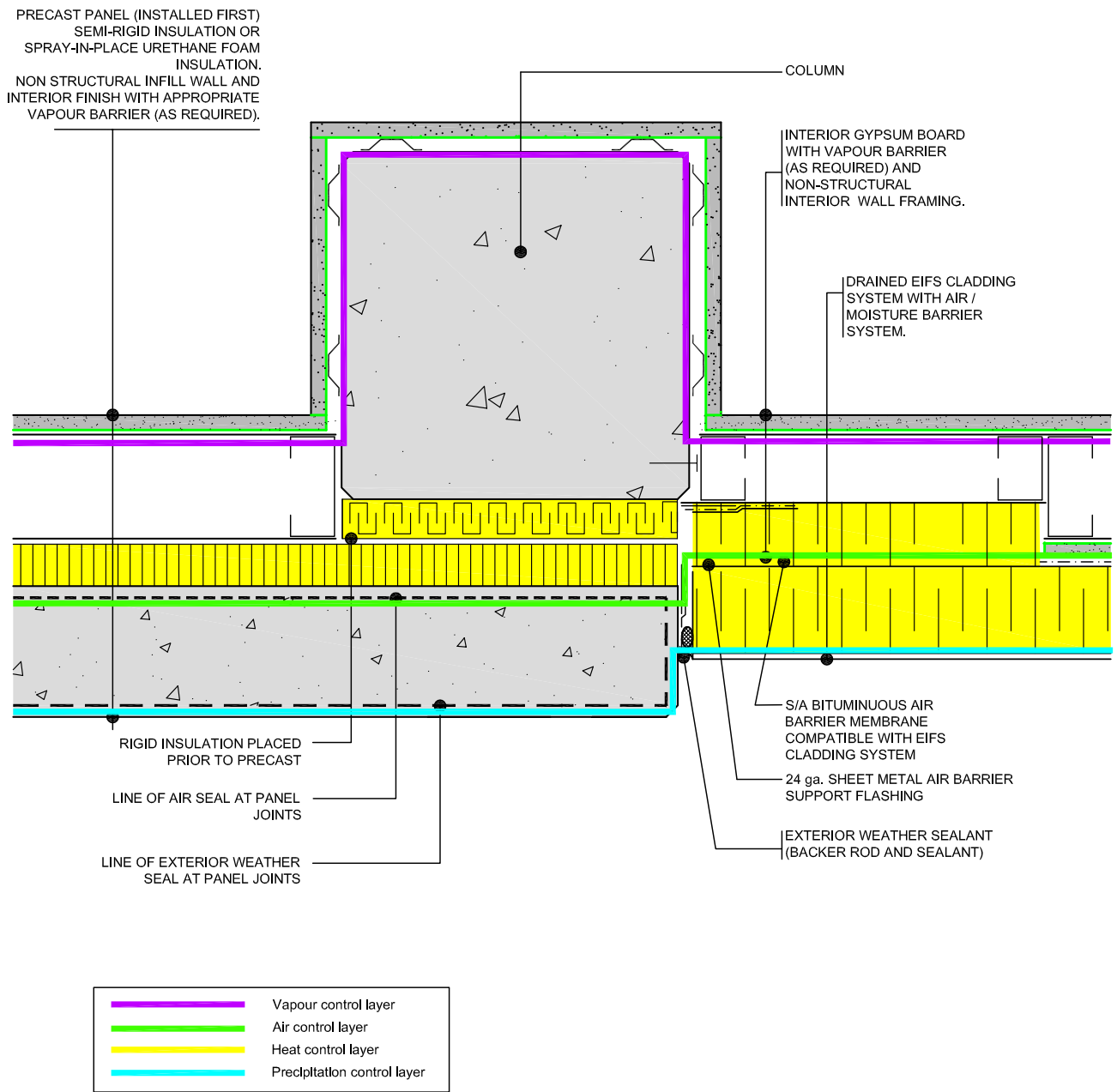

*Detail drawing 5-9: Single wythe precast panel—connection to EIFS cladding.
Source: M. E. Hachborn Engineering*

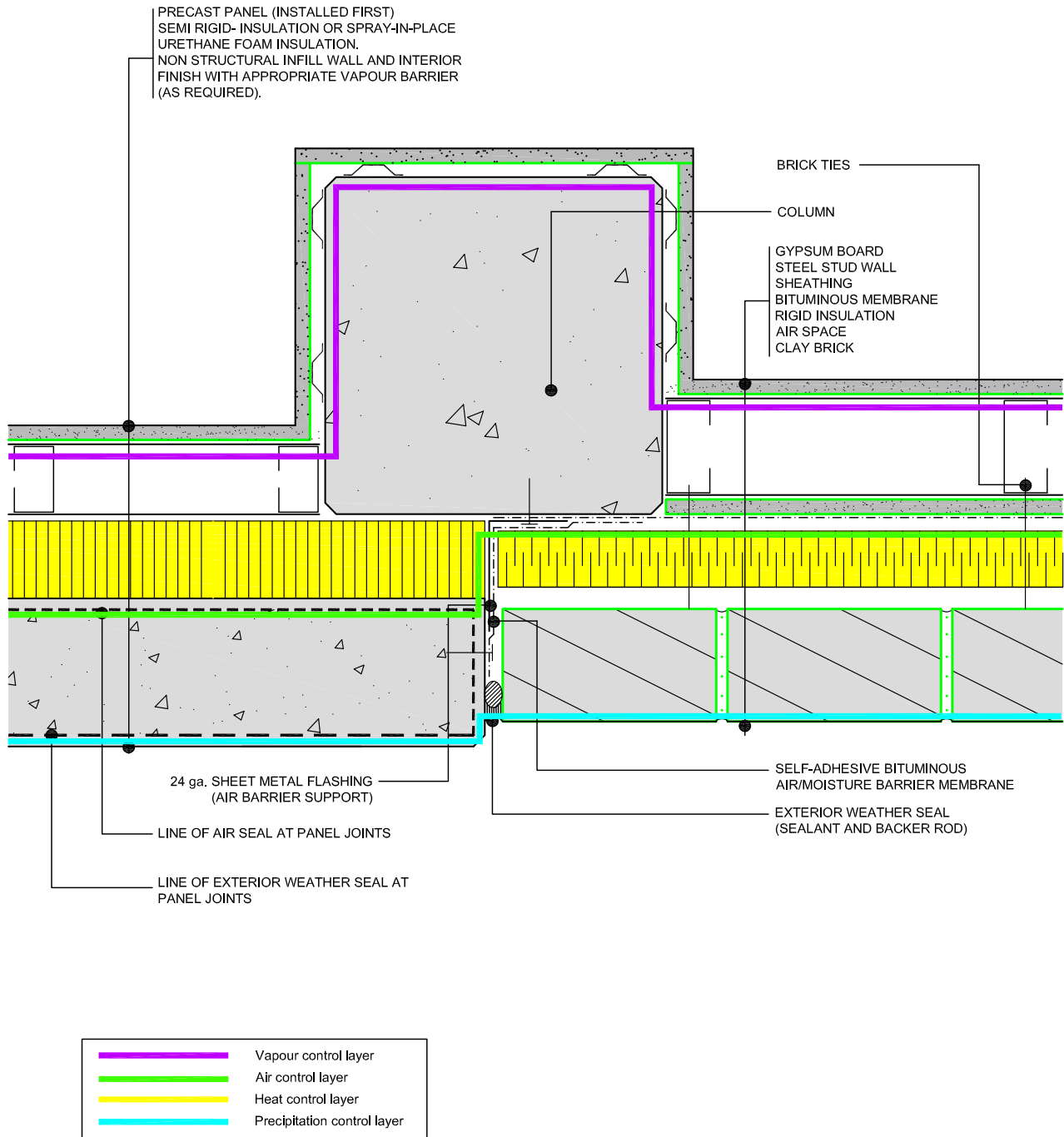

Detail drawing 5-10: Connection to precast panel—junction at brick veneer cladding.
Source: M. E. Hachborn Engineering

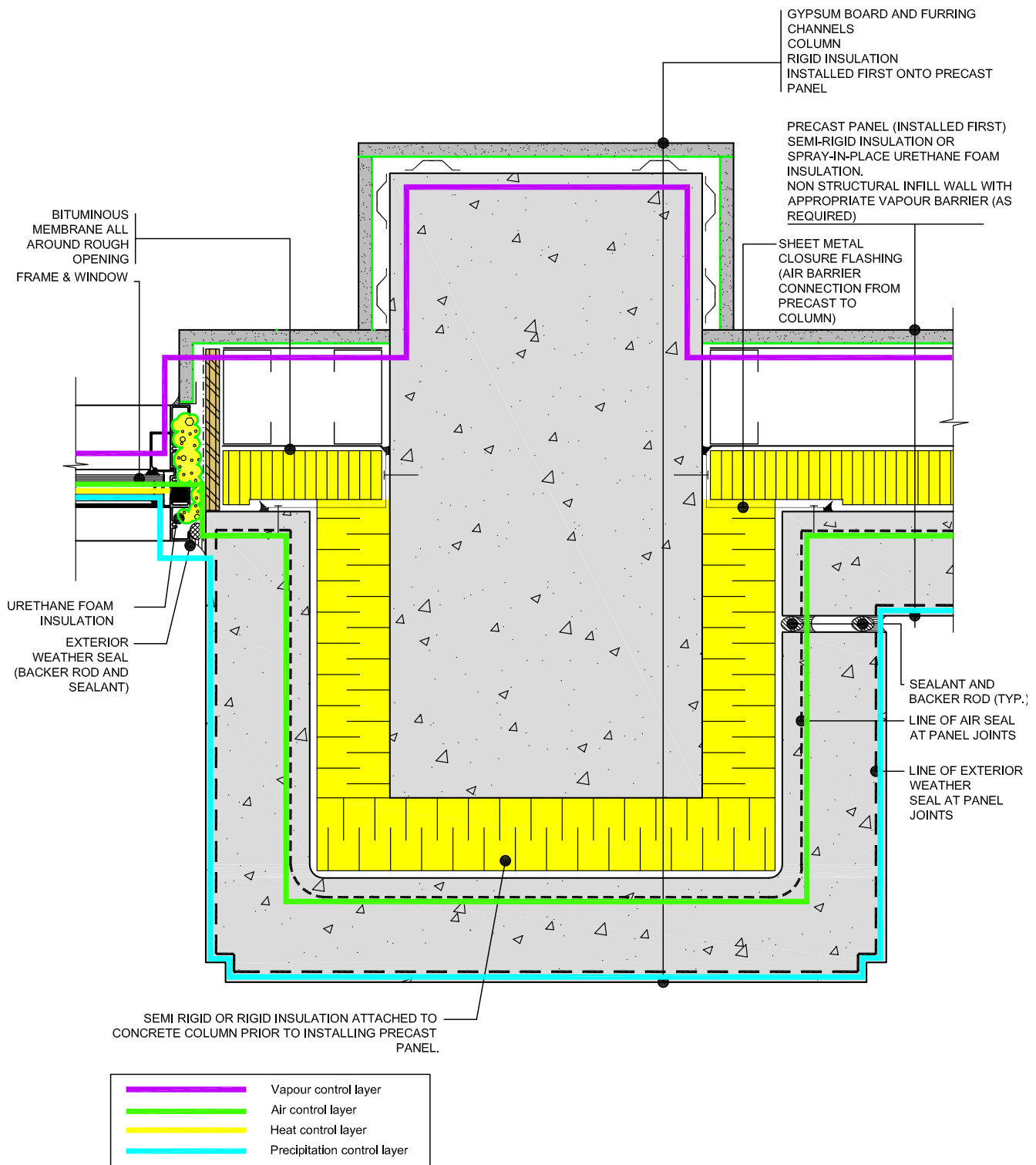

Detail drawing 5-11: Single wythe precast panel—projecting exterior column cover.
 Source: M. E. Hachborn Engineering

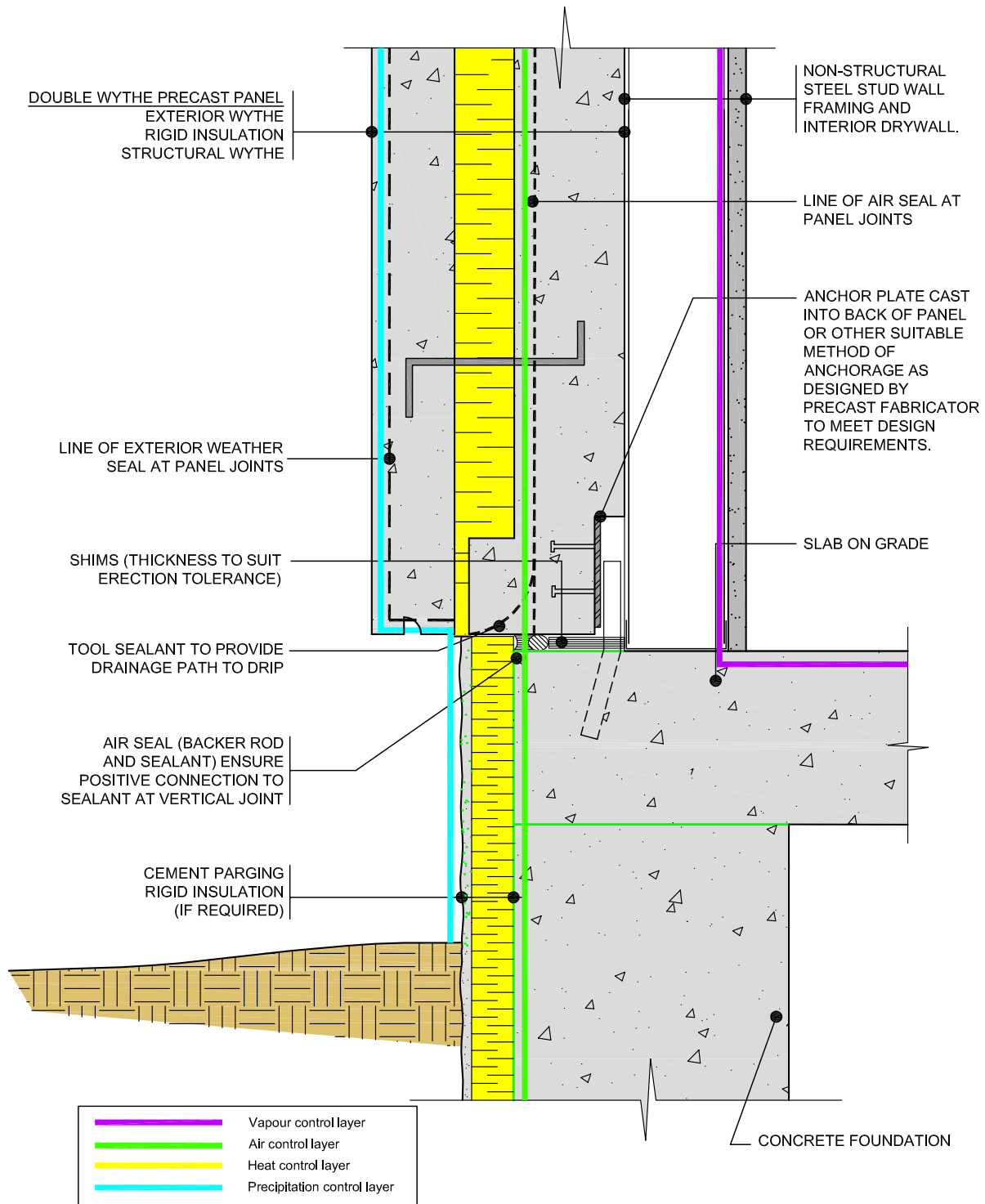

Detail drawing 5-12: Double wythe precast panel—bottom bearing foundation wall connection.
Source: M. E. Hachborn Engineering

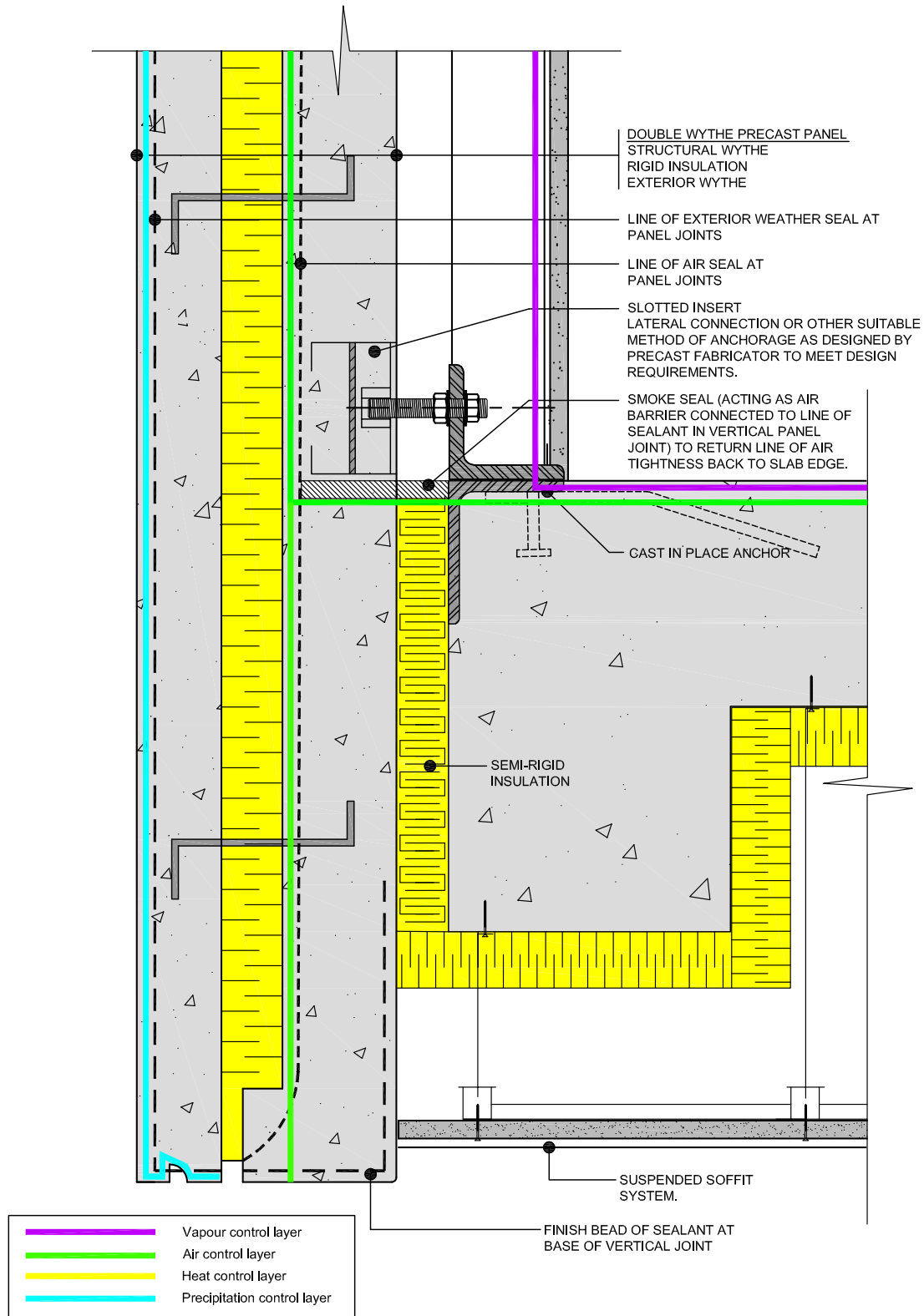

Detail drawing 5-13: Double wythe precast panel—suspended soffit and lateral connection.
Source: M. E. Hachborn Engineering

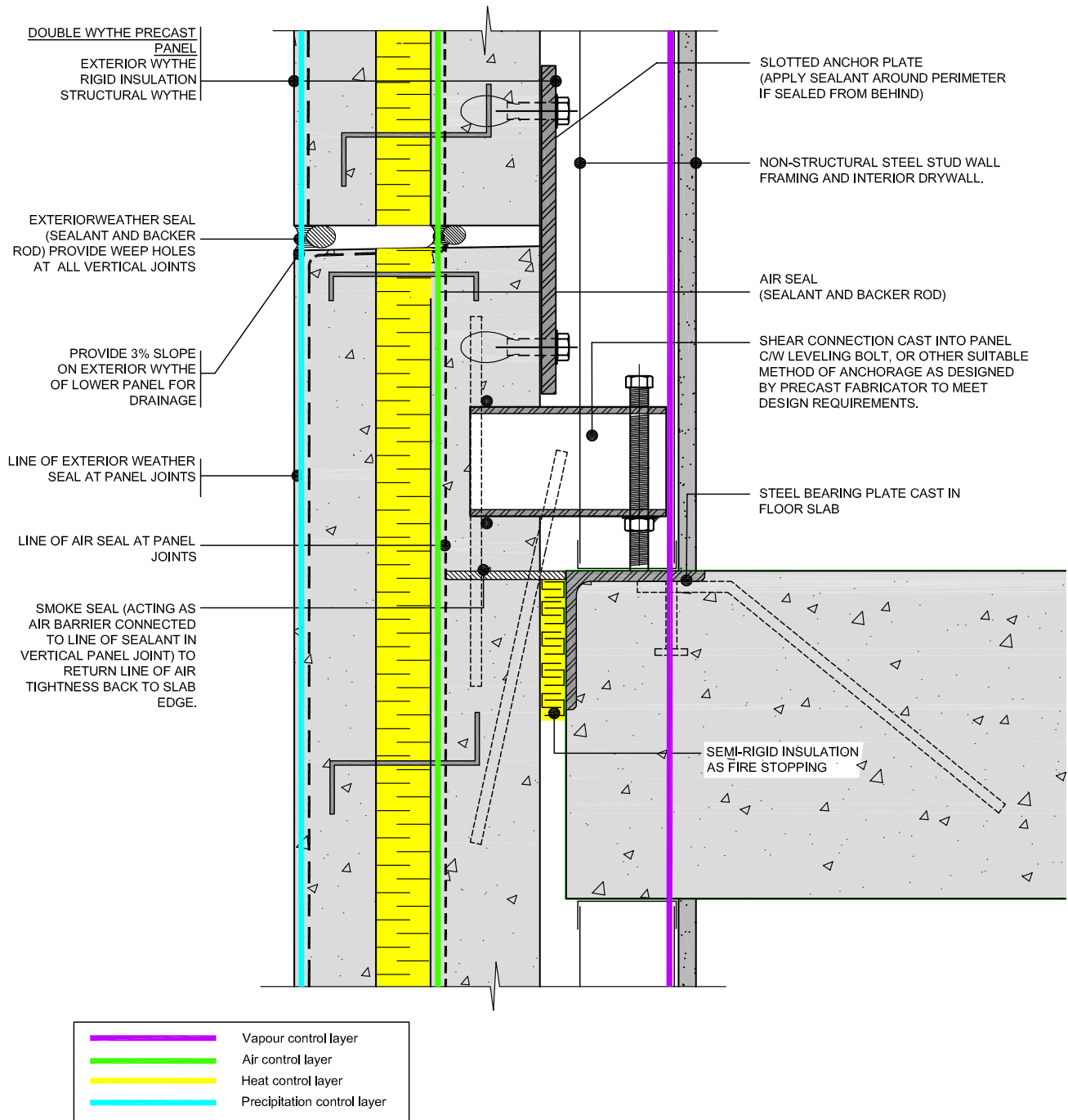

Detail drawing 5-14: Double wythe precast panel—bearing connection to slab edge.
Source: M. E. Hachborn Engineering

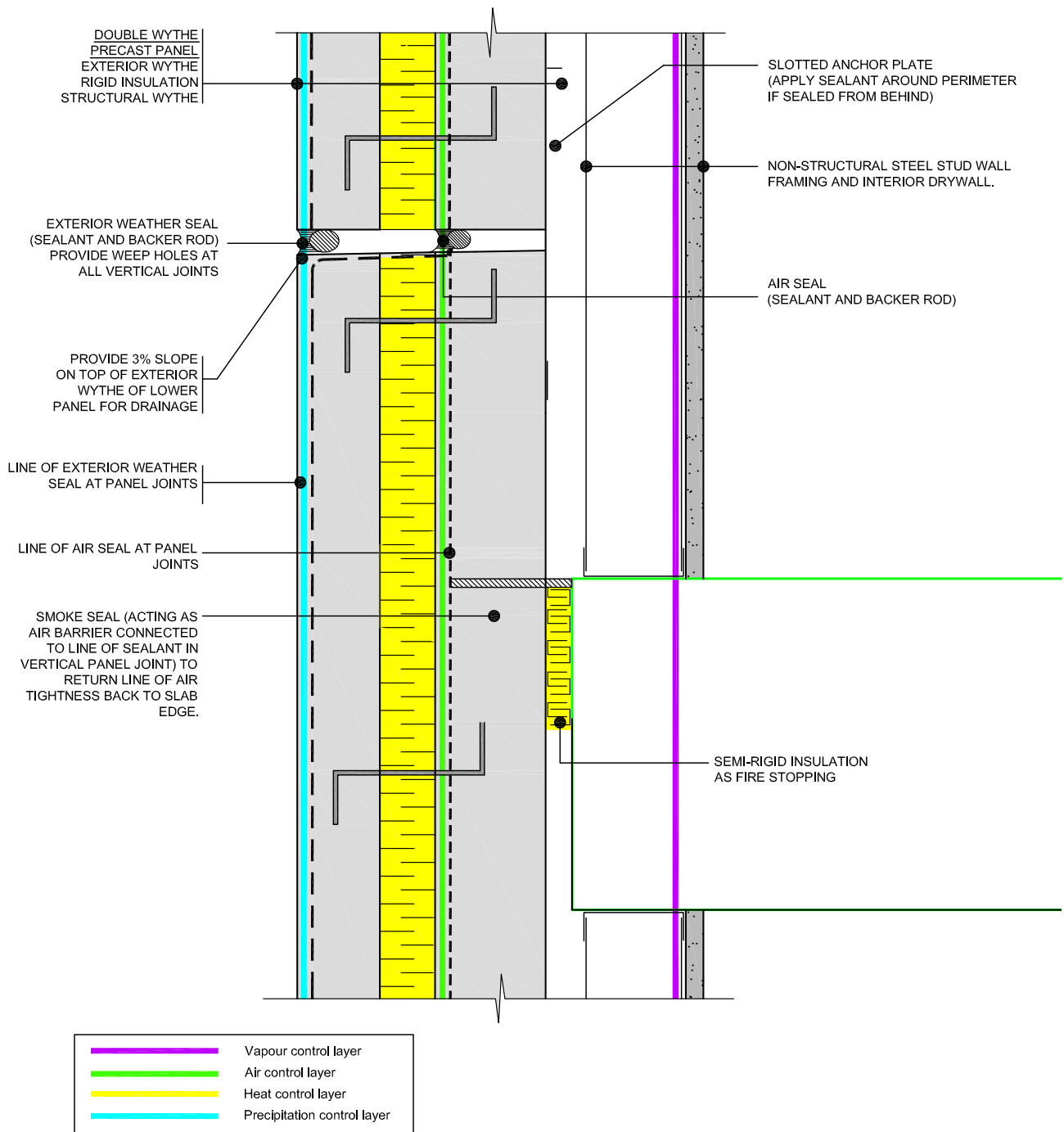

Detail drawing 5-14a: Double wythe precast panel—bearing connection total precast.
Source: M. E. Hachborn Engineering

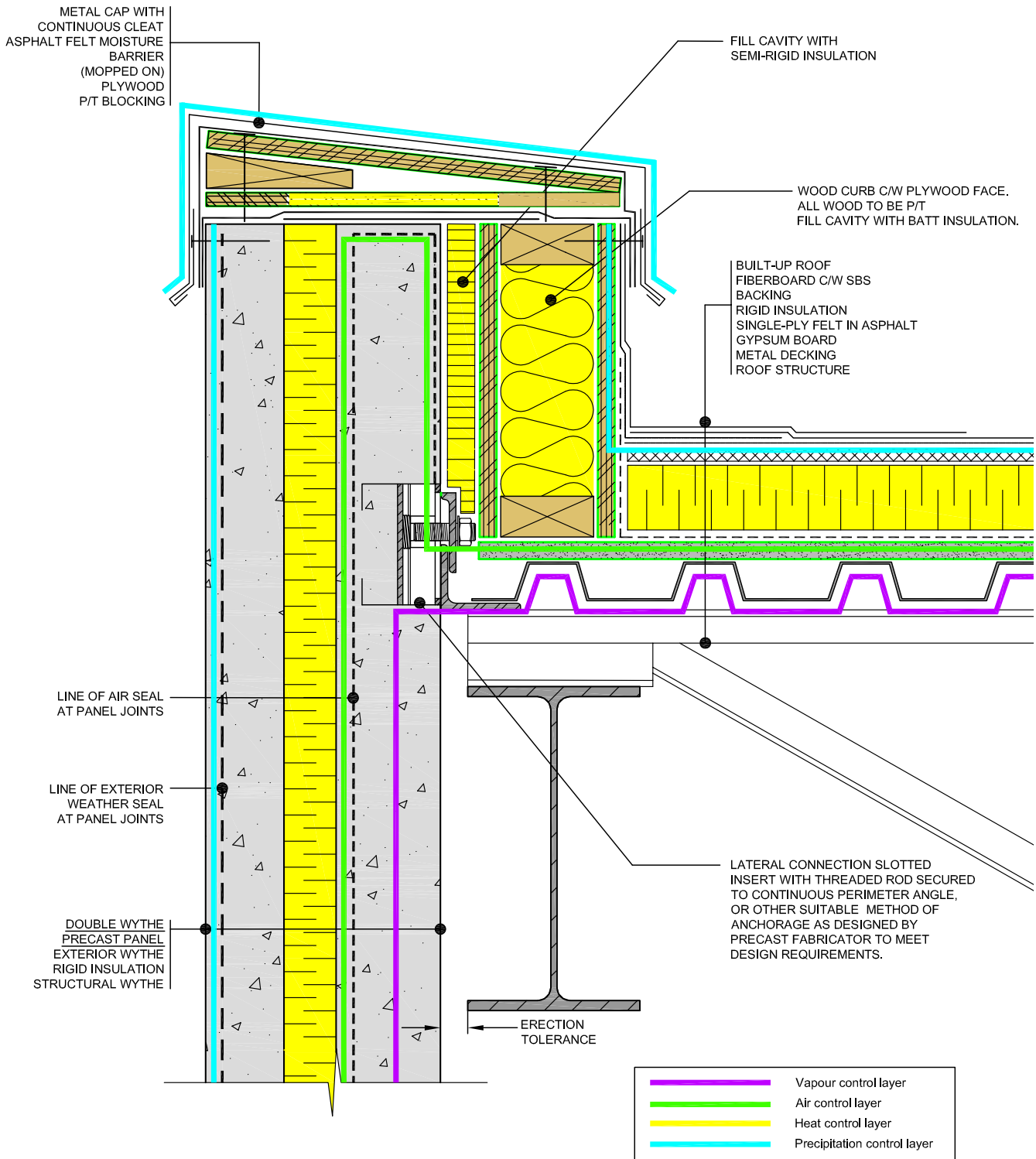

Detail drawing 5-15: Double wythe precast panel—lateral connection at parapet.
 Source: M. E. Hachborn Engineering

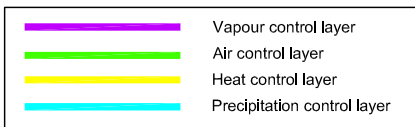
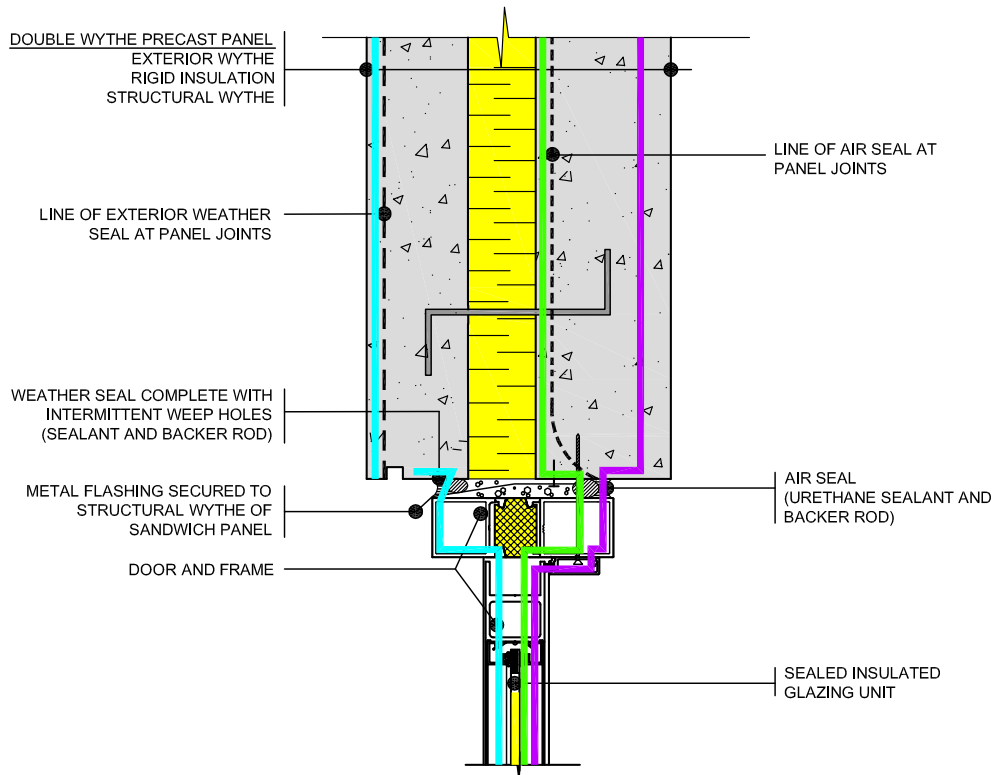

Detail drawing 5-16: Double wythe precast panel—connection to door head.
 Source: M. E. Hachborn Engineering

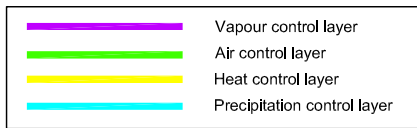
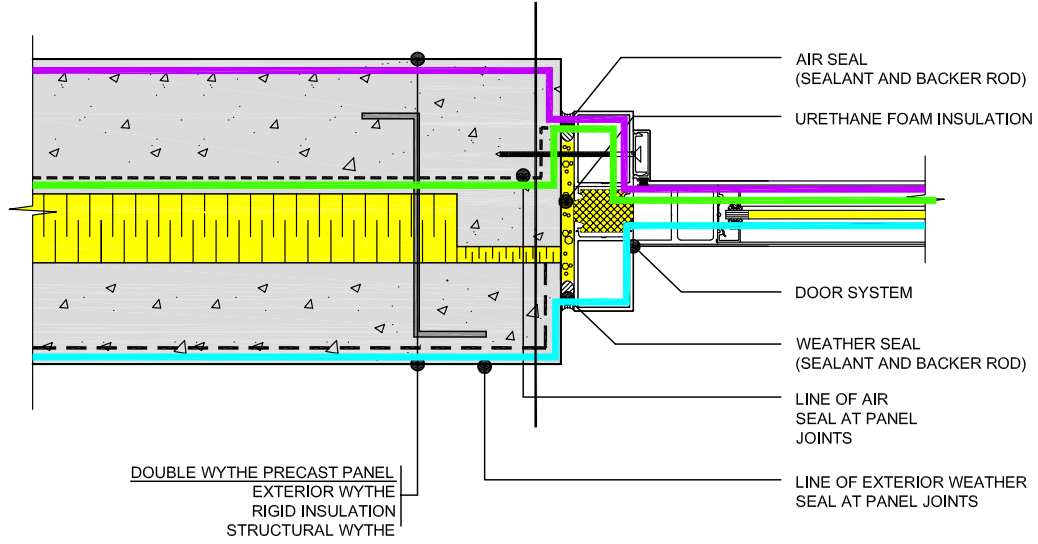

*Detail drawing 5-17: Double wythe precast panel—connection to door jamb.
Source: M. E. Hachborn Engineering*

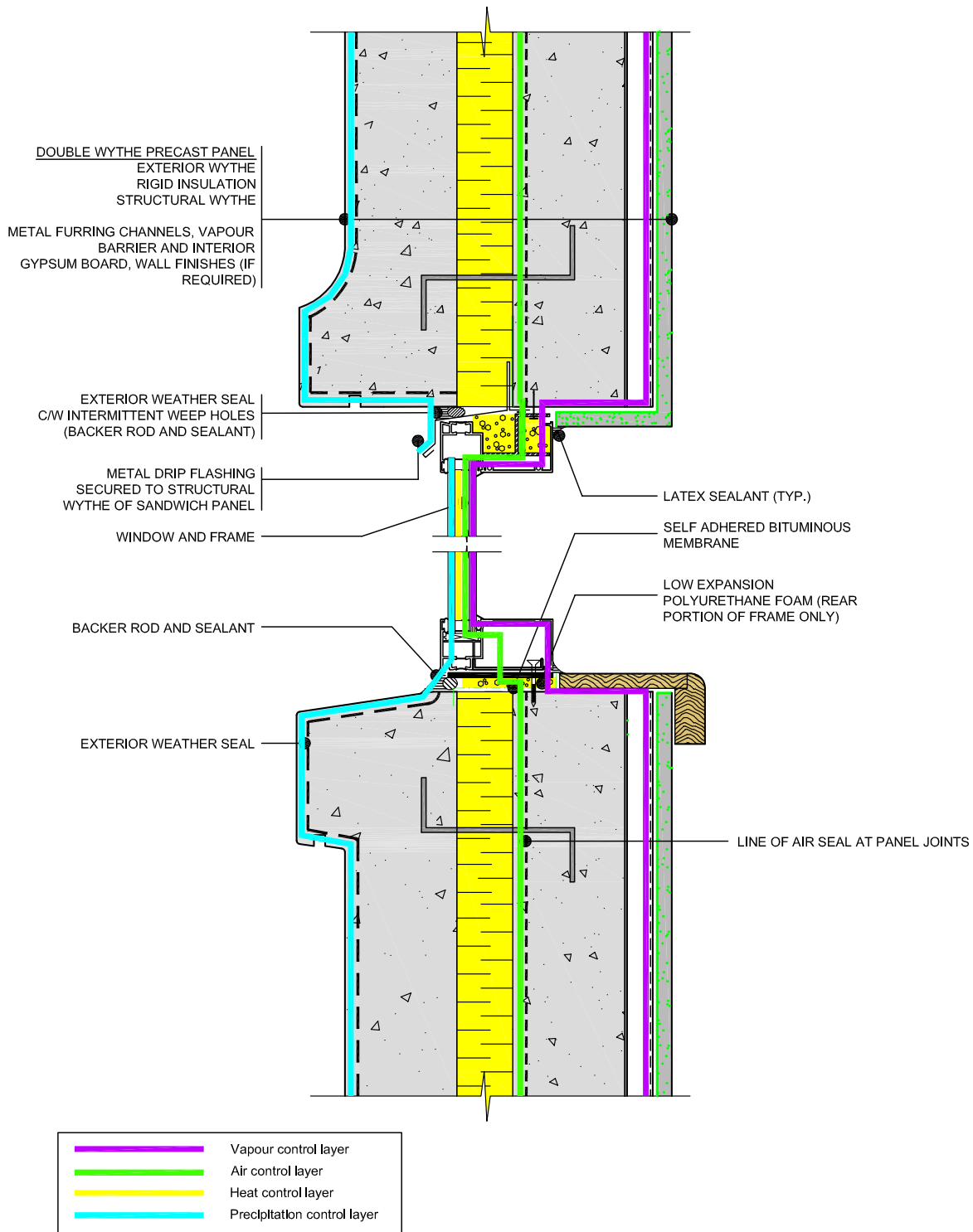

Detail drawing 5-18: Double wythe precast panel—window head/sill connection.
Source: M. E. Hachborn Engineering

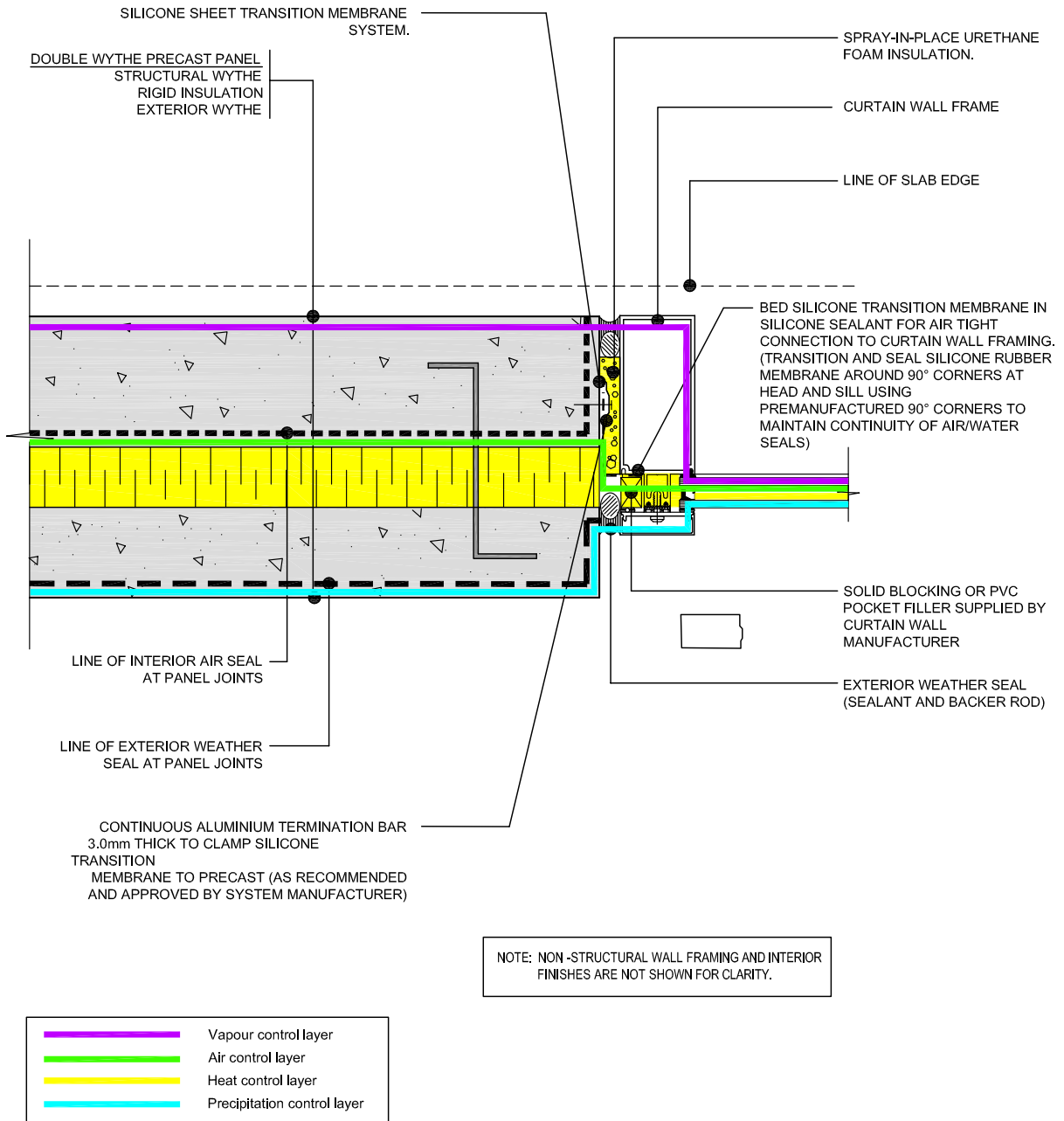

Detail drawing 5-19: Double wythe precast panel—connection to curtain wall.
Source: M. E. Hachborn Engineering

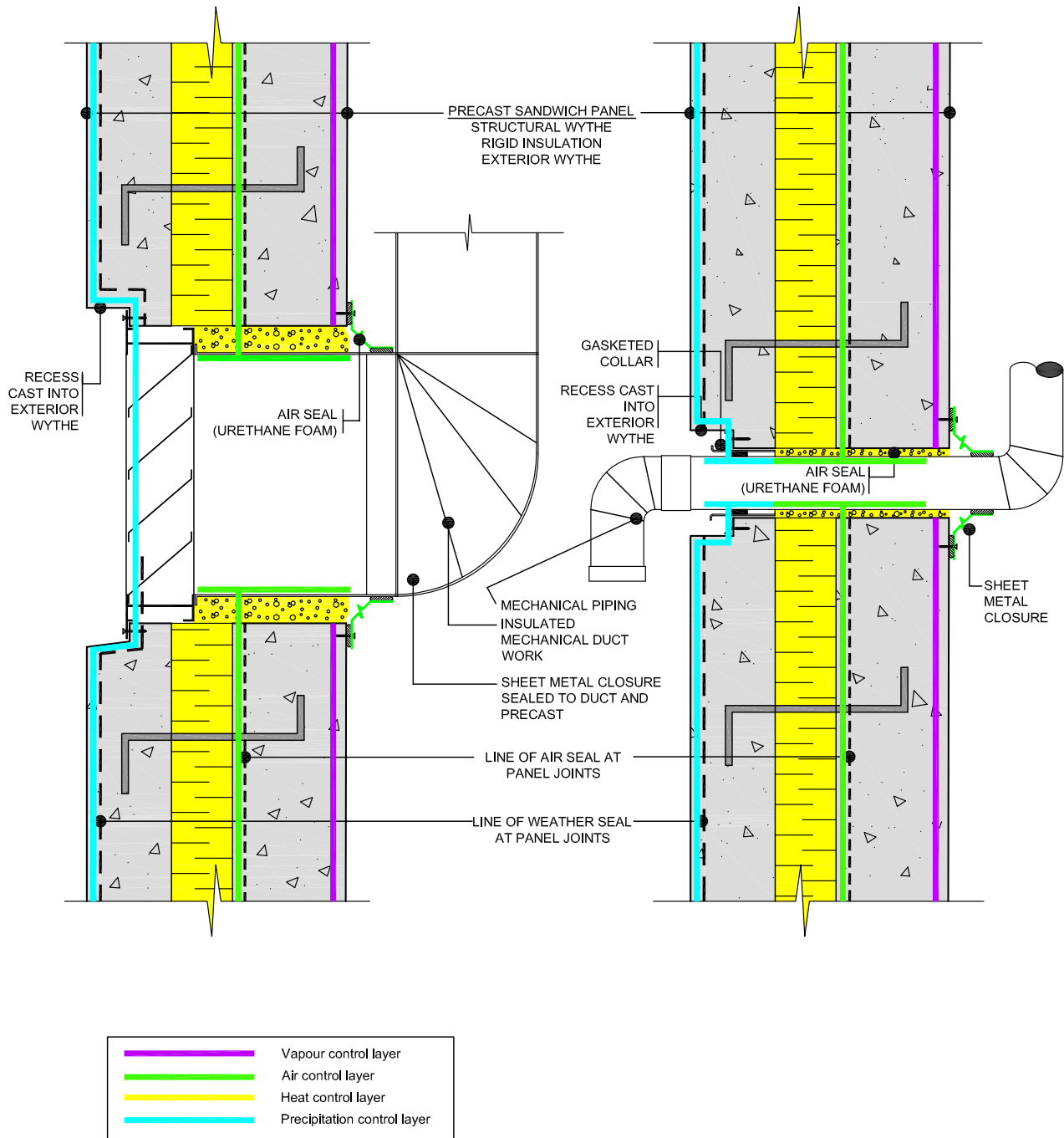

Detail drawing 5-20: Double wythe precast panel—service penetrations.
Source: M. E. Hachborn Engineering

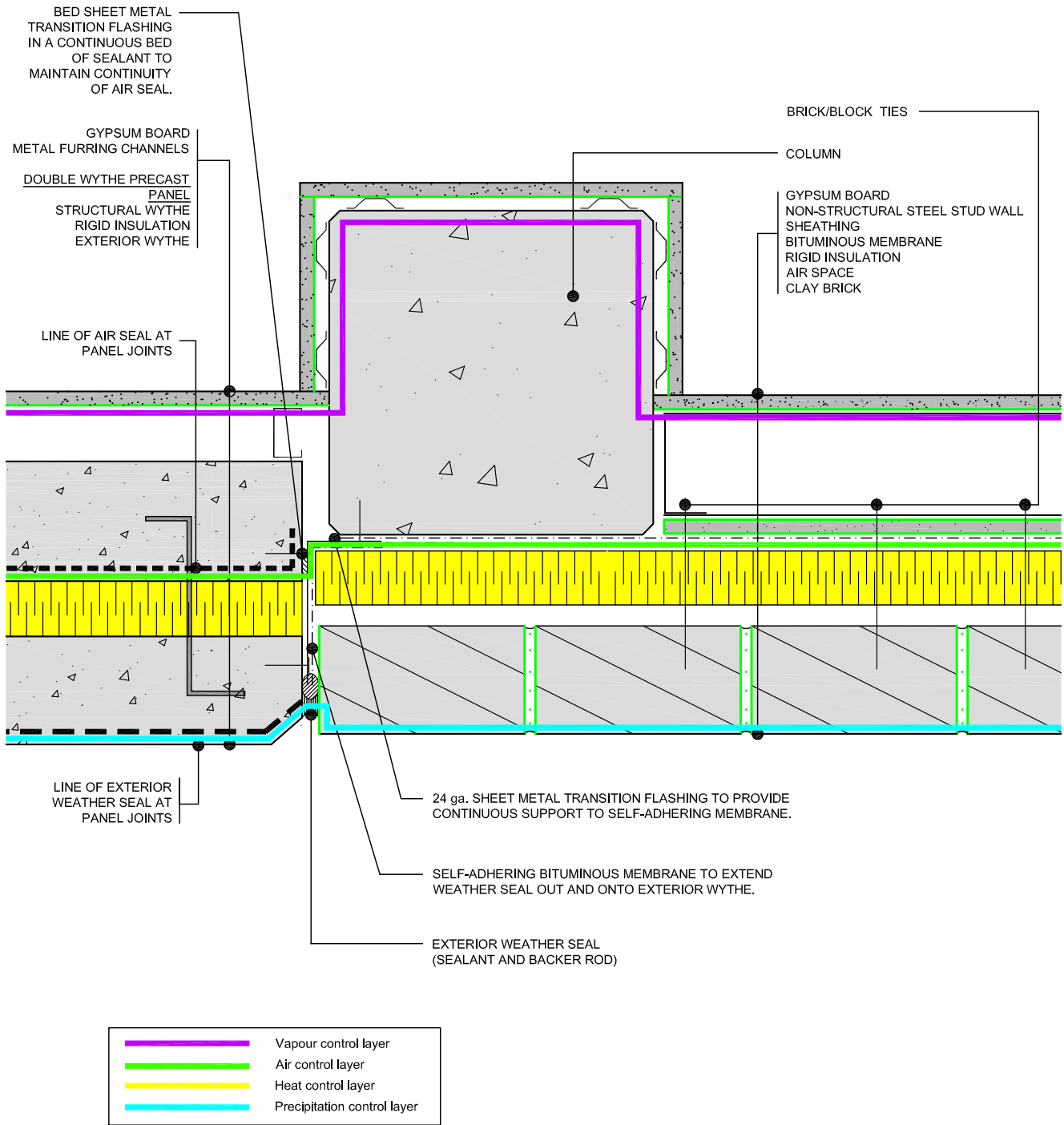

Detail drawing 5-21: Double wythe precast panel—connection to brick veneer cladding.
Source: M. E. Hachborn Engineering

CHAPTER 6 The Design, Tender & Construction Process

6.1 Quality Assurance and the Design and Construction Process

Quality assurance (QA), in the context of the building envelope, is defined as the process used to ensure that the constructed building envelope meets all of the performance requirements. The process includes quality control measures at the precast fabrication facility as well as systematic application of fundamental project quality control initiatives by all parties (including the owner, design team and general and trade contractors).

Quality control measures include the provision of construction review to determine general compliance to the design and contract documents, and material specific testing or sampling to confirm compliance to performance requirements of the design. Proper coordination of trades, sequencing of work, review of shop drawings, and effective communication between parties are examples of fundamental quality control initiatives that are required to ensure the overall success of the project.

Materials to be used and methods to be followed for the manufacture, transport and erection of architectural, plant manufactured, precast concrete is governed by CSA standard A23.4, Precast Concrete – Materials and construction (CSA, 2016). This standard specifies construction tolerances for wall panels (including main panel dimensions and joints between panels), procedures for fabrication and placement of reinforcement and hardware, concrete cover to reinforcement, concrete quality and procedures for concrete placement, curing and finishing. The designer and specifier should become familiar with this standard, especially with regards to items that directly impact the design, such as manufacturing tolerances.

Certification of architectural and structural precast concrete is a legal requirement of the National Building Code of Canada and the provincial building codes by reference to CSA Standard A23.3, Design of Concrete Structures (CSA, 2004) and to CSA Standard A23.4, Precast Concrete–Materials and construction (CSA, 2014).

CSA Standard A23.3, Clause 16.2.1 states (CSA, 2014):

*“All precast elements within the scope of this standard **shall** be manufactured and erected in accordance with the requirements of CSA Standard A23.4”.*

CSA Standard A23.4-16, Clause 4.2 Certification requires:

Precast concrete elements produced and installed in accordance with this Standard shall be produced by prequalified manufacturers.

Notes:

- 1) Annex A provides guidance on the requirements for a prequalification program.
- 2) Users may request that conformity assessment of precast concrete products or elements to this Standard be performed by an organization accredited to do so.

It is recommended that only precasters who are certified according to the CPCI Precast Concrete Certification Program be allowed to bid. Any issues arising from CPCI certified producers may be brought to the independent and third party Quality Assurance Council (QAC) for resolution. Other programs have no such resolution process.

The CPCI certification program is committed to delivering safe and cost-effective building and infrastructure products to support Canada's growing infrastructure demands. If you are an owner or specifier and have a concern about the quality of the precast from a CPCI certified plant, you can download the Quality Concern Reporting Form at http://www.precastcertification.ca/en/certification_program/#p1 and return the completed form to qacadministrator@precastcertification.ca. All concerns are kept confidential with the CPCI Quality Assurance Council (QAC).

The following are quality assurance activities that should be undertaken for all projects with architectural precast concrete wall panels:

- Architect should review client's output specification
- Independent consultant should review architectural specification to ensure compliance with the client's output specification
- Development of a precast concrete panel specification; see section 6.3 below for general specification requirements
- Precast panel shop drawing review by the project architect of record and by an independent building envelope consultant to ensure compliance to the client's output specification (This is very important to ensure that all building envelope requirements have been met)
- Sample review by the owner and/or the project architect
- Mock-up review by the owner and/or the project architect and the building envelope consultant
- Periodic plant review of panel manufacture by architect or building envelope consultant
- Periodic field review and final construction review by the precast engineer to ensure connections are completed as detailed and panel articulation will not adversely affect panel and sealant performance
- Periodic field review and final construction review by the owner and/or architect and the building envelope consultant
- Warranty review, prior to expiration of the warranty period, as required in the project contract

6.2 Detailing

Architectural detailing is an important task to be undertaken by the designer of record. Performance considerations need to be well understood and communicated to the contractor before implementation by the contractor. As with other building envelope systems, the successful performance of precast concrete assemblies relies on details that consider the following building science components described in detail in Chapter 4:

- Air barrier continuity
- Water penetration management
- Thermal insulation and minimizing thermal bridging
- Vapour diffusion control

The details need to accommodate structural movement, construction tolerances, and access for sealant installation. Refer to Chapter 5 for more information on panel edge design and joint design. Examples of key details that should be considered for every precast concrete design package include (as applicable to the project):

- Precast panel-to-precast panel joint design – both plan (vertical joints) and section details (horizontal joints)

- Base of wall detail at grade (joint of precast panels to foundation wall)
- Base of wall detail at roof (joint of precast panels to a roof assembly)
- Head of wall details at roof parapets (termination of precast panels at the top of a wall)
- Head, jamb and sill details at window openings (joints between precast panels and windows, all around windows)
- Head, jamb and sill details at curtain wall interfaces (joints between precast panels and curtain wall, all around curtain wall sections)
- Head and jamb details at door openings (joints between precast panels and door frames)
- Details at wall penetrations (for HVAC equipment openings, electrical openings, etc)

Other project-specific details may apply.

6.3 Specifications

A sample specification for architectural precast concrete panels can be found on the CPCI website (<http://www.cpci.ca/en/resources/specifications/>). The sample specification for architectural precast concrete wall panels is intended to be read in conjunction with the details provided in this best practice guide. Neither the details nor the specifications purport to illustrate the only design tools available for the construction of architectural precast. The architectural design team must interact with precasters during design development to review samples and select the form, texture and final finishes. Specifiers and designers should obtain information regarding local availability of materials and finishes, manufacturing methods and limitations, and historical evidence of satisfactory performance for specified materials.

The following paragraphs present information that precast concrete specifications should address, as well as issues which the specifier and designer should give particular attention:

1. Performance requirements, including, but not limited to, general conformance with the applicable building code, as well as structural requirements, thermal insulation, maximum air leakage rates, tolerances, deflection and clearance allowances, as applicable to the project,
2. Fabrication and erection to be conducted in conformance with relevant standards,
3. Certification of the precast manufacturer through the CPCI Precast Concrete Certification Program, and minimum experience requirements for both the precaster, the precast erector and the sealant applicator. Refer to the CPCI Architectural Precast Concrete Specification, <http://www.cpci.ca/en/resources/specifications/>,
4. Samples that illustrate surface finish, colour and texture, aggregates, pigments, finish depth, patterns, form liners, reveal profiles, joint treatment, for review and approval by the owner and/or design team. This includes range and repair samples,
5. Shop drawings by the precaster, with information on concrete to be used, associated materials (reinforcing steel and required corrosion protection, sealants, and other components under the responsibility of the precast contractor), connection details, and details showing not only embedments but may also include details at transitions with adjacent systems. Final shop drawings shall bear the stamp and signature of a professional engineer registered or licensed in the jurisdiction,
6. Inspection and testing of plant placed concrete and materials, in accordance with CSA A23.4. Optional testing may include, but is not limited to the following tests; tests to determine the suitability of colouring pigments, coarse and fine aggregate tests, structural testing of connection hardware, concrete slump, air void system, concrete compressive strength, and testing for facing materials such as brick, stone or other materials when used,

7. Field mock-up, of a given size and location, as selected by the consultant, including typical structural connections, finishes in accordance with approved samples, joint sealant installation and performance testing,
8. Delivery, storage and protection, in accordance with the manufacturer's requirements to avoid staining and damage to panels,
9. Materials, for concrete mixes; cement type, aggregates, reinforcement, chemical admixtures, pigments. The precast manufacturer is responsible for design of the concrete mix, which must be proportioned to meet the specified properties. The specified properties should meet the performance requirements of CSA-A23.1 and CSA-A23.4. A minimum mix design based on exposure classification F-2 (concrete in an unsaturated condition exposed to freezing and thawing) should be specified. This exposure classification is appropriate for exterior wall panels in areas not subjected to chlorides (deicing chemicals). A more severe exposure class may be warranted, for precast panels exposed to seawater spray, deicing salts at grade, or other corrosive environments (C-1). Manufacturing requirements, such as the need to often remove forms within 24 hours of casting, may govern the actual mix design, including the use of supplementary cementitious materials and high early strength cement,
10. Support devices and accessories. Zinc plating or hot dipped galvanizing of precast anchors, support and lifting hardware is recommended as the minimum required level of corrosion protection. Stainless steel hardware may also be used, but is only necessary in extreme cases. The preference is for bolted connections as opposed to field welding, which can negatively affect the corrosion protection of the support hardware, and may also make future removal and relocation or replacement more difficult if and when required,
11. Manufacturing capabilities of local precast facilities and historical evidence of long-term performance of the desired finish are important considerations for the designer. Available manufacturing expertise, techniques and practices should be discussed. Consultation with the manufacturing plants in the preliminary design stages is always recommended,
12. Fabrication requirements, including tolerances, and source quality control and testing, with reference to relevant standards (refer to relevant standards and CPCI's Architectural Precast Concrete Specification <http://www.cpci.ca/en/resources/specifications/>)
13. Execution, including; examination of existing conditions prior to panel installation, preparation of temporary bracing, and erection activities, including panel alignment, structural welding, touching up of damaged finishes and sealant installation,
14. Repair techniques in the plant and field, and
15. Cleaning, if required, of installed work, and provision of documentation relating to maintenance requirements. Refer to the guide document Maintenance and Inspection Manual for Precast Concrete Building Enclosures, by RDH Building Science Inc., relevant standards, and CPCI's Architectural Precast Concrete Specification, <http://www.cpci.ca/en/resources/specifications/>.

6.4 Tender

6.4.1 Samples

Each precaster intending to bid should be required to provide pre-bid colour and finish samples showing the panel colours and textures (sample size generally 300 mm x 300 mm). Technical descriptions of the concrete mix, aggregates and finishes should be provided and checked against the specifications. This prequalifies the precaster and allows competitive bids from firms with adequate capability.

6.4.2 Pre-Bid Conference

Complete contract drawings should be provided to the bidders prior to this conference. Incomplete drawings will lead to additional costs due to allowances being added for unknown conditions. Missing details may also lead to additional charges for extras once the project has been awarded due to misunderstood conditions, some of which may have already been allowed for with the above noted allowances. Approved precasters and the general contractors should meet with the design team prior to the award of the precast contract to clarify any unclear conditions or details, review material sources, production capability and schedules. Requirements for shop drawings, design submittals and mock-up panels should be reviewed, as per the contract documents.

6.4.3 Contract Award

Once the bids have been evaluated and the contract awarded, the contract requirements should be reviewed with the successful bidder immediately following award. If bids are found to be incomplete, the precaster should be disqualified and dismissed and the next bid reviewed. Under no circumstances should incomplete bids be accepted.

Shop Drawings

Prior to the commencement of precast shop drawing preparation, complete architectural and structural drawings are required. All details should be fully developed and included in the contract drawing set. Failure to provide these details at this time may lead to additional costs to the contract due to longer detailing duration and extras charged by the precast manufacturer and sub trades during construction.

Shop drawings are normally produced by the precast manufacturer. The necessity of accurate shop drawings, proper coordination by the general contractor and architect, and the thorough review of these drawings by the architect and all trades is paramount. Many issues need to be carefully considered and incorporated into the design prior to final approval for production. Examples include review of dimensions, location and tolerance for connections (for loading on the structure), interface tolerances, and connection interference with the structure and other elements such as windows and adjacent building envelope assemblies. The inclusion of mechanical openings, electrical openings and window attachment devices will save all parties time and money during precast erection and other component construction. Site lifting equipment capacities and access also need to be considered. Incomplete architectural drawings and frequent drawing changes will cause delays and increase the cost of the project.

Preparation of shop drawings stamped by a qualified professional engineer is the responsibility of the precast manufacturer. Requirements for the shop drawings are specified in CSA A23.3 and CSA A23.4. Shop drawings include general arrangement drawings, erection drawings, connection details, and cast in place and/or pre-weld hardware drawings showing the location of embedded or pre-welded hardware to the structure. Internal plant drawings for connection hardware and production drawings for the individual precast panel elements are also required for production to proceed.

The prime consultant, typically the project architect, is responsible for the review of the precast manufacturer's shop drawing submissions and coordination with the design team. The general contractor is responsible for coordination with the various trades.

A key element in the shop drawing review process is to ensure proper coordination of the work of other trades, particularly at interfaces between the precast wall panels and other building envelope assemblies and components such as windows, louvers, electrical devices and roofing materials. The location and detail of the precast anchors to the structural frame of the building should be reviewed by the structural engineer, and the details developed to maintain the integrity of the building envelope should be reviewed by the building envelope consultant.

Window shop drawings should be reviewed in conjunction with the precast shop drawings. Responsibility for continuity of thermal insulation or connection of the air barrier and vapour barrier between the precast and adjacent building envelope assemblies should be defined on the project drawings and coordinated between the trades at the time of shop drawing review. Reviewed shop drawings should be copied to all trades affected by the work. Confirmation of window sizes and window openings should be the responsibility of both the window subcontractor and the precast concrete panel subcontractor.

6.5 Plant Visits

Plant visits should be carried out by the project architect at the start of production and at various times during the production of the precast panels to observe methods and materials employed in the fabrication. The prime consultant should review the written quality control procedures established by the manufacturing plant (these may be proprietary and may need to be viewed at the precaster's facility). Documentation of material test results, either established by plant tests of raw materials or based on certified test reports from suppliers, should be available to the prime consultant on a regular basis throughout the production period.

Architects should also use these plant visits as an educational opportunity to see what is possible with precast concrete and to look at the other projects in production at the plant. Many architects will be surprised by the many opportunities available to them when using architectural precast concrete.

Post-pour inspection of the finished product should be conducted to identify non-conformances prior to shipping to the job site. The reader is directed to Section 33 of CSA A23.4 for further information regarding defects and their repair.

6.6 Mock-Ups

6.6.1 Production Approval Samples

The small samples suggested for the pre-bid conference stage are adequate to prequalify precasters, but one quarter to full size mock-ups are recommended to demonstrate materials, colour, texture, scale and patterns under changing light conditions. Mock-ups are particularly important for precast concrete wall panels with multiple finishes, textures or veneers. As concrete is a natural material, an acceptable range of colour variation should be established using a series of range samples.

Assessment of mock-ups and samples should be made at distances and orientations similar to those possible at the project site, under varied light conditions and when the mock-up is both wet and dry. Reviewing the finish of mock-up panels should be done in typical lighting with the unaided naked eye from a minimum 6 metre viewing distance.

The architect and/or an owner's representative should sign off on the approved samples.

6.6.2 Full-Scale Mock-Up on Site

Production and assembly of a full scale mock-up of the precast wall assembly is recommended prior to commencement of precast panel installation. The mock-up should include all main elements of the exterior wall assembly as well as the connections between elements. The mock-up should include details representative of all key elements in the project, including anchorage to the structural frame of the building. This may require that the mock-up include details at the ground level, intermediate slab level and at roof level.

Performance testing of the mock-up may also be required if new products or methods are employed on the project or if the client wishes to verify the installation. This should be paid for by the owner and can be included in the precast contract or done as an extra to the contract. The test results should be available to all parties providing materials to allow the parties to identify areas that may need additional attention.

Clarifications to the design details should be formalized by issuing supplementary details as site instructions or bulletins. Changes to the design details should similarly be documented and issued to all parties. It is critical that variances from the design, including dimensional relationships between elements within the exterior wall assembly, and details (and materials) for connection and continuity of the building envelope, be resolved at the mock-up stage and preferably prior to completion of the precast shop drawings and absolutely prior to the production of precast panels and final installation of the panels on the project site.

The prime consultant should accept overall responsibility for the review of mock-ups and any changes required, but the structural engineer and the building envelope consultant also play key roles in this review and the resolution of any problems. The general contractor and the sub trade contractors must also be included in this process to ensure that what is detailed can be constructed without need for further revision later.

6.6.3 Periodic Field Review during Construction

Prior to the commencement of precast panel installation, the forming contractor, with the assistance of the general contractor should survey each floor to confirm that the building dimensions conform to the drawings, to provide layout gridlines and baseline elevations and to confirm all cast in hardware required for the precast contractor is installed as per the cast in hardware drawings and placed in the correct location. If a survey of the cast in hardware is not provided by the forming contractor or general contractor claiming that all is correct, all additional survey costs to verify hardware placement should be borne by the forming contractor if any hardware is found to be incorrectly placed.

Periodic field review of the precast construction is required throughout the project to confirm general compliance to the contract documents and the accepted mock-up construction and to ensure that the specified quality is maintained. Site visits are also useful to identify unanticipated design issues or construction issues, and to permit timely resolution.

Field review of connections is also required by the precast design engineer prior to the closing of walls to confirm that connections are complete and made according to the accepted and approved connection details. Upon completion of the project, a letter certifying the connections should be issued by the precast engineer to confirm compliance to the approved details.

Field measurement of as-built joint dimensions should be conducted at critical locations to accommodate creep and shrinkage (of the building frame) due to sustained loads.

Ongoing coordination between the design team and the various trades must be continued throughout the project to ensure that all parties receive notice of any changes or revisions that may affect related work.

6.7 Quality Assurance (QA) Procedures and Documentation

As mandated by the provincial building codes through CSA standards A23.3 and A23.4, precast plants are required to be certified by an accredited certification organization such as CPCI. Precast manufacturers are audited through the CPCI Precast Concrete Certification Program twice annually, and are issued a certificate, which the designer can request. The certification expiry date is given on the certificate and certification is withdrawn if the plant falls below a required level. Plants certified by CPCI can be found online on the CPCI certified plants listing (www.precastcertification.ca). Information on the CPCI Precast Concrete Certification Program for Structural, Architectural and Specialty Precast Concrete Products and Production Processes can also be found online. The following categories are evaluated by CPCI:

1. Quality System, including but not limited to the plant QA program, the personnel, design responsibilities and project samples,

2. Production practices, including but not limited to general objectives and safety, production and curing facilities, welding, form and mould construction, hardware installation, product identification, handling, surface finishes, repairs, appearance and sealers or coatings,
3. Raw materials and accessories, including but not limited to cement, aggregates, admixtures, reinforcement and hardware, insulation and other ancillary devices,
4. Concrete, including but not limited to mix proportioning, air entrainment, structural lightweight aggregates, compatibility of mixes, water-cement ratios, storage and handling of cement, aggregates and admixtures and concrete mixing equipment requirements,
5. Reinforcement (and prestressing, as required), including but not limited to reinforcing steel, composite reinforcement, fibres, and pre-tensioning and post-tensioning equipment and procedures,
6. Quality control, such as inspection, testing, documentation and testing facilities, and
7. Product tolerances, including but not limited to product dimensions, hardware locations and finish consistency and limits.

CPCI certified precast manufacturers must develop an exhaustive Quality System Manual (QSM) for the fabrication of architectural precast panels. Once developed and approved by the Accredited Certification Organization (ACO), the precast manufacturer must follow this QSM for all products manufactured and ensure they conform to the requirements as set out in the program standards. The QSM is generally based on standards such as:

- PCI Manual MNL-117-13 Fourth Edition, Manual for Quality Control for Plants and Production of Architectural Precast Concrete Products (PCI, 2013)
- PCI Manual MNL-116-99 Manual for Quality Control for Plants and Production of Precast and Prestressed Concrete Products (PCI, 1999)
- CSA A23.4-16, Precast Concrete – Materials and Construction
- Other applicable ACI, ASTM and CSA Standards
- Special Advisories issued by the Quality Assurance Council

The CPCI standard specification (<http://www.cpci.ca/en/resources/specifications/>) for quality assurance practices calls for the materials and manufacturing procedures to be conducted as per CAN/CSA A23.1, Concrete Materials and Methods of Concrete Construction and the materials and products to be tested and verified in accordance with CAN/CSA A23.2, Test Methods and Standard Practices for Concrete. The CPCI standard specification also requires that the precast elements shall be designed to CAN/CSA A23.3, Design of Concrete Structures, and the *CPCI Design Manual*. CSA A23.4, Precast Concrete – Materials and construction is also referenced as it applies specifically to precast concrete wall panel construction.

Annex A of CSA A23.4 provides detailed information on the general responsibilities of the owner and precast panel manufacturer, as well as three options for the specific design and engineering responsibilities of the owner and the precast panel manufacturer (refer to Table A.1 of the standard). These responsibilities shall be clearly established in the contract documents. It is the precast manufacturer's responsibility in all cases to develop shop and installation drawings. The owner's choice of the three design options defines what the precast manufacturer's responsibilities are as far as design is concerned,

Consideration should be given to the inclusion of the text of Annex A in the specifications.

It is the precast manufacturer's responsibility to establish the precast panel properties to meet the performance criteria, develop and implement the quality control plan in accordance with the owner's requirements, submit the required quality documentation and to certify that the concrete complies with these criteria.

When the owner assumes responsibility for the complete drawings and specifications, including aesthetics, functional requirements, and panel dimensioning, the precaster plans the construction methods based on the design parameters provided by the owner. The precaster will need to obtain approval for any changes made to improve the economics, structural soundness or performance, or to address anticipated problems with the design parameters, however, full responsibility remains with the owner.

In any case, the precaster can be asked to verify that all plant equipment and materials used in the fabrication of the precast concrete panels meets the requirements of CSA A23.4.

CSA A23.4 provides information on testing for quality control purposes, such as, but not limited to testing for air content, compressive strength, water absorption, low density concrete and accelerated curing. The owner may request documentation confirming compliance with quality control specifications, design criteria or parameters.

6.8 LEED and Sustainability

6.8.1 Building Reuse (Materials Credit #1)

A one point LEED™ credit is offered for maintaining 100% of the building shell for reuse, consisting of the skin and frame but not the windows, interior walls and other components. Precast concrete's durability gives it a strong advantage, as architectural precast concrete wall panels can provide long service life and enable full reuse at the end of building service life.

The exact predicted service life can be hard to quantify because it depends on many variables, including weather, maintenance and type of finish. The precast concrete wall panels will endure major climatic events and resist significant abuse; however the sealant between panels may need to be replaced as determined by inspection to maintain the integrity of the building envelope.

6.8.2 Construction Waste Management (Materials Credit #2)

This credit is available for reducing construction, demolition and land-clearing waste that ends up in landfills. At least 50% of these materials must be diverted from landfills for a one point credit. The second credit is offered if 75% is diverted. This credit can be used in conjunction with the Building Reuse credit to achieve as many as four points if existing materials, such as precast concrete wall panels, are reused in the project. In that case, the materials preserved can be applied to this credit as well as to Materials Credit #1.

Concrete's inorganic composition also makes it ideal for recycling. Concrete is frequently crushed and reused as aggregate for road bases or construction fill. As with the Building Reuse credit, these options are available only in the future after the building has been constructed and is being reconsidered for other uses. Concrete's impact on these points for future use can play a role in specifications today.

Precast concrete offers other waste saving benefits. Less material is required to produce precast components because thinner sections, precise mix designs and tighter tolerances can be achieved. Less concrete is wasted because the quantities of constituent materials are tightly controlled in a precast plant. The use of less material means less natural resource extraction and less energy during manufacturing and transportation.

The waste materials from a precast plant are more likely to be recycled because concrete production takes place in one location under controlled conditions. Grey water can be recycled into future mixes. Between 5% and 20% of the aggregate in a mix can be recycled concrete aggregates. Sand used in finishing can be reused. Wood and steel forms and other materials used in casting can also be reused many times before recycling.

There is less dust and waste at the construction site because precast components are made to the exact size required and delivered when needed. There is no on-site debris from formwork, no excess rebar or concrete.

6.8.3 Recycled Content (Materials Credit #4)

This two point credit is achieved for using materials with post-consumer recycled or post-industrial recycled content. Precast concrete components can contribute to this requirement because supplementary cementitious materials can replace a portion of the cement in a mix. The use of recycled materials is growing, and will continue to grow as more designers learn about this option and its benefits.

Supplementary Cementitious Materials (SCMs) can significantly reduce the embodied energy of precast concrete products by substituting waste materials for relatively high energy consuming hydraulic cement. SCMs are mostly by-products of other industrial processes. Their judicious use in concrete production is desirable both for environmental and energy conservation as well as for the technical benefits they can provide. SCMs are added to concrete as part of the total cementitious system, either as an addition to or a partial replacement of hydraulic cement. When properly used, SCMs can enhance the following properties of concrete:

- Generally improves the workability and finishing of fresh concrete
- Reduces bleeding and segregation of fresh concrete
- Lowers the heat of hydration (beneficial in large pours)
- Improves the pumpability of fresh concrete
- Improves long term strength gain, reduces chloride permeability and absorption (especially silica fume), and reduce alkali-aggregate reactivity

The effect of replacing cement with supplementary cementitious materials on the embodied energy of concrete is appreciable. For example, a 1% replacement of cement with fly ash results in approximately a 0.7% reduction in energy consumption and environmental impact per cubic metre of concrete.

Silica Fume

Silica fume is a waste product recovered from the reduction of high-purity quartz with coal in electric arc furnaces in the production of silicon and ferrosilicon alloys. Silica fume improves the quality, strength and durability of concrete by making the concrete much less permeable to chlorides and more resistant to corrosion of the steel reinforcement.

Fly Ash

Fly ash is a pozzolan waste product collected from coal-fired power plants. Fly ash refines the pore structure of the concrete, making it more resistant to chloride penetration. Fly ash must conform to the requirements of CSA A3000 and must be specified in accordance with Table 8 in CSA A23.1.

Although fly ash offers environmental advantages, it also improves the performance and quality of concrete. Fly ash affects the plastic properties of concrete by improving workability, reducing water demand, reducing segregation and bleeding, and lowering heat of hydration. Fly ash increases strength, reduces permeability, reduces corrosion of reinforcing steel, increases sulphate resistance, and reduces alkali-aggregate reaction. Concrete with fly ash reaches its maximum strength more slowly than concrete made with only hydraulic cement.

Normally 10% to 20% of the cement can be replaced with fly ash to reduce the environmental burden of the concrete. Substitution of fly ash at levels exceeding 25% is considered to be a high volume SCM application. Care must be taken to perform appropriate testing to ensure desired performance. The use of fly ash can increase setting times. This may be an economic factor in precast concrete manufacturing if casting and stripping cannot be maintained on a daily cycle.

Designers and specification writers should consult with the precast panel manufacturer to optimize the use of fly ash to achieve the required performance prior to the project tender.

Blast Furnace Slag

Production of blast furnace slag consumes about 1/3 of the energy required to produce cement. Substitution of slag at levels exceeding 35% for the hydraulic cement in precast concrete is considered a high volume SCM application, and its suitability for intended use must be prequalified. The addition of slag cement usually results in a reduced need for water, faster setting time, improved pumpability and finishability, higher 28-day strength, lower permeability, resistance to sulfate attack and alkali-silica reactivity (ASR), and a lighter color. Not all slag is suitable for use in concrete. Blast-furnace slag must also conform to the requirements of CSA A3000 and must be specified in accordance with Table 8 in CSA A23.1.

6.8.4 Local/Regional Materials (Materials Credit #5)

A one point credit is offered when at least 20 percent of building materials are manufactured within an 800 km radius of the site. An additional point is offered when half of the regionally manufactured products are extracted or recovered within 800 km. Precast concrete meets both of these requirements in virtually all cases. Most precast plants are within 300 km of a project, and the raw materials used to produce the precast concrete components (cement, aggregate and reinforcement) are usually obtained from sources within 300 km of the precast plant. This advantage leads many designers to replace granite, stone and other imported products with precast concrete wall panels.

6.8.5 Durable Building (Regional Priority #1)

The intent of the Durable Building credit is to design and build a durable building that will minimize waste resulting from inappropriate material selection and premature deterioration of building components.

Buildings constructed from robust materials can withstand weather exposure and occupant use for a very long time.

Precast concrete's durability creates a long life cycle with low maintenance, reducing the need for maintenance and replacement during a building's life. As well, durable systems and components are prime candidates for refurbishment and continued service. Buildings constructed using precast concrete wall panels that are designed, constructed and maintained to suit the climate and exposure fit these criteria.

Predicted service life of precast concrete elements can generally meet or exceed the building design service life. While sealants have a shorter service life than precast concrete, sealant is accessible and readily replaceable, and as such precast panels meet the intent of the LEED Canada Durable Building credit. Selection of a durable exterior sealant such as silicone is a key factor in minimizing maintenance needs.

At the end of a building's useful life, up to 100% of the precast concrete panels can be reused or recycled. After removal of the reinforcement, concrete can be crushed to produce aggregates that are primarily used in pavement construction, as granular sub-base, lean-concrete sub-base and soil-cement aggregates. Recycled concrete has also been used on a limited scale as replacement aggregates in new concrete production. The extracted steel reinforcement can be recycled and made into new reinforcement.

6.8.6 Life Cycle Assessment, Environmental Impacts and Resource Measurements

In 2012, the Canadian Precast/Prestressed Concrete Institute (CPCI) published a multi-year life cycle assessment (LCA) "Life Cycle Assessment Study for Commercial Buildings" for a typical commercial building with various structural assemblies in two distinctly different Canadian climates, Toronto and Vancouver (CPCI, 2012). The LCA study was instrumental in understanding precast concrete's relative environmental performance in the context of building construction, use, and end-of-life. One of the key findings of the ISO compliant study was that operating energy was responsible for the majority of the environmental impacts for a typical commercial building. For example, over a 73-year building life cycle, more than 90% of the total primary energy (TPE) and global warming

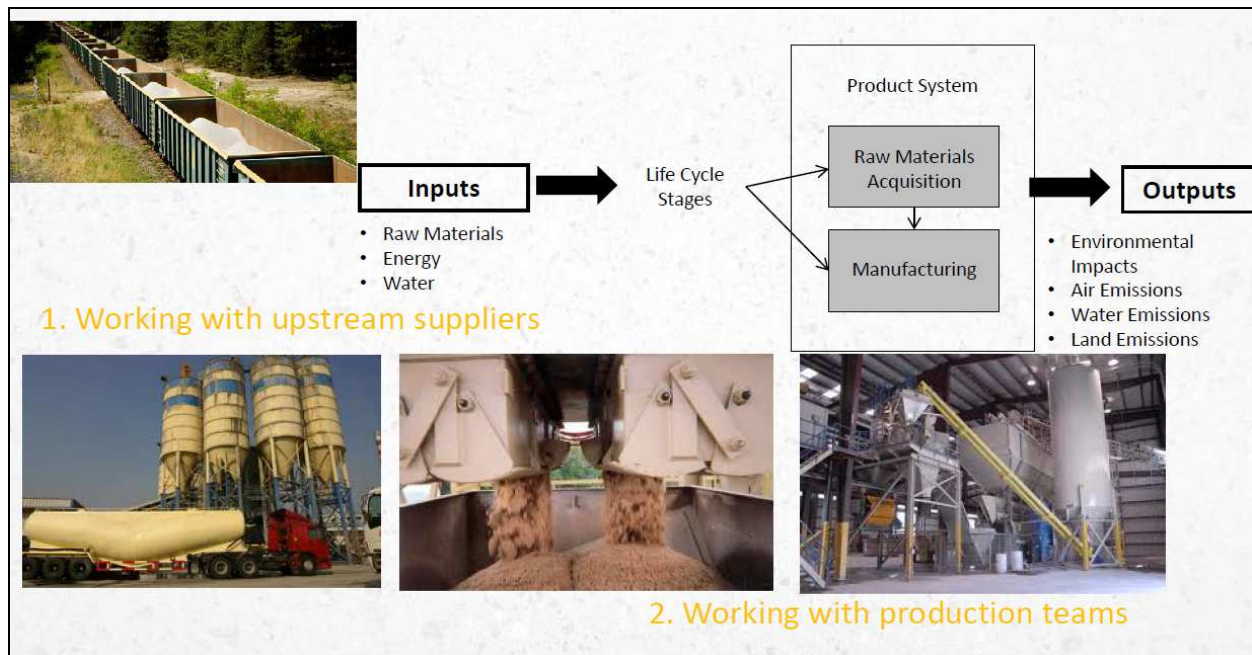

Figure 6-1: Visual Schematic of the Sustainable Plant Tracking Program showing the input materials through their life cycle stages of extraction, processing, and finally their optimization in the precast manufacturing process. Source: CPCI

potential (GWP) impacts for a building in Toronto were associated with the operation of the building. These findings were consistent with other recent studies (Verbeeck and Hens, 2010; UNEP, 2009). In addition, these studies support the sustainable movement towards net-zero construction, and the Architecture Canada 2030 Challenge. In the same study, concrete manufacturing was determined to be responsible for approximately only 9% of the GWP and TPE impacts.

In 2012, CPCI also launched the CPCI Sustainable Plant Program to benchmark the Canadian precast concrete industry’s impact on the environment in the areas of global warming, energy and water use, waste, dust and noise generation (refer to Figure 6.1). At the center of the Sustainable Plant Program is the Sustainable Precast Concrete Benchmark Calculator (v3.0), a tool that measures and quantifies the impacts of all input materials through their life cycle stages of extraction, transportation, processing, and finally through their optimization in the precast manufacturing process. Environmental impact is of particular interest to architectural projects, where long term performance and total cost of ownership are well understood in the decision-making process, but the cradle-to-construction environmental impacts have not yet been readily or clearly defined or available. The innovative tracking software enables individual manufacturers to measure their “cradle-to-gate” environmental footprint on a facility, product or client project basis (with cradle being raw material resource extraction and gate being the finished product leaving the precast plant for the construction site).

Ultimately, the precast industry is striving to reduce the environmental impact at the manufacturing level while creating a culture of sustainability. The CPCI Life Cycle Assessment Study for Commercial Buildings has helped to identify where the industry can improve its manufacturing stage life cycle impacts, with a goal to positively influence the environmental impact over the entire life of the precast product in use. This program has now been adopted by both the National Precast Concrete Association (NPCA) and Precast/Prestressed Concrete Institute (PCI) and is currently known as the North American Sustainable Plant Program. Visit www.sustainableprecast.ca for more information.

6.8.7 Environmental Product Declarations

Life cycle assessment is a more comprehensive way to look at the environmental impact of a product over its lifetime. An EPD, or Environmental Product Declaration, documents this information in a standardized format that makes the job of assessing products much easier for the designer.

With the proliferation of eco-labels and green certifications worldwide, it can be confusing determining a product's environmental attributes. Well established in other parts of the world, EPDs are starting to appear in the North American marketplace as the common methodology for assessing the potential environmental performance of a product or process. The CaGBC LEED v4 Rating System and Architecture 2030 are leading the demand for EPDs.

EPDs list all of the impacts associated with a product, from raw material extraction, processing and transportation to the manufacture of the product and transportation to the construction site. In some cases the EPD report ends at the gate of the plant, and in other cases it continues through occupancy and maintenance to the end of a product's useful life, as part of a complete system. How a product is defined by an EPD depends on the rules applied, and these rules are established by the Product Category Rules (PCR), which are distinct for each product. The end result of all of this is a standard document for all manufacturers that enables a uniform and consistent method to declare the environmental impact of their product.

EPDs can also help contribute to LEED credits and are verified by an accredited Program Operator such as ASTM International to ensure that the contents of the declaration conform to the requirements of the PCR, including the life cycle assessment. As a Program Operator, ASTM International has developed its program in conformance with ISO 14025 - Environmental Labels and Declarations - Type III Environmental Declarations - Principles and Procedures.

CPCI members are one of the first concrete manufacturers in North America to achieve a third-party verified EPD, providing comprehensive, uniform details about a product's composition and environmental impact throughout the lifecycle. CPCI partnered with the other major North American precast concrete industry associations, namely NPCA and PCI, together with ASTM International to create a set of Product Category Rules for Precast Concrete and subsequently develop Precast Concrete Environmental Product Declarations which can be found at www.sustainableprecast.ca.

CHAPTER 7 Maintenance

Precast concrete is a durable, low maintenance building material. As with all building envelope assemblies, when a simple program of inspection and maintenance is followed, precast concrete panels can meet and exceed the building's design service life. In CSA S478-1995 (r2007) *Guideline on Durability in Buildings*, there is an expectation that the building's performance will be monitored for deterioration or distress; problems will be investigated and addressed, so that the building and its systems achieve the design service life.

It is important to address issues of access to the exterior face, for window replacement, reglazing, reapplication of sealants and cleaning of the precast panels.

Annual inspection: In order to ensure the continued performance of the precast wall assembly and maintain warranty, visual inspections should be conducted. Particular attention should be paid to the sealant joints, and the surface appearance. Signs of deterioration should be documented with pictures, and a report sent to the manufacturer. Applicable defects reported during the warranty period should be remedied by the manufacturer as soon after detection as possible to limit possible deterioration of other elements.

Annual inspections are encouraged after expiration of the warranty period as well in order to promote the continued performance of the building envelope.

Suggested maintenance activities are summarized below:

Immediately after erection:

- Clean precast concrete elements.

Annual inspection during the building service life:

- Review sealant joints to ensure precast joints are properly sealed.
- Replace damaged joint sealant precast panel to precast panel and precast panel to adjacent non-precast components by:
 1. Removing the damaged joint sealant,
 2. Cleaning the substrate(s) with solvents to remove any deleterious substances (consult the sealant manufacturer to confirm appropriate solvent types),
 3. Applying primer, as required by the manufacturer, and
 4. Re-applying sealant, as per the manufacturer's instructions. There may be benefit in matching the new caulking with the existing, for compatibility purposes.

Periodic cleaning:

- Power wash precast panels every four to six years, based on environmental exposure (e.g. acid rain) to maintain its original appearance.
- If acid is used for cleaning purposes, pre-test a sample to confirm that the precast panels, and any other adjacent assemblies, will not be damaged by the cleaning process.
- If pigments are used in the concrete mix, a non-acid treatment is recommended. Follow applicable by-laws regarding the use of sand-blasting or acid-cleaning.

For all maintenance activities, ensure that access equipment does not damage precast surfaces. As well, ensure that window cleaning solution runoff is cleaned from precast units to prevent staining.

General information on periodic review of building envelopes can be found in *Protocols for Building Condition Assessment* (NRCC/IRC, 1993) and *ASTM E2270, the Standard Practice for Periodic Inspection of Building Facades for Unsafe Conditions* (ASTM, 2005). Maintenance and cleaning guidelines for precast panels can be found in *Insulated Wall Panel Technical Guide* (CPCI, 2010) (http://www.cpci.ca/en/resources/technical_publications/). The *Architectural Precast Concrete Technical Guide* (CPCI, 2009) (http://www.cpci.ca/en/resources/technical_publications/) provides guidance on how to remove stains from precast concrete surfaces.

For more information on precast building maintenance and inspection, refer to the guide *Maintenance and Inspection Manual for Precast Concrete Enclosures*, prepared by RDH Building Sciences Inc. The manual provides an inspection checklist template for architects and engineers to use when performing inspections of precast building enclosures to ensure consistency and all components are reviewed.

CHAPTER 8 Glossary

Absorbed moisture:	Moisture which is mechanically held in a material.
Absorption:	The process by which one substance (solid or liquid) takes up or dissolves another substance (liquid or gas).
Accelerator:	An admixture which, when added to concrete, mortar, or grout, increases the rate of hydration of the hydraulic cement, shortening the set time and increasing the rate of strength gain,
Adhesion:	the action, process or property of a material to stick to or bond to the surface to which it is applied.
Adhesion failure:	Failure of a compound by pulling away from the surface to which it was bonded.
Adhesion peel test:	The separation of a bond, whereby the material is pulled away from the mating surface at a 90-degree or 180-degree angle to the plane to which it is adhered.
Admixture:	A material other than water, aggregates, and portland cement that is added to the mix immediately before or during mixing.
Adsorption:	The binding of molecules or particles to a surface.
Air barrier system:	The assembly installed (in the building envelope) to provide a continuous barrier to the movement of air (NBC'95)
Air entraining agent:	An admixture for concrete or mortar which intentionally introduces minute air bubbles into concrete or mortar during mixing.
Air infiltration:	The unintentional introduction of outside air into a building through cracks in walls, windows and doors.
Anchor:	A device used to secure a building part or component to the adjoining construction or supporting member.

Architectural precast:	Precast concrete units which, through finish, shape, colour and texture, define the architectural aesthetic and function of the structure.
Backer rod:	A polyethylene or polyurethane cylindrical shaped foam material installed in the joints between building materials
Back-up:	A material placed into a joint, primarily to control the size and flow of materials.
Bead:	A material after application in a joint between two elements, irrespective of the method of application, such as caulking bead.
Blast furnace slag:	A non-metallic waste product developed simultaneously with iron in a blast furnace. It consisting of a mixture of lime, silica and alumina, the same oxides that make up portland cement, but not in the same proportion or form. It is used both in the manufacture of portland blast furnace slag cement and as an aggregate for lightweight concrete.
Bleeding / Bleed water:	A form of segregation in which some of the water in a concrete mix rises to the surface of freshly placed concrete.
Bond:	Adhesion of cement or concrete to aggregate or reinforcement, or to other surfaces.
Bond breaker:	A material, usually plastic film or foam used to prevent adhesion between two materials.
Bush-hammer:	A tool having a serrated face, used to texturize a surface and create an architectural finish on a concrete surface.
Butyl:	A synthetic rubber formed from isobutylene and isoprene.
Capillarity:	A wick-like action resulting from the forces of attraction of molecules.
Carbonation:	Reaction between the products of Portland Cement (soluble calcium hydroxides), water and carbon dioxide to produce insoluble calcium carbonate (efflorescence).
Caulk (v):	The application of a sealant to a joint or crack. A compound used for sealing that has minimum joint movement capability; sometimes called low performance sealant.
Cement, Portland:	A powdery substance made by burning, at a high temperature, a mixture of clay and limestone producing lumps called "clinkers" which are ground into a fine powder consisting of hydraulic calcium silicates. This is the main adhesive ingredient in concrete.
Cold joint:	A visible lineation which forms when the placement of concrete is delayed. The concrete in place sets prior to the next placement of concrete against it.
Compatibility:	The ability of two or more materials to exist in close and permanent association for an indefinite period with no adverse effect of one on the other.

Concrete:	A composite building material made from the combination of aggregate and cement binder.
Condensation:	The appearance of moisture (water) on the surface of an object caused by warm moist air coming into contact with a colder surface.
Construction joint:	A plane of weakness to control contraction cracking in concrete. A joint can be initiated by forming or created the in plastic or green concrete and shaped with later process.
Convection:	The transfer of heat by mass motion where air flows downward due to cooling against a cold surface and flows upward due to heating against a warm surface.
Convex bead:	Bead of compound with a convex exposed surface.
Deflection:	The degree to which an element is displaced due to an applied load.
Double wythe insulated wall panel:	A precast concrete panel where thermal insulation is sandwiched between an exterior architectural precast concrete wythe and an interior precast concrete structural wythe. They have been commonly referred to as a "sandwich panel" or an "insulated panel" in the past.
Elastomeric material:	An elastic, rubber-like substance capable of stretching and having the ability to recover to its original configuration.
Entrained air:	(See air entrainment) Microscopic air bubbles intentionally incorporated in mortar or concrete, to improve workability and durability (for increased freeze/ thaw resistance).
EPDM:	Ethylene Propylene Diene Monomer, a synthetic rubber.
Façade	A face or elevation of a building.
Face sealed:	A wall system with a single seal on its exterior surface to prevent water and air leakage.
Fenestration:	Any glass panel, window, door, curtain wall or skylight unit on the exterior of a building.
Fillet bead:	Caulking or sealant placed in such a manner that it forms an angle between the materials being joined.
Fly ash:	The finely divided residue resulting from the combustion of ground or powdered coal. Fly ash is a by-product of burning coal in coal fired power stations.
HVAC:	Heating, Ventilating and Air Conditioning (systems).
Hydraulic cement:	Cement that gains strength through a process of hydration, not drying. All portland and blended cements are hydraulic cements. "Hydraulic cement" is merely a broader term. ASTM C1157, Performance Specification for Hydraulic Cement, is a performance specification that includes portland cement, modified portland cement, and blended cements.

IGU or IG unit:	Insulating Glass unit formed by two or more panes (sheets) of glass on either side of a rigid spacer creating a hermetically sealed air space.
Modulus of elasticity:	A measure of the resistance of material to deformation. The elastic modulus, or Young's Modulus is usually given the symbol E.
Polyurethane sealant:	An organic compound formed by the reaction of a polyol with an isocyanate.
Portland cement:	(ASTM C 150) the product obtained by pulverizing clinker consisting essentially of hydraulic calcium silicates.
Post-tensioning:	A method of prestressing reinforced concrete in which the steel is stressed in tension against the hardened concrete to place the hardened concrete in compression prior loads being applied to the element due to use
Prestressed concrete:	Concrete in which stresses have been introduced prior to use which are opposite in sense to those that the structural member will be expected to carry during its use.
Pre-tensioning:	A method of prestressing reinforced concrete in which the steel is stressed tension before the concrete is placed around it and then released to create compression in the concrete after the concrete has gained sufficient strength to bond to the reinforcement and hold the stressed material in tension.
Rain screen:	A design methodology for cladding to shed water and prevent water penetration into the building envelope by creating a capillary break in the wall assembly.
R-value:	The imperial designation of thermal resistance of a system expressed in ft ² /hr/°F/Btu.
RSI-value:	The metric designation of thermal resistance of a system expressed in m ² /W/°C
Sealant:	Compound used to fill and seal a joint or opening, as opposed to a sealer which is a liquid used to seal a porous surface.
Single wythe wall panel:	A precast concrete cladding panel consisting of a single layer of precast concrete providing both the aesthetic and structural properties of the cladding. Single wythe wall panels are commonly referred to as "conventional" precast panels.
Slag:	A non-metallic waste product developed in the manufacture of pig iron, consisting of a mixture of lime, silica and alumina, the same oxides that make up portland cement, but not in the same proportions or forms. It is used both in the manufacture of portland blast furnace slag cement and as an aggregate for lightweight concrete.
Slump:	A measure of the workability and consistency of plastic concrete. (See ASTM C143).
Soffit:	The underside of a construction element in a building.
Spandrel panel:	A horizontal opaque panel used to cover other building elements that would otherwise have a negative impact on the aesthetics of a building facade.

Stack effect:	The movement of air or gasses into or out of buildings or building spaces resulting from the buoyancy of warm air.
STC (Sound Transmission Class):	A single number rating derived from individual transmission losses at specified test frequencies. It is used for interior walls, ceiling and floors.
Vapour barrier:	The elements installed (in the building envelope) to control or resist the diffusion of water vapour (NBC'95)
Venting:	Providing circulation of air or ventilation between various layers in a wall assembly.
Water-Cement ratio:	The ratio of the amount of water, exclusive of that absorbed by the aggregates, to the amount of cementing materials in a concrete mix.
Weeps (or weep holes):	Drain holes or slots in the panel joints to allow the evacuation of water.

CHAPTER 9 References

- ASTM. 2005. ASTM E2270-05, *Standard Practice for Periodic Inspection of Building Facades for Unsafe Conditions*. West Conshohocken: American Society for Testing and Materials.
- ASTM. 2010. ASTM C793-05(2010), *Standard Test Method for Effects of Laboratory Accelerated Weathering on Elastomeric Joint Sealants*. West Conshohocken: American Society for Testing and Materials.
- ASTM. 2010. ASTM C794-10, *Standard Test Method for Adhesion-in-Peel of Elastomeric Joint Sealants*. West Conshohocken: American Society for Testing and Materials.
- ASTM. 2011. ASTM C1135-00(2011), *Standard Test Method for Determining Tensile Adhesion /Properties of Structural Sealants*. West Conshohocken: American Society for Testing and Materials.
- ASTM. 2013. ASTM D412-06a(2013), *Standard Test Methods for Vulcanized Rubber and Thermoplastic Elastomers – Tension*. West Conshohocken: American Society for Testing and Materials.
- ASTM. 2013. ASTM C719-13, *Standard Test Method for Adhesion and Cohesion of Elastomeric Joint Sealants under Cyclic Movement*. West Conshohocken: American Society for Testing and Materials.
- ASTM. 2010. ASTM C794-10 *Standard Test Method for Adhesion-in-Peel of Elastomeric Joint Sealants*. West Conshohocken: American Society for Testing and Materials.
- ASTM. 2013. ASTM C1521-13, *Standard Practice for Evaluating Adhesion of Installed Weatherproofing Sealant Joints*. West Conshohocken: American Society for Testing and Materials.
- ASTM. 2011. ASTM C510 - 05a(2011), *Standard Test Method for Staining and Color Change of Single- or Multi-component Joint Sealants*. West Conshohocken: American Society for Testing and Materials.
- ASTM. 2012. ASTM C1248-08(2012), *Standard Test Method for Staining of Porous Substrate by Joint Sealants*. West Conshohocken: American Society for Testing and Materials.
- ASTM. 2013. ASTM C1193, *Standard Guide for Use of Joint Sealants*. West Conshohocken: American Society for Testing and Materials.
- Cement Association of Canada. 2006. *Concrete Design Handbook*, 3rd ed. Cement Association of Canada, Ottawa, ON.
- CGSB. 1987. CAN/CGSB 19.13-M87, *Sealing Compound, One Component, Elastomeric, Chemical Curing*. Gatineau: Canadian General Standards Board.
- CGSB. 1990. CAN/CGSB 19.24-M90, *Multi-component, Chemical-Curing Compound*. Gatineau: Canadian General Standards Board.

- CPCI. 2017. *Design Manual, Precast and Prestressed Concrete*, 5th edition. Ottawa: Canadian Precast/Prestressed Concrete Institute.
- CPCI. 2009. *Architectural Precast Concrete Technical Brochure*. Ottawa: Canadian Precast/Prestressed Concrete Institute, 535 p. Available at: http://www.cpci.ca/downloads/national_architectural_2009_2009.pdf
- CPCI. 2010. *Insulated Wall Precast Concrete, Technical Brochure*. Ottawa: Canadian Precast/Prestressed Concrete Institute. Available at http://www.cpci.ca/downloads/national_insulated_2010_20096.pdf
- CPCI. 2004. *Architectural Precast Concrete Colour and Texture Selection Guide*. Ottawa: Canadian Precast/Prestressed Concrete Institute. Available at http://www.cpci.ca/en/resources/technical_publications/
- CPCI. 2011. *Life Cycle Assessment of Precast Concrete Commercial Buildings*, CPCI Technical Research Bulletin #12-01. Ottawa: Canadian Precast/Prestressed Concrete Institute. Available at http://www.cpci.ca/downloads/Life_Cycle_Assessment_of_Precast_Commercial_Buildings.pdf
- CPCI. 2012. *CPCI Life Cycle Assessment Study for Commercial Buildings*. Ottawa: Canadian Precast/Prestressed Concrete Institute.
- CPCI, 2013. *Architectural Precast Concrete Specification*. Ottawa: Canadian Precast/Prestressed Concrete Institute. Available at <http://www.cpci.ca/en/resources/specifications/>
- CSA. 1995. CSA S478-95 (R2007), *Guideline on Durability in Buildings*. Toronto: Canadian Standards Association.
- CSA. 2000. CAN/CSA A251-00, *Qualification Code for Architectural and Structural Precast Concrete Products*. Toronto: Canadian Standards Association.
- CSA. 2014. CAN/CSA-A23.3-14), *Design of Concrete Structures*. Toronto: Canadian Standards Association.
- CSA. 2008. CAN/CSA A3000-08, *Cementitious Materials Compendium*. Toronto: Canadian Standards Association.
- CSA. 2014. CSA A23.1-14, *Concrete Materials and Methods of Concrete Construction*. Toronto: Canadian Standards Association.
- CSA. 2014. CSA A23.2-14, *Test Methods and Standard Practices for Concrete*. Toronto: Canadian Standards Association.
- CSA. 2016. CSA A23.4-16, *Precast Concrete – Materials and Construction*. Toronto: Canadian Standards Association.
- Gustaferro, A. H. and Abrams, M. S. 1975. *Fire Tests of Joints between Precast Wall Panels: Effect of Various Joint Treatments*. Chicago: PCI Journal, vol. 20, no. 5, Sept.-Oct., pp. 44-64, as cited in CPCI, 2007.
- Hutcheon, N.B. 1963. *Canadian Building Digest-48: Requirements for Exterior Walls*.
- Kerr, D. 2004. *Keeping Walls Dry*. Ottawa: Canada Mortgage and Housing Corporation.
- Masonry Council of Canada. 1982. *Guide to Energy Efficiency in Masonry and Concrete Buildings*. Downsview, ON.
- Morrison Hershfield. 2011. *Thermal Performance of Building Envelope Details for Mid- and High-Rise Buildings* (1365-RP). Atlanta: American Society of Heating, Ventilating and Air-Conditioning Engineers.
- Neville, A.M. 2011. *Properties of Concrete*, 5th ed. Essex: Pearson Education Limited.
- Ontario Masonry Contractor Association. 1976. *Masonry Design Handbook*.
- NRCC/IRC. 1993. *Protocols for Building Condition Assessment*. Ottawa: National Research Council of Canada, Institute for Research in Construction.
- NRCC. 2015. *National Building Code of Canada*. Ottawa: National Research Council of Canada.

- PCI. 2013. MNL117-13. *Manual for Quality Control for Plants and Production of Architectural Precast Concrete Products*, 3rd ed. Chicago: Precast/Prestressed Concrete Institute.
- PCI. 1999. MNL116-99, *Manual for Quality Control for Plants and Production of Precast and Prestressed Concrete Products*, 4th ed. Chicago: Precast/Prestressed Concrete Institute.
- RDH Building Science Corporation. 2013. *High Performing Precast Concrete Building Enclosures: Rain Control*. Waterloo, ON: Building Science Corporation, Waterloo.
- ULC. 2007. *Standard Methods of fire Endurance Tests of Building Construction and Materials*. Toronto: Underwriters Laboratory of Canada.
- UNEP. 2009. *Buildings and Climate Change*. Sustainable Buildings & Climate Initiative. Paris: United Nations Environment Programme.
- Verbeeck, G. and H. Hens. 2010. *Life cycle inventory of buildings: A contribution analysis*. Building and Environment, vol. 45.

CHAPTER 10 Bibliography

Architectural and Building Science References:

High Performing Precast Concrete Building Enclosures:
Rain Control Guide

<http://downloads.cpci.ca/57/downloads.do>

Meeting and Exceeding Building Code Thermal
Performance Requirements Guide

<http://downloads.cpci.ca/491/download.do>

Maintenance and Inspection Manual for Precast
Concrete Building Enclosures Guide

<http://z.cpci.ca/?d=m3k2f0p9k>

Architectural Precast Concrete Technical Guide

<http://downloads.cpci.ca/61/downloads.do>

Insulated Wall Panel Technical Guide

<http://downloads.cpci.ca/59/downloads.do>

Colour and Texture Selection Guide

<http://downloads.cpci.ca/65/downloads.do>

Architectural Precast Concrete Repair Guide

<http://downloads.cpci.ca/492/download.do>

Technical Bulletins and Manuals:

CPCI 5th Edition Design Manual

http://www.cpci.ca/en/resources/design_manual/

Designing with Precast Concrete: Structural Floor &
Roof Systems Guide

<http://downloads.cpci.ca/62/downloads.do>

Designing with Precast Concrete: Structural Solutions
Guide

<http://downloads.cpci.ca/63/downloads.do>

Sustainability Resources:

EPD – Architectural and Insulated Wall Panels

<http://downloads.cpci.ca/418/download.do>

EPD – Structural Precast Concrete Products

<http://downloads.cpci.ca/419/download.do>

EPD - Underground Precast Concrete Products

<http://downloads.cpci.ca/420/download.do>

Life Cycle Assessment of Precast Concrete Commercial
Buildings

<http://downloads.cpci.ca/71/downloads.do>

North American Precast Concrete Sustainable Plant
Program

<http://downloads.cpci.ca/368/download.do>



Top left: William's Court, Ottawa, Ontario—By Alcaide Webster Architects • **Top right:** École Espace Jeunesse, Saint-Charles-Borromée, Québec—By Leclerc associés | architectes • **Lower left:** Simons Park Royal Store, Vancouver, British Columbia—By LEMAYMICHAUD Architecture Design • **Lower right:** Champagne Quarry Park, Calgary, Alberta—By Gibbs Gage Architects



**Canadian Precast/Prestressed
Concrete Institute**

PO Box 24058 Hazeldean
Ottawa, ON, Canada K2M 2C3
Tel: 613.232.2619
Toll free: 877.937.2724
www.cpci.ca



M.E. Hachborn Engineering

44 Cityview Circle
Barrie, ON, Canada L4N 7V2
Tel: 647-861-5348

Disclaimer: This Guide is not intended to replace professional expertise. When the information contained within this Best Practice Guide is used as guidance and incorporated into the design of buildings, it must be reviewed by knowledgeable engineering and building envelope professionals and reflect the specific and potentially unique conditions and design parameters of each building. Readers are advised to evaluate the information, materials and techniques cautiously for themselves and to consult appropriate professional resources to determine whether information, materials and techniques are suitable for their application. The drawings and text are intended as general best practice guidelines only. The project and site specific factors of climate, cost, aesthetics, and so on must be taken into consideration. Use of the Guide does not relieve designers of their responsibility to comply with local building codes, standards and bylaws with respect to the design and construction of the building envelope.