

4.7 JOINTS

4.7.1 General

The successful performance of a building exterior is frequently defined by its ability to keep rain and the elements outside, away from the building's occupants. Precast concrete panels are relatively impermeable to water. Moisture will not penetrate through precast concrete panels. The joints between precast concrete panels or between panels and other building materials must be considered to prevent water and air penetration through the building envelope. The design and execution of these joints is therefore of the utmost importance and must be accomplished in a rational, economical manner. Joint treatment also has an effect on the general appearance of the project. To ensure the joint and sealant give the desired performance, selecting the right product, appropriate joint design, and proper surface preparation and application technique is required.

The penetration of moisture into a building envelope may enter directly (through an opening), by gravity, capillary action, and as a result of the mean (steady state) air pressure difference across the wall.

Joint sealants are fully exposed to the major agents of aging and deterioration—ultraviolet light and thermal cycling. High-performance sealants with a low modulus and high movement capability must be used to ensure quality long-term performance. In new construction, labor to material costs are typically 4 to 1, while in renovation/rehabilitation the ratio may be 8 to 1 or more.

Joints are required to accommodate changes in wall panel or structure dimensions caused by changes in temperature, moisture content, or deflection from applied design loads. The joints between panels are normally designed to accommodate local wall movements rather than cumulative movements. Sealants subjected to volume change movements, either horizontally or vertically at building corners, at adjacent non-precast concrete construction, or at windows not having similar movements must be given special consideration. Some wall designs handle water properly in two-dimensional blueprints, but fail in three-dimensional reality. Isometric drawings should be used to show the proper intersection of horizontal and vertical seals. These intersections are a prime source of sealant problems.

4.7.2 Types of Joints

Joints between precast concrete wall units may be divided into three basic types: one-stage, two-stage, and expansion joints.

One-Stage joint—As its name implies, the one-stage (face-sealed) joint has a single line of caulking for weatherproofing. This is normally in the form of a gun-applied sealant close to the exterior surface of the precast concrete panel (Fig. 4.7.1).

The principal advantages of face-sealed joints are their simplicity, ease of installation, and almost universal suitability for normal joints between precast concrete panels. No grooves or special shapes are necessary. Thus, one-stage joints are normally the most economical with regard to initial cost. However, the economics may change when maintenance costs are included in the evaluation. One-stage joints provide adequate air leakage and water penetration control in most climates. Their performance depends greatly on the quality of sealant materials, the condition of joint surfaces, quality of field installation, and the overall wall design.

Because sealants are subject to deterioration from the elements and ultraviolet (UV) exposure, it is recommended that the sealant be set back into the joints by using recessed joints. This partially protects the sealant from rain, wind, and UV light.

Two-Stage joint—Watertightness of sealant joints can be improved by installing a second line of sealant in each joint. The inner seal is placed inside the joint, generally from the exterior, and recessed a minimum of 2 to 2½ in. (50 to 63 mm) from where the back of the front sealant and backing will be located or to the back of insulation in a sandwich (insulated) wall panel. This layer provides redundancy in the system, as it is fully protected from weather and UV exposure by the outer layer of sealant, which is installed in the normal manner.

This approach requires the installation of ¾ in. (10 mm) weep openings in the exterior seal to allow water contained by the inner seal to exit the cavity between joint seals. Near the junction of the horizontal and vertical joints, the inner seal must turn out to the plane of the exterior seal at regular intervals to force water out of the joint (Fig. 4.7.2). This termination requires care in detailing and construction. Failure to provide these weep openings results in trapped water within the joint and ponding against both seals; this accelerates deterioration of the sealant material and its bond to the substrate.

These joints are based on the open rainscreen principle. They are sometimes known as ventilated or pressure equalization joints and are favored for exterior wall construction in Canada. The rainscreen principle is based on the control of the forces that can move water through small openings in a face-sealed wall system, rather than the elimination of the openings themselves.

These joints have two lines of defense for weatherproofing. The typical joint consists of a rain barrier near the exterior face and an air retarder close to the interior face of the panel. The rain barrier is designed to shed most of the water from the joint, and the wind-barrier or air retarder is the demarcation line between outside and inside air pressure.

Openings in the rain barrier allow air to rapidly enter until the pressure inside the chamber is equal to the wind pressure acting against the outer wall, which prevents water from entering the chamber. The pressure difference across the exterior layer is essentially zero, and wind pressure is transferred to the inner, airtight layer. Rain does not penetrate to the air chamber and, subsequently, to the interior of the building because there is no wind pressure forcing it through the exterior layer. Any moisture entering the joint will cling to the joint walls and then be drained out by the transverse seal.

The airtightness of the air retarder is critical in governing the speed at which pressure equalization occurs. Pressure equalization must take place almost instantaneously for a rainscreen wall to be effective. The size of vent opening must reflect the size of the joint to be pressure equalized.

Typical details of two-stage vertical joints are shown in Figs. 4.7.2 and 4.7.3. This system is especially applicable to high-rise buildings subject to severe climatic exposure (greater than 5000 degree days). The warm, moist air moving from the building interior to the exterior usually carries moisture, which could cause condensation. Air must be prevented from contacting cold surfaces in the wall. In northern climates, thermal bridges can occur and allow condensation to form a buildup of frost in or on the walls, which may be thought to be a failure of the joint sealant. This frost later can melt and run back inside the building, giving the impression that the building is leaking.

Water either from penetration or condensation in the joint should be drained from the joint by proper sealant installations. The second line of sealant should be brought to the front face at regularly spaced intervals along the height of vertical joints, usually near the junction of the horizontal and vertical joints at each floor level. Therefore, if any moisture does come out of the system, it will run down the face of the joint sealant and not over the face of the panels.

A spacing of two or three stories may be sufficient for low-rise buildings and in areas of moderate wind velocities. Factors to consider when using two-stage joints are:

1. Higher initial cost due to labor and materials required for their successful application.
2. Sealants are not easily placed at the back of the two-stage joint unless 1 to 1³/₈ in. (25 to 35 mm) joints are used. Therefore, conscientious workers or intensive supervision throughout the installation procedure is necessary, because inspection of the completed installation is difficult.

Panel configurations and joint widths should permit a careful applicator to successfully install both lines of sealant from the exterior. The special tools required may include an extension for the nozzle of the caulking gun and a longer tool for tooling the interior sealant.

The architect, precaster, erector, and sealant applicator must all understand the function of the two-stage joints if optimum results are to be achieved. The dimensions of the joints must be maintained at all times. The most common mistake in the installation of two-stage joints is leaving gaps in the air seal.

4.7.3 Expansion Joints

Cumulative movements, as well as differential expansion movement of adjacent wall materials, are generally taken by specially designed expansion joints. Because an expansion joint may have to accommodate considerable movement, it should be designed as simply as possible. Although this might result in an appearance somewhat different from a normal joint, the architect is urged to either treat it as an architectural feature or simply leave it as a different, but honest, expansion joint.

Seismic seals are a special case of expansion joints. Such joints are generally quite large and are used between new and existing buildings to protect the joint from moisture and allow the structures to move from thermal expansion, wind drift, and seismic motions without damage. Seismic joints are designed to accommodate both vertical and horizontal movement. They are available in sizes from 2 to 12 in. (50 to 305 mm). Wider openings can be accommodated by joining seal sizes together.

Materials for expansion joints must be chosen for their ability to absorb appreciable movement while performing their primary function of controlling the movement of moisture and air. Figure 4.7.4 shows bellows-type expansion seals of neoprene that accommodate thermal movement and seismic movement. Joints must be designed first for weather protection longevity, then for movement, and finally for appearance. In most cases, this requires that special gasket materials be used, rather than sealants. Otherwise, the requirements for expansion joints are similar to those listed previously for other joints.

4.7.4 Number of Joints

The number of joints in the architectural design should be minimized. This will result in a lower overall-cost for the joints, potentially lower maintenance costs, and will increase economy by working with larger panels.

Limiting panel sizes to minimize movements in the joints is not recommended. It is generally more economical to select larger panels and design the joints and sealants to allow for anticipated movements. Optimum panel size should be determined by erection conditions, available handling equipment, and local transportation limitations as to panel weight and sizes (see Section 3.3.9).

If the desired appearance demands additional joints, false joints may be used to achieve a more balanced architectural appearance. In order to match appearance of the two joints, the finish of the false joints should simulate the gaskets or sealants used in the real joints. Caulking false joints adds unnecessary expense.

4.7.5 Location of Joints

Joints are simpler to design and execute if they are located at the maximum panel thickness. If there are any ribbed projections at the edges of the panels, joints should be placed at this location. Ribs at the edges improve the structural behavior of the individual unit. Also, panel variations—possible warping or bowing—are less noticeable when the joints are placed between ribs than when the joints are located in flat areas. However, complete peripheral ribs are not recommended because they are likely to cause localized water runoff resulting in unsightly staining. Instead, ribs should be placed at vertical panel edges. If the ribs are too narrow to accommodate joints, the full rib may be located in one panel only.

Vertical joints should be located on grid lines. Horizontal joints should be near, but above, floor lines. The designer should allow the pre-caster to optimize panel sizes for economy with false joints, if necessary. The location of joints between precast concrete panels should be considered as an integral part of the evaluation of economical fastening of the units.

Locating and detailing joints (real or false) is an important factor in creating weathering patterns for a building. Joints should be made wide and recessed to limit unexpected weathering effects (Fig. 4.7.5). Recessed joints screen the joint from rain by providing a dead-air space that reduces air pressure at the face of the sealant. Also, the joint profile channels the rain runoff, helping to keep the building façade clean from unsightly runoff patterns. The designer should determine where the water will finally emerge. Set-backs should be provided at window perimeters and other vulnerable joints in the wall system to reduce the magnitude and frequency of water exposure.

Figure 4.7.6 shows an elevation where some of the false vertical joints, into which water is channeled, discharge this water over a vertical concrete surface with fewer joints than at higher levels. This causes a marked washing effect at termination of the joint; the water should be directed until it reaches the ground or a drainage system.

Joints in forward-sloping surfaces are difficult to weatherproof, especially if they collect snow or ice. This type of joint should be avoided, whenever possible. When forward sloping joints are used, the architect should take special precautions against water penetration.

All joints should be aligned, rather than staggered, throughout their length (Fig. 4.7.7). Non-aligned joints subject sealants to shear forces in addition to the expected compression or elongation forces. The additional stress may cause sealants to fail. In addition, non-aligned joints force panels to move laterally relative to each other, inducing high tensile forces.

4.7.6 Width and Depth of Joints

Joint width must not only accommodate variations in the panel dimensions and the erection tolerances for the panel, but must also provide a good visual line and sufficient width to allow for effective sealing.

The performance characteristics of the joint sealant should be taken into account when selecting a joint size. Joints between precast concrete units must be wide enough to accommodate anticipated thermal expansion, as well as other building movements and proper sealant installation. Joint tolerances must be carefully evaluated and controlled if the joint sealant system is to perform within its design capabilities. When joints are too narrow, bond or tensile failure of the joint sealant may occur and/or adjacent units may come in contact and be subjected to unanticipated loading, distortion, cracking, and local crushing (spalling).

Joint widths should not be chosen for reason of appearance alone, but must relate to panel size, building tolerances, joint sealant materials, and adjacent surfaces. The required width of the joint is determined by the temperature extremes anticipated at the project location, the movement capability of the sealant to be used, the temperature at which the sealant is initially applied, panel size, fabrication tolerances of the precast concrete units and panel installation methods. The following factors take precedence over appearance requirements:

1. **Temperature extremes and gradients.** The temperature range used when selecting a sealant must reflect the differential between seasonal extremes of temperature and temperature at the time of sealant application. Concrete temperatures can and normally will vary considerably from ambient air temperatures because of thermal lag. Although affected by ambient air temperatures, anticipated joint movement must be determined from anticipated concrete panel temperature extremes rather than ambient air temperature extremes.
2. **Sealant movement capability.** A sealant's performance within joints is rated as the allowable movement expressed as a percentage of the effective joint width. The minimum design width of a panel joint must take into account the total anticipated expansion and con-

traction movement of the joint and the movement capability of the sealant. This evaluation should include volume changes from creep, shrinkage, and temperature variations.

PCI Design Handbook supplies figures for estimating volume changes directly related to the size of the panel. Most drying shrinkage occurs in the first weeks following casting, and creep normally levels out after a period of months. For these reasons, movements caused by ambient air temperature variations are more important than those caused by shrinkage. For loadbearing panels, the effect of creep may be cumulative, thus may be more important.

Many factors may be involved in actual building joint movement. These include, but are not limited to, mass of material, color, insulation, building load, building settlement, method of fastening and location of fasteners, differential heating due to variable shading, thermal conductivity, differential thermal stress (bowing), building sway, and seismic effects. Material and construction tolerances that produce smaller joints than anticipated are of particular concern.

Tolerances in overall building width or length are normally accommodated in panel joints, making the overall building size tolerance an important joint consideration. Where a joint must match an architectural feature (such as a false joint), a large variation from the theoretical joint width may not be acceptable and tolerances for building lengths may need to be accommodated at the corner units.

A practical calculation of panel joint size can be made as follows, as shown in ASTM C1193 and C1472:

$$J = \frac{100A}{8} + B + C$$

where:

J = minimum joint width, in.

X = stated movement capability of the sealant, in percent

A = calculated movement of panel from thermal changes = (coefficient of thermal expansion) (change in temperature) (panel length)

B = material construction tolerances

C = seismic or other considerations as appropriate

Example: Concrete panels of 30 ft (9.1 m) in length, expecting a temperature change in the concrete of 60 °F (33 °C) from sealant installation temperature, with a material or construction tolerance of 0.25 in. (6 mm), are to be sealed with a sealant having ±50% movement capability (as determined by ASTM C719). The coefficient of thermal expansion of the concrete is 6×10^{-6} in./in./°F. The calculated movement of the panel from thermal change is as follows:

$$A = (6 \times 10^{-6} \text{ in./in./}^\circ\text{F}) (60 \text{ }^\circ\text{F}) (360 \text{ in.}) = 0.130 \text{ in.} \\ (3 \text{ mm})$$

$$X = 50\%$$

$$B = 0.25 \text{ in. (6 mm)}$$

No seismic considerations, (C = 0).

The calculated minimum joint width is as follows:

$$J = \frac{(100)(0.130 \text{ in.})}{50} + 0.25 \text{ in.} = 0.51 \text{ in. (13 mm)}$$

To provide optimum quality for the installation and performance of sealants, the architect should specify a minimum panel joint width of not less than $\frac{3}{4}$ in. (19 mm). This is the minimum nominal joint width needed to adequately account for production and erection tolerances and still maintain an effective minimum joint width that can be caulked. The use of larger joints at reentrant corners and mitered panels at outside corners helps to relieve the possibility of impact between panels under large drifts in high seismic areas. It is also important that the joint between precast concrete panels and window frames also maintains the same nominal joint width. Corner joints may be $1\frac{1}{4}$ in. (30 mm) wide to accommodate the extra movement and bowing often experienced at this location. A minimum joint width of $\frac{3}{4}$ in. (19 mm) also is recommended for two stage joints to allow sufficient space for insertion of the interior seal with a 1 in. (25 mm) joint width recommended for insulated panels.

The required sealant depth is dependent on the sealant width at the time of application. The optimum sealant width/depth relationships are best determined by the sealant manufacturer, however, generally accepted guidelines are:

1. For joints designed for $\frac{3}{4}$ to 1 in. (19 to 25 mm) width: The sealant depth should be equal to one half the width. The sealant should

have a concave shape providing greater thickness at the panel faces. The sealant should have a minimum $\frac{1}{4}$ in. (6 mm) contact with all bonding surfaces to ensure adequate surface adhesion.

2. For joints greater than 1 in. (25 mm) wide: Sealant depth should be limited to $\frac{1}{2}$ in. (13 mm) maximum, preferably $\frac{3}{8}$ in. (10 mm). For sealant widths exceeding 2 in. (50 mm), the depth should be determined by consultation with the sealant manufacturer.

The depth of the sealant should be controlled by using a suitable sealant backing material. To obtain the full benefit of a well-designed shape factor, the backing material must also function as a bondbreaker (Fig. 4.7.1). When it comes to sealant depth, more is not better. If too much sealant is applied, the stresses on the sealant bead are magnified and the chance of premature debonding at the precast concrete interface is increased. If the bead is too shallow, there may be insufficient material to accommodate the joint movement and the sealant will split.

4.7.7 Sealant Materials and Installation

The most common joint materials are sealants meeting ASTM C920. These sealants are used in both one-stage and two-stage joints. If used as an air seal, they may be applied from the front provided joint width and depth permit, or from the interior if access to the joint is not blocked by edge beams or columns.

Designers should consult with the various sealant suppliers to ensure they are specifying an appropriate sealant for the specific needs of the project, as well as the sealant's proper installation. For a comprehensive discussion of joint sealants used between wall panels, refer to ASTM C1193, *Standard Guide for Use of Building Sealants*. Table 4.7.1 provides a list of common sealants and their qualities. Non-staining joint sealants should be selected to prevent the possibility of bleeding and heavy dirt accumulation, which are common problems with sealants having high plasticizer contents. Also, care should be taken to avoid sealants that collect dirt as a result of very slow cure or long tack-free time. Dirt accumulation is more a function of specific product formulation rather than generic sealant type.

When specifying a sealant, a current sample warranty should be obtained from the manufacturer and the contents studied to avoid uncalculated risks. The warranty period for a polyurethane material can be up to 10 years, and up to 20 years for a silicone. This doesn't imply that the sealant will deteriorate during that time. Some polyurethane-based products maintain their appearance and integrity for more than 15 years. Warranties can be written to cover either the material or the material and the labor needed to replace them. The specifier should be familiar with the available sealants and associated warranties prior to selecting a sealant for the building.

The following characteristics should be considered when making the final selection of sealants from those with suitable physical (durability) and mechanical (movement capability) properties:

1. Adhesion to different surfaces—concrete, glass, or aluminum.
2. Surface preparation necessary to ensure satisfactory performance—priming, cleaning, and drying.
3. Serviceable temperature range.
4. Drying characteristics—dirt accumulation, susceptibility to damage due to movement of joint while sealant is curing.
5. Puncture, tear, and abrasion resistance.
6. Color and color retention.
7. Effect of weathering—water and ultraviolet (UV) light—on properties such as adhesion, cohesion, elasticity.
8. Staining of adjacent surfaces caused by sealant or primer.
9. Ease of application.
10. Environment in which the sealant is applied.
11. Compatibility with other sealants to be used on the job.
12. Long term durability.
13. Life expectancy.

The sealants used for specific purposes are often installed by different subcontractors. For example, the window subcontractor normally installs sealants around windows, whereas a different subcontractor typically installs sealants between panels. The designer must select and coordinate all of the sealants used on a project for chemical compatibility and adhesion to each other. In general, contact between different sealant types should be avoided by having one sealant contractor do both panel and window sealant application with compatible materials.

The recommendations of the sealant manufacturer should always be followed regarding mixing, surface preparation, priming, application life, and application procedure. Good workmanship by qualified sealant applicators is the most important factor required for satisfactory performance. Sealant installation should be specified to meet at least the requirements of ASTM C1193.

Prior to sealant application, the edges of the precast concrete units and the adjacent materials must be sound, smooth, clean, and dry. They must also be free of frost, dust, laitance, or other contaminants that may affect adhesion, such as form release agents, retarders, or sealers. It may be more economical and effective to prepare joint surfaces prior to erection if a large number of units require surface preparation. It may also be desirable to conduct pre-project adhesion tests in accordance with ASTM C794, "Test Method for Adhesion-in-Peel of Elastomeric Joint Sealants," and field adhesion tests using ASTM C1521, "Standard Practice for Evaluating Adhesion of Installed Weatherproofing Sealant Joints," to determine the adhesion of the sealant with each contact surface. Adhesion (ASTM C794 or C1521) and stain testing (ASTM C510 or C1248) of the substrates and sealants in the early project planning stage of a building are recommended by most sealant manufacturers. This early testing will prevent most problems before they start and will give the construction team the assurance of a problem-free job.

Even when performed on a limited basis, inspecting sealants during installation significantly improves the probability they will be installed in accordance with the contract documents. Performing this evaluation early in the project provides a method for obtaining feedback on installation workmanship. This way, modifications or corrections can be implemented before any problem becomes widespread.

ASTM C1521 provides guidance for two tests. The first is non-destructive, and consists of applying pressure to the surface of the sealant at the center of the joint and the bond line with a probing tool. The second procedure involves removing sealant to evaluate adhesion and cohesion. The latter test offers tail and/or flap procedures, depending on whether similar or different substrates are present on adjacent surfaces of the sealant joint. The sealant pulled from the test area should be repaired by applying new sealant to the test area. Assuming good adhesion was obtained, use the same application procedure to repair the areas as was used to originally seal them. Care should be taken to ensure that the new sealant is in contact with the original sealant so that a good bond between the new and old sealants will be obtained.

ASTM C1521 can be used to evaluate installed sealant during mockups, at the start of work to confirm application methods, and throughout the work to confirm installation consistency. ASTM C1521 provides guidelines for the frequency of destructive testing when evaluation is part of a quality control program for a new installation. All results should be recorded, logged, and sent to the sealant applicator and manufacturer for warranty issuance.

In the construction of a mockup for water penetration testing, the actual field construction techniques must be used. If a leak develops, which usually occurs at the window to precast concrete interface, the details need to be examined and modified. Putting more sealant on to make the system pass the test is not realistic, as this will generally not occur during construction.

Sealants that chemically cure should not be applied to wet or icy surfaces, as they may cure or set before they can bond to the concrete surface. Some methyl methacrylate resin sealers inadvertently sprayed in the joints may peel away from the concrete surface, leaving a void between sealant and concrete. Silicone water repellents in the joints may prevent adhesion of sealants to the concrete surface. Therefore sealant/sealer compatibility should be verified. Abrasion cleaning using a stiff wire brush, light grinding, or sandblasting followed by air blowing may be necessary to remove surface contaminants. The sealant should be cured 14 days before applying water repellents. Care should be taken to caulk first, as sealer may prevent proper adhesion of sealant.

Also, before caulking, the joint may require solvent cleaning with a lint-free cloth dampened with an acceptable cleaning-grade solvent followed by wiping with a dry cloth. Isopropyl alcohol (IPA) is soluble in water and may be appropriate for winter cleaning, as it helps in removing condensation and frost by picking up surface moisture as it evaporates. Xylene and toluene are not soluble in water and may be better suited for warm weather cleaning. *Follow the solvent manufacturer's safe handling recommendations and local, state, and federal regulations regarding solvent usage.*

Sometimes, smooth concretes that are very shiny exhibit a "skin" on the surface. The skin may peel off, leaving a gap between it and the concrete after the joint sealant has been applied to the concrete. It may be necessary to remove the skin by using a stiff wire brush followed by a high-pressure water rinse. The joint must be dry before applying the sealant. Wet concrete should be allowed to dry for at least 24 hours, under good drying conditions, before applying sealant or primer.

The caulking gun should have a nozzle of proper size and should provide sufficient pressure to completely fill the joints. An extension for the nozzle of the caulking gun and a longer tool for tooling the inner seal of a two-stage joint are necessary. Joint filling should be done carefully and completely, by thoroughly working the sealant into the joint. Under-filling of joints normally leads to adhesion loss. After joints have been completely filled, they should be neatly tooled to eliminate air pockets or voids, and to provide a smooth, neat-appearing finish. Tooling also provides a slightly concave joint surface that improves the sealant configuration and achieves a visually satisfactory finish. Joint tooling should be performed within the allowable time limit for the particular sealant. The surface of the sealant should be a full, smooth bead, free of ridges, wrinkles, sags, air pockets, and embedded impurities.

Large daily temperature swings during curing (warm days, cold nights) may cause adhesive failure. A practical range of installation temperatures, considering moisture condensation or frost formation on joint edges at low temperatures and reduced working life at high temperatures, is from 40 to 80 °F (5 to 27 °C). This temperature range should be assumed in determining the anticipated amount of joint move-

ment in the design of joints. A warning note should be included on the plans that, if sealing must take place for any reason at temperatures above or below the specified range, a wider-than-specified joint may have to be formed. Alternately, changes in the type of sealant to one of greater movement capability or modifications to the depth-to-width ratio may be required to secure greater extensibility. The applicator should know the joint size limitation of the sealant selected.

When it is necessary to apply sealant below 40 °F (5 °C), steps must be taken to ensure clean, dry, frost-free surfaces. The area to be sealed should be wiped with a quick-drying solvent that is slightly water soluble, such as IPA, just before sealing. The area may be heated, if possible, or at least the sealant should be slightly warm (60 to 80 °F [15 to 27 °C]) when applied.

It is recommended that tools be used dry. Tooling solutions such as water, soaps, oil, or alcohols should not be used unless specifically approved by the sealant manufacturer as they may interfere with sealant cure and adhesion and create aesthetic issues.

It is imperative that uncured silicone or polyurethane sealants are not allowed to contact non-abradable surfaces such as polished stone, metal, or glass. These surfaces must be masked or extreme care taken to prevent any contact with the sealant during the application process. Excess sealant cannot be completely removed with organic or chlorinated solvents. Once an uncured sealant comes in contact with an exposed surface it will leave a film that may change the aesthetic or hydrophobic surface characteristics of the substrate.

Surfaces soiled with sealant materials should be cleaned as work progresses; removal is likely to be difficult after the sealant has cured. A solvent or cleaning agent recommended by the sealant manufacturer should be used.

Sealant Backing. For sealants to perform to their optimum movement parameters, they must adhere only to the joint sides and never to the base. Closed-cell expanded polyethylene, or non-gassing polyolefin sealant backing are the recommended backing materials for horizontal and vertical joints. For two-stage joints, open-cell polyurethane backing should be used on the interior seal unless the interior seal is allowed to cure for seven days before installing the exterior seal. Proper selection and use of backing material is essential for the satisfactory performance of watertight joints. When selecting a backing material and/or bond breaker, the recommendations of the sealant manufacturer should be followed to ensure compatibility with the sealant.

The principal functions of sealant backing materials are:

1. Controlling the depth and shape of the sealant in the joint (proper width to depth ratio). Also, profiles the rear surface to an efficient cross-section for resisting tensile forces.
2. Serving as a bondbreaker to prevent the sealant from adhering to the back of the joint. The sealant must adhere only to the two surfaces to which it bridges. If it also adheres to the back of the joint (three-sided adhesion), the stresses on the sealant bead are greatly increased and this increases the likelihood of premature sealant failure.
3. Assisting in tooling of the joint by providing back pressure when tooling. The combination of tooling and back pressure ensures full-sealant contact with the sides of the joint, which is vital if proper adhesion is to take place.
4. Protecting the back side of the sealant from attack by moisture vapors trying to escape from the building. Use of two-stage joints and backing is recommended where high vapor pressure occurs at the immediate back surface of the sealant.

The backing should not stain the sealant, as this may bleed through and cause discoloration of the joint. Sealant backing materials should be of suitable size and shape so that, after installation, they are compressed 25 to 50%. Compression differs with open- and closed-cell rods; refer to manufacturer's recommendations. Adequate compression is necessary so that the shape will stay in the opening and not be dislodged or moved by sealant installation.

Primers. Some sealants require primers on all substrates; others require primer for specific substrates or none at all. Absence of a required primer will cause premature sealant adhesion failure. A primer often helps sealant adhesion in cold weather. Primers are recommended by the sealant manufacturer for the following reasons:

1. To enhance adhesion of sealants to porous surfaces, such as concrete, or to reinforce the surface.
2. To promote adhesion of sealants to surfaces such as porcelain enamel, unusual types of glass, certain metals and finishes, and wood.
3. To promote adhesion of sealants to an existing surface treatment which is difficult to remove.

Special care should be exercised to avoid staining the visible face of the precast concrete unit because some primers leave an amber-colored stain if brushed along the surface. This stain will have to be mechanically removed, which will be expensive. The primer should be allowed to cure before application of the sealant. Sealant must be applied the same day the surfaces are primed. The sealant and primer should always be supplied by the same manufacturer.

4.7.8 Architectural Treatment

Joints should be expressed as a strong visual feature of architectural wall design. False joint lines can also add to the visual effect. Recessing

of joints and/or sealants will help diminish the visual impact of possible variations between adjacent surfaces sometimes inherent in large wall panels. Setting the sealant back from the face of the panel also gives some protection from UV light to minimize deterioration. By recessing the joints, the sideways flow of wind-driven rain over the sealant is reduced. Complicated edge and fenestration profiles should be avoided for economy in manufacturing and erection. Complicated profiles are more vulnerable to damage in handling and more difficult to make watertight.

Joints are important features in creating weathering patterns. Vertical joints help in channeling water, provided the joint is not pointed flush with a sealant or gasket. The concentration of water at such joints requires careful detailing to prevent moisture penetration.

Listed are detailing suggestions for typical architectural precast concrete panel joints (see Fig. 4.7.5, page 369).

1. Allow either a chamfered or reveal joint because these types of joints can accommodate the tolerances required for panel thickness, and the shadows formed within these joints will minimize any adverse effects on the aesthetic appearance of the joint system. By making the joints appear wider than they actually are, the visual differences in their width are proportionately reduced. This tends to make differences more difficult to detect and masks slight misalignments of the joints that might otherwise be especially noticeable at intersections. Simplifying the profile of the joints by providing a reasonable radius (chamfering) the panel edges assists in sealant installation and also has the obvious advantage of making the edges less vulnerable to chipping. Chips disrupt water flow and concentrate dirt.
2. Avoid the use of butt joints without a radiused or chamfered edge, as the tolerance variations in surface plane may result in the formation of unwanted shadow lines directly over the panels rather than within the joint area. This may impair the aesthetic appearance of the panel assembly.

Listed are detailing suggestions for staggering architectural precast concrete wall panels (Fig. 4.7.7).

1. Check for excessive thermal bowing of panels and set panel tolerances to avoid unwanted shadow lines at certain times of the day.
2. Consider joint configuration and joint tolerances to minimize unwanted shadow effects.
3. For loadbearing walls, there is a serious drawback to using horizontally staggered panels. If staggered panels are used, the floor slab must bear on two different panels on every other floor. The floor slab connection problem created should be avoided, if at all possible.

Finish requirements may also influence joint details. The sealant must be applied to a relatively smooth surface as it is difficult to tool the sealant to achieve intimate contact with an irregular surface. Thus, the sealant must be held back $\frac{1}{2}$ in. (13 mm) from the edge of exposed aggregate and that portion of the matrix along the joint should present a smooth, clean surface for the application of the sealant (see Section 5.2.1). This requirement is simple to comply with when the design includes recessed external joints (Fig. 4.7.5). When exposed aggregate surfaces come together at an inside corner, the situation is more difficult. Special attention must be paid to surface finish and joint details. Also, for maximum performance, sealants should not be applied to beveled or chamfered surfaces, but should be applied beyond the beveled area.

4.7.9 Fire-Protective Treatment

Joints between wall panels are similar to openings. Most building codes do not require openings to be protected against fire if the openings constitute only a small percentage of the wall area and if the spatial separation is greater than some code minimum distance. In such cases, the joints would not require protection. In other cases, openings, including joints, may have to be protected for fire resistance. Where no openings are permitted, the fire resistance required for the wall should be provided at the joints.

Fire tests of wall panel joints have shown that the fire endurance, as determined by a temperature rise of 325 °F (163 °C) over the unexposed joint, is influenced by joint type, joint treatment (materials), joint width, and panel thickness.

When required for fire rating, joints between wall panels should be detailed to prevent the passage of flames and hot gases. Details should ensure that the transmission of heat through the joints does not exceed the limits specified in ASTM E119 *Standard Methods of Fire Tests of Building Construction and Materials*. Concrete wall panels expand when heated, so the joints tend to close during fire exposure. By providing the proper thickness of insulating materials within the joint, it is possible to attain fire endurances essentially equal to those of the panels. Flexible, noncombustible materials, such as ceramic fiber blankets, provide thermal, flame, and smoke barriers. These fire resistive blankets and ropes must be installed with a minimum of 10 to 15% compression. When used in conjunction with caulking materials, they can provide the necessary fire protection and weathertightness while permitting normal volume change movements. Joints that do not require movement can be filled with mortar.

Figures 4.7.8 and 4.7.9 show the fire endurance of one-stage joints in which the joint treatment consisted of sealants and polyethylene backer rods.

Table 4.7.2 is based on results of fire tests of panels with one-stage joints and ceramic fiber felt in the joints. The tabulated values apply to

one-stage joints and are conservative for two-stage joints. Fire-resisting silicone sealants can provide fire ratings, if required. For high ratings, fire-retardant joint filler materials may also be required.

4.7.10 Joints in Special Locations

Below-grade joints between panels and the foundation require special attention. Good site drainage is essential for long-term waterproofing. A perforated drain tile should be placed below the top elevation of the floor slab. The top of the drain should be covered or encased with a filter fabric. The amount of coarse aggregate and its placement depend on soil type, amount of groundwater expected, and depth of the foundation. Where possible, slope the drain at least $\frac{1}{8}$ in./ft (3 mm/300 mm), and close off the end with wire mesh to keep rodents out. The discharge from drains should be carried away from the foundation.

Specifying the proper backfill density for compacted soil (between 85 and 88% on the Modified Proctor Density scale) is extremely important. Density above 88% can induce stress on the walls and impede drainage; density below 85% can result in some settlement.

The joint at the interface of the panel and foundation is typically grouted and the grout is raked out on the earth side and a backing material and sealant are installed. Due to large variations in cast-in-place concrete foundations, a minimum 1 in. (25 mm) joint is recommended at this interface. Damp-proofing materials may be used in the absence of hydrostatic pressure to resist the capillary action of moisture. Damp-proofing should be stopped below grade because, if exposed above a receding grade, it becomes a visible black line.

The amount of hydrostatic pressure expected in a building application also can be critical in material selection. For most buildings, hydrostatic pressure around the foundation is not a crucial factor, particularly if tile drains are installed and working properly.

However, a thorough analysis of groundwater levels and soil percolation rates surrounding the site should be made before deciding on the use of damp-proofing in lieu of waterproofing.

The joint between foundation panels should be caulked and then covered with a sheet waterproofing membrane, 20 to 120 mils (0.50 to 3 mm) thick. The entire foundation wall should then be covered with a sheet waterproofing membrane and an asphaltic protection board or grooved extruded polystyrene board with applied geotextile fabric.

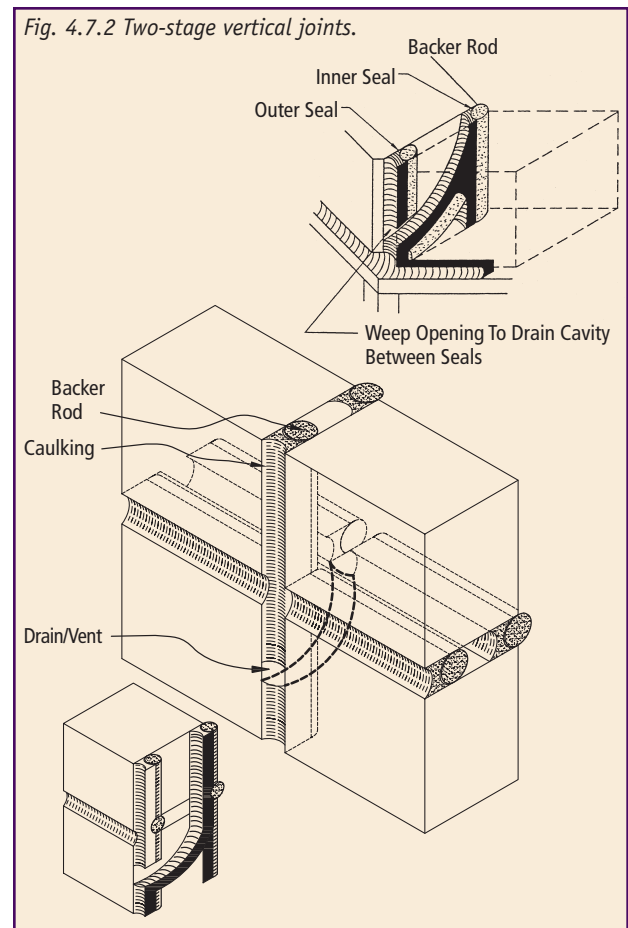
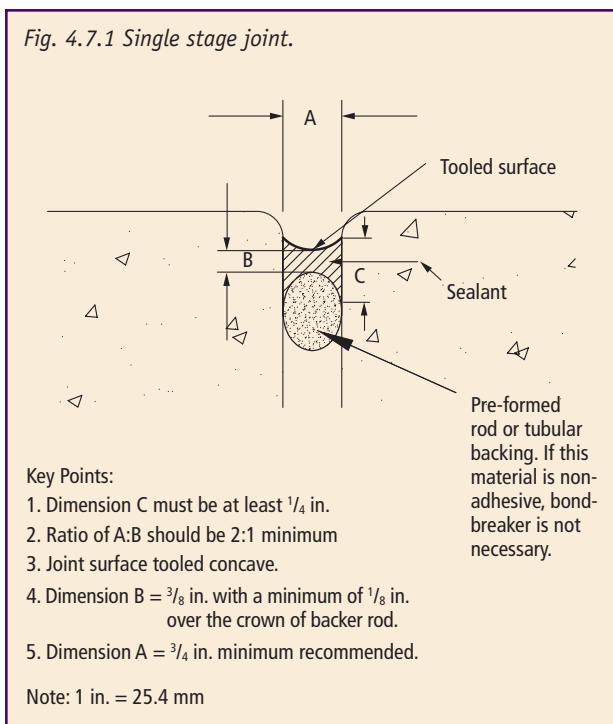
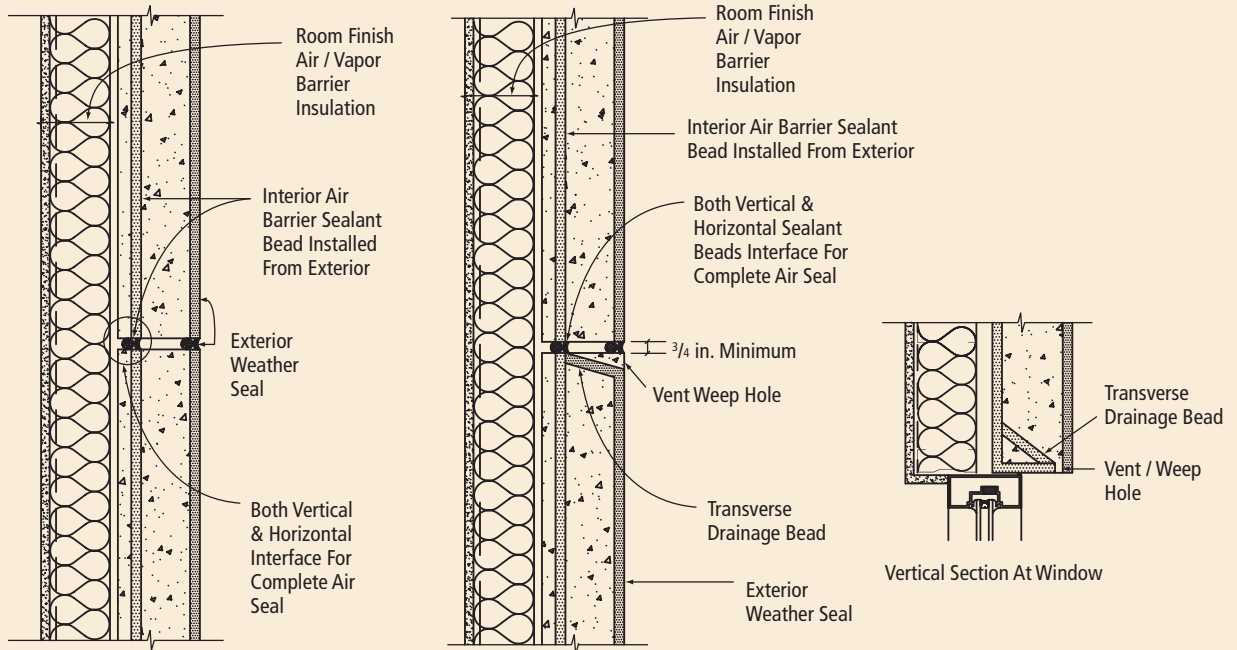
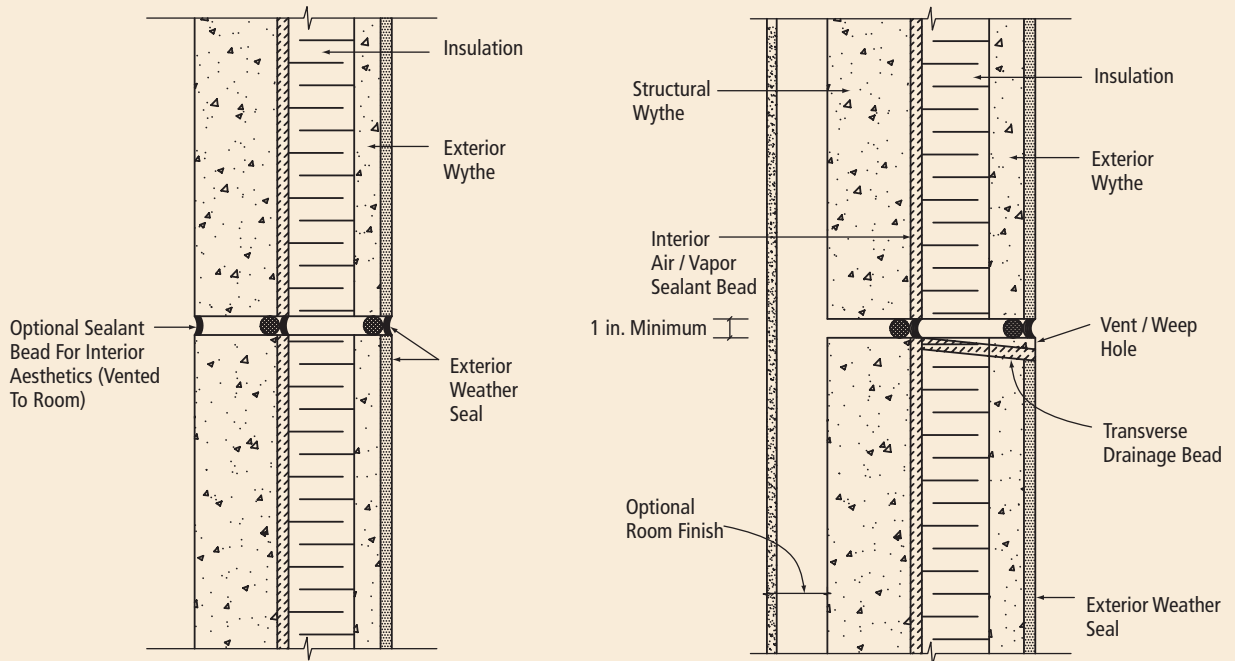

Fig. 4.7.3 Sealant and joint details.



Plan Section At Horizontal Joint

Vertical Section At Vertical Joint



Plan Section At Horizontal Joint

Vertical Section At Vertical Joint

Fig. 4.7.4 Expansion seal in vertical joint system.

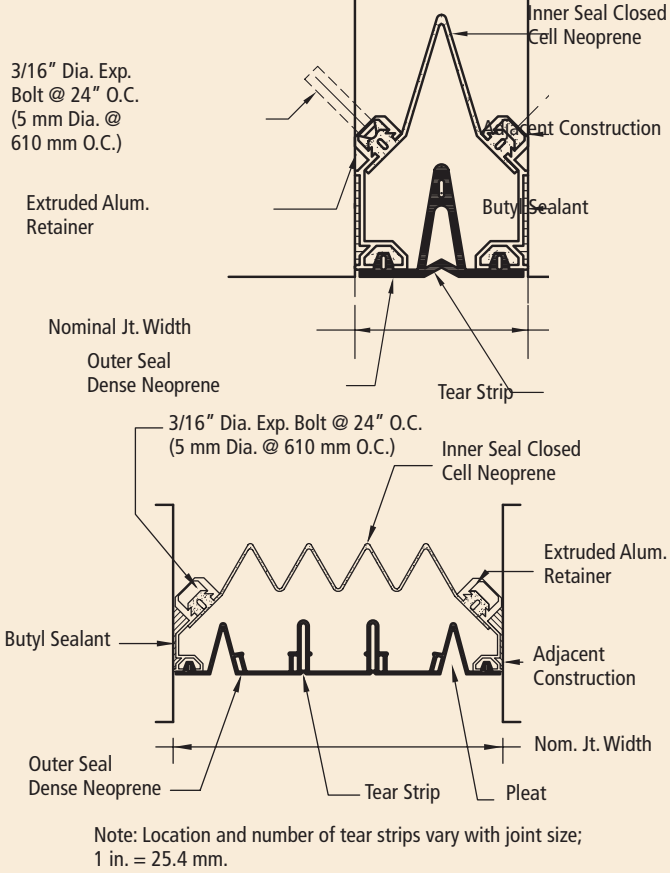

Fig. 4.7.7 Staggered architectural wall panels.

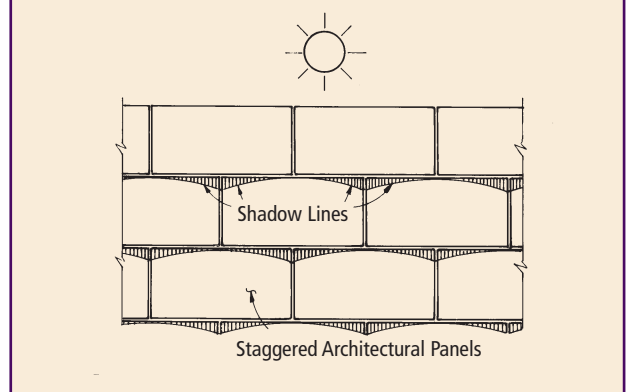

Fig. 4.7.5 Typical architectural panel joints.

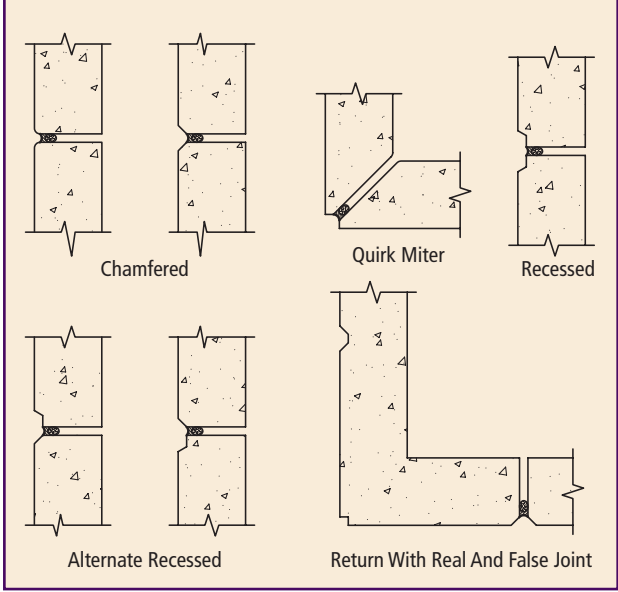

Fig. 4.7.6 Proper channeling of water.

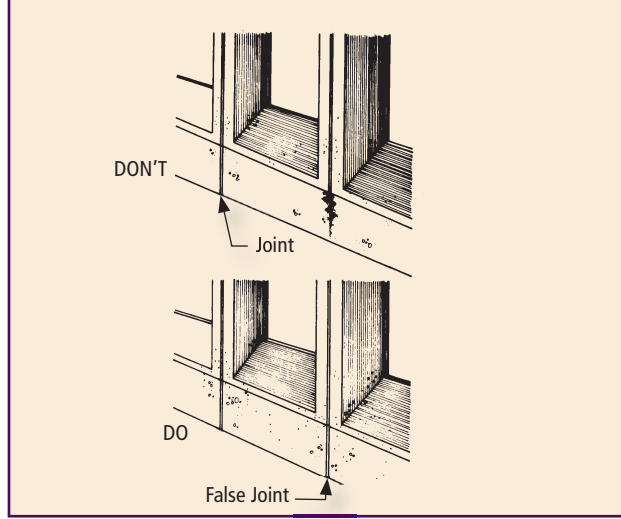

Table 4.7.1. Comparative Characteristics and Properties of Field-Molded Sealants.

	Polysulfides		Polyurethanes		Silicones	
	One-Component	Two-Component	One-Component	Two-Component	One-Component	Two-Component
Chief ingredients	Polysulfide polymers, activators, pigments, inert fillers, curing agents, nonvolatilizing plasticizers	Base: polysulfide polymers, activators, pigments, plasticizers, fillers Activator: accelerators, extenders, activators	Polyurethane prepolymer, filler pigments, plasticizers	Base: polyurethane prepolymer, filler pigments, plasticizers Activator: accelerators, extenders, activators	Siloxane polymer pigments: alcohol or other non-acid cure	Siloxane polymer pigments: alcohol or other non-acid cure
Primer required	Usually	Usually	Usually	Usually	Occasionally	Occasionally
Curing process	Chemical reaction with moisture in air and oxidation	Chemical reaction with curing agent	Chemical reaction with moisture in air	Chemical reaction with curing agent	Chemical reaction with moisture in air	Chemical reaction with curing agent
Tack-Free time, hr (ASTM C679)	24	36 – 48	24 – 36	24 – 72	1 – 2	½ – 5
Cure time, days ¹	7 – 14	7	7 – 14	3 – 5	7 – 14	4 – 7
Max. cured elongation (ASTM D412)	300%	600%	300%	500%	400 – 1600%	400 – 2000%
Recommended max. joint movement (ASTM C719)	± 25%	± 25%	± 15%	± 25%	± 25% to +100, - 50%	± 12½% to ± 50%
Max. joint width, in.	¾	1	1 ¼	2	3	3
Resistance to compression ²	Moderate	Moderate	High	High	Low	Low
Resistance to extension ²	Moderate	Moderate	Medium	Medium	Low	Low
Service temperature range, °F	- 40 to + 200	- 60 to + 200	- 40 to + 180	- 40 to + 180	- 60 to + 250	- 60 to + 250
Normal application temperature range, °F	+ 40 to + 120	+ 40 to + 120	+ 40 to + 120	+ 40 to + 120	- 20 to + 110	- 20 to + 110
Weather resistance	Good	Good	Very good	Very good	Excellent	Excellent
Ultra-Violet resistance, direct	Good	Good	Poor	Poor	Excellent	Excellent
Cut, tear, abrasion resistance	Good	Good	Excellent	Excellent	Good – excellent	Excellent – knotty tear
Life expectancy, years ³	20	20	10 – 20	10 – 20	20	20
Hardness, Shore A (ASTM C661)	25 – 35	25 – 45	25 – 45	25 – 45	15 – 35	15 – 40
Applicable specifications (Canadian)	FS: TT-S-00230C ASTM C920 (19-GP-13A)	FS: TT-S-00227E ASTM C290 (19-GP-24) (19-GP-3B)	FS: TT-S-00230C ASTM C920 (19-GP-13)	FS: TT-S-00227E ASTM C920 (19-GP-24)	FS: TT-S-00230C FS-TT-S-001543A ASTM C920 (19-GP-18)	FS: TT-S-00227E USASI A-116.1 ASTM C920 (19-GP-19)

¹ Cure time, as well as pot life, are greatly affected by temperature and humidity. Low temperatures and low humidity create longer pot life and cure time; conversely, high temperatures and low humidity create shorter pot life and cure time. Typical examples of variations are:

Two-Part Polysulfide			
Air temperature, °F	Pot life, hours	Initial cure, hours	Final cure, days
50	7-14	72	14
77	3-6	36	7
100	1-3	24	5

² Resistance to extension and compression is better known in technical terms as modulus, the unit stress required to produce a given strain. It is not constant but changes in values as the amount of elongation changes.

³ Life expectancy is directly related to joint design, workmanship, and conditions imposed on any sealant. The length of time illustrated is based on joint design within the limitations outlined by the manufacturer, and good workmanship based on accepted field practices and average job conditions. A violation of any one of the above would shorten the life expectancy to a degree. A total disregard for all would render any sealant useless within a very short period of time. Note: °F = °C (1.8) + 32; 1 in. = 25.4 mm.

Fig. 4.7.8 Fire endurance of one-stage joints.

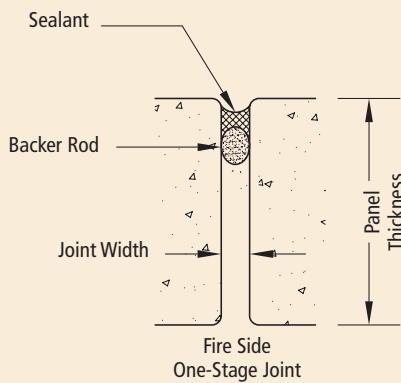
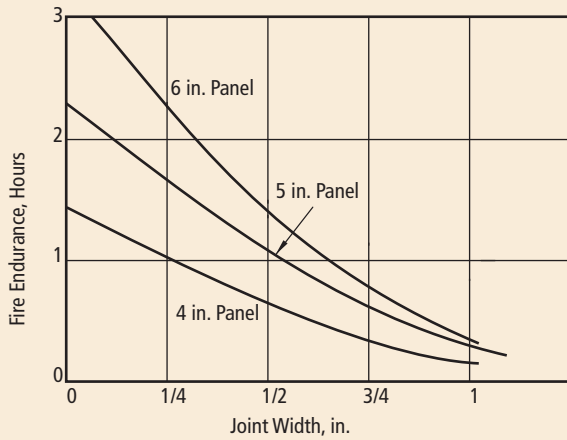

Fig. 4.7.9 Exterior joint sealing configurations and fire ratings (per UL 263).

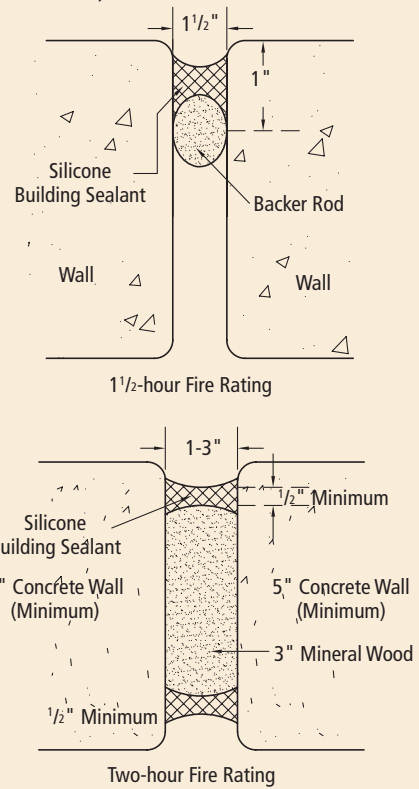

Table 4.7.2 Protection of joints between wall panels utilizing ceramic fiber felt.

Panel Thickness* (in.)	Thickness of ceramic fiber felt (in.) required for fire resistance ratings and joint widths shown							
	Joint width = 3/8 in.				Joint width = 1 in.			
	1 hr	2 hr	3 hr	4 hr	1 hr	2 hr	3 hr	4 hr
4	1/4	N.A.	N.A.	N.A.	3/4	N.A.	N.A.	N.A.
5	0	3/4	N.A.	N.A.	1/2	2 1/8	N.A.	N.A.
6	0	0	1 1/8	N.A.	1/4	1 1/4	3 1/2	N.A.
7	0	0	0	1	1/4	7/8	2	3 3/4

N.A. = Not applicable

* Panel equivalent thicknesses are for carbonate concrete. For siliceous aggregate concrete change "4, 5, 6, and 7" to "4.3, 5.3, 6.5, and 7.5". For sand-lightweight concrete change "4, 5, 6, and 7" to "3.3, 4.1, 4.9, and 5.7"

The tabulated values apply to one-stage joints and are conservative for two stage joints. Interpolation may be used for joint widths between 3/8 in. and 1 in.

Fig. 4.7.10

